

FRONT VIEW

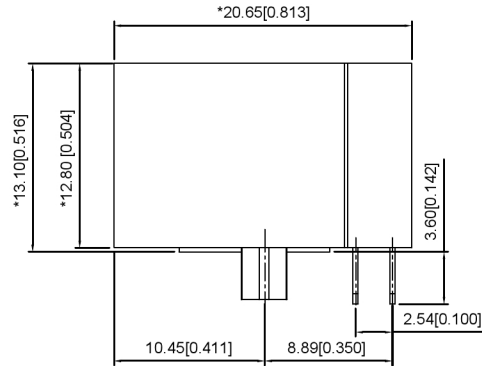

RIGHT SIDE VIEW

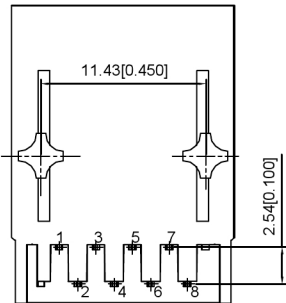

BOTTOM VIEW

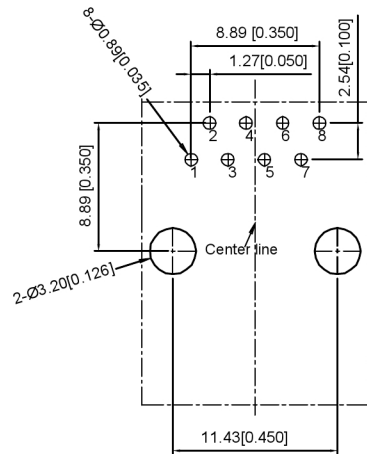

RECOMMENDED PCB LAYOUT VIEWED FROM COMPONENT SIDE

ELECTRICAL 电气:

1. Turn ratio 匝数比: 1~2: J1~J2=1CT:1CT(±2%)  
3~6: J3~J6=1CT:1CT(±2%)
2. OCL 已占搭载量: 350uH Min. at 100KHz 100mV 8mA DC.
3. Insertion Loss 插入损耗: -1.0 dB Max 1~100MHz
4. Return loss 回程损耗: -20dB Min 1~10MHz  
-16dB Min 10~30MHz  
-12dB Min 30~60MHz  
-10dB Min 60~80MHz
5. Cross talk 声道串扰: -40dB Min 1~30MHz;  
-35dB Min 30~60MHz;  
-30dB Min 60~100MHz;
6. CMR 共模抑制: -30dB Min 1~100MHz;
7. Hi-Pot 耐压测试: 1500V AC & 2250V DC 6S  
1mA PRI TO SEC

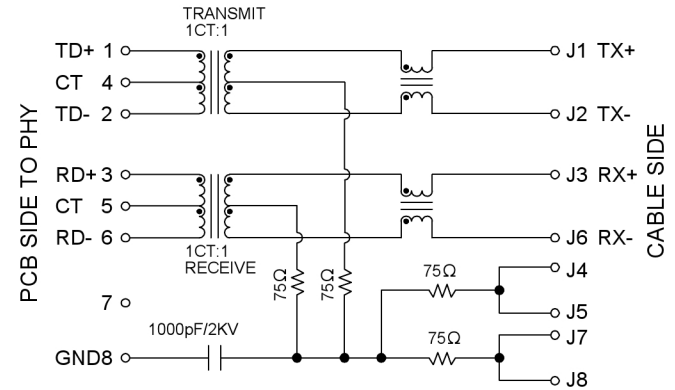

XKB Connectivity

MATERIAL 材料:

HOUSING 外壳: PBT, UL94V-0, BLACK.  
TERMINALS BRACKET 端子支架: PBT, UL94V-0, BLACK.  
TERMINAL 端子: PHOSPHOR BRONZE C5210, T=0.35MM,  
GOLD PLATING ON CONTACT AREA.

MECHANICAL 机械:

DURABILITY 耐用性: 750 CYCLES MIN.  
MATING FORCE 配合力: 23N MAX.  
OPERATING TEMPERATURE 工作温度: -40°C~+85°C.  
STORAGE TEMPERATURE 储存温度: -40°C~+85°C.  
ALL CRITICAL DIMENSIONS WITH "\*\*"

广东星坤科技股份有限公司

△X	日期
△X	
△X	
MARK	DESCRIPTION

文件工程章

					ANGULAR	±5°
					L ≤ 4	±0.2
					4 < L ≤ 16	±0.3
					16 < L ≤ 63	±0.4
					L > 63	±0.5
					UNSPECIFIED TOLERANCES	



DSND		SCALE: N/A	MODEL TYPE: RJ JACK
DWN		VIEW:	PART NO.:
CHKD		UNIT: mm/in	DWG NO.:
APPD		SIZE: A4	X01AB002IWAD
		WEIGHT	SHEET
		1/1	REVISIO A0

XKB INDUSTRIAL PRECISION CO., LIMITED