

LEFT SIDE VIEW

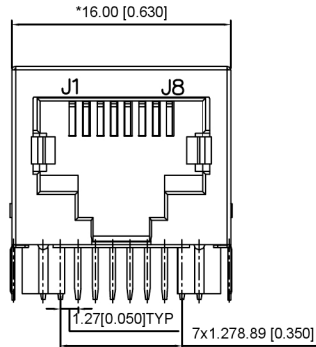

FRONT VIEW

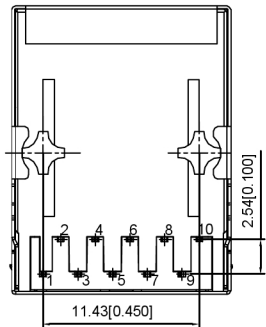

BOTTOM VIEW

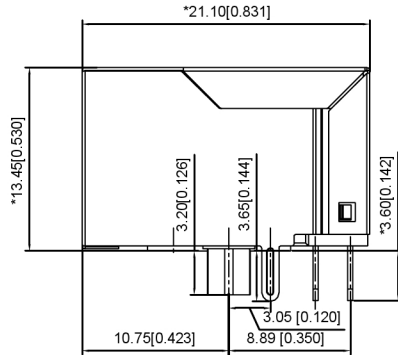

RIGHT SIDE VIEW

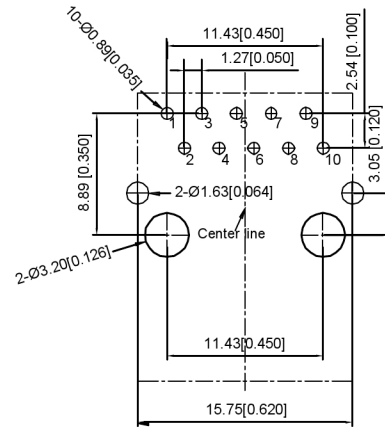

RECOMMENDED PCB LAYOUT  
VIEWED FROM COMPONENT SIDE

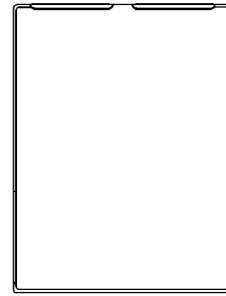

TOP VIEW

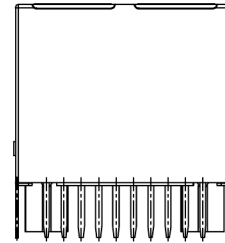

BACK VIEW

Electrical 电气:

- Turn ratio 匝数比: 2~3: J1~J2=1CT:1CT(±2%)  
4~7: J3~J6=1CT:1CT(±2%)  
5~6: J4~J5=1CT:1CT(±2%)  
8~9: J7~J8=1CT:1CT(±2%)
- OCL: 350uH Min. at 100KHz 100mV 8mA DC.
- Insertion Loss 插入损耗: -1.0 dB Max 1~100MHz.
- Return loss 回程损耗: -18dB Min 1~30MHz  
-14dB Min 30~60MHz  
-12dB Min 60~80MHz  
-10dB Min 80~100MHz
- Cross talk 声道串扰: -40dB Min 1~30MHz;  
-35dB Min 30~60MHz;  
-30dB Min 60~100MHz;
- CMR 共模抑制: -30dB Min 1~100MHz;
- Hi-Pot 耐压测试: 1500V AC & 2250V DC 6S  
1mA PRI TO SEC

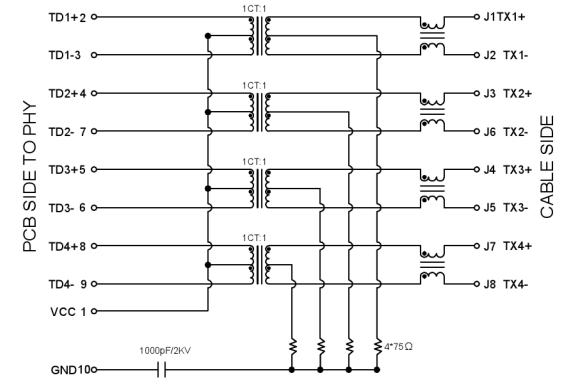

XKB Connectivity

MATERIAL 材料:

HOUSING 外壳: PBT, UL94V-0, BLACK, HF  
 TERMINALS BRACKET 端子支架: PBT, UL94V-0, BLACK, HF  
 SHIELD 保护物: C2680, T=0.20MM, NICKEL PLATING ON ALL AREA.  
 TERMINAL 端子: PHOSPHOR BRONZE C5210, T=0.35MM,  
 GOLD PLATING ON CONTACT AREA.

MECHANICAL 机械:

DURABILITY 耐用性: 750 CYCLES MIN.  
 MATING FORCE 配合力: 23N MAX.  
 OPERATING TEMPERATURE 工作温度: -40°C~+85°C.  
 STORAGE TEMPERATURE 储存温度: -40°C~+85°C.  
 ALL CRITICAL DIMENSIONS WITH "M"

广东星坤科技股份有限公司  
 文件工程章

MARK	DESCRIPTION	DATE	REVISED	APPROVED	UNSPECIFIED TOLERANCES
ΔX					ANGULAR ±5°
ΔX					L ≤ 4 ±0.2
ΔX					4 < L ≤ 16 ±0.3
					16 < L ≤ 63 ±0.4
					L > 63 ±0.5



DSND	SCALE: N/A	MODEL TYPE: RJ JACK
DWN	VIEW:	PART NO.:
CHKD	UNIT: mm/in	DWG NO.:
APPD	SIZE: A4	X01AQ066GWAD
	WEIGHT	SHEET 1/1
		REVISION A0

XKB INDUSTRIAL PRECISION CO., LIMITED