

FRONT VIEW

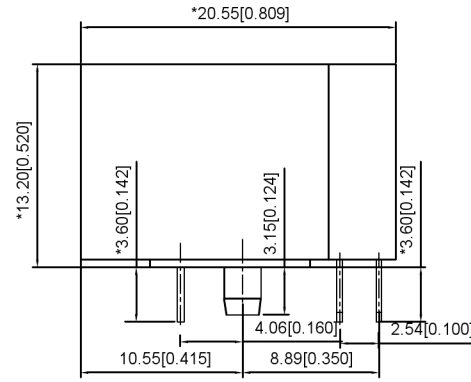

RIGHT SIDE VIEW

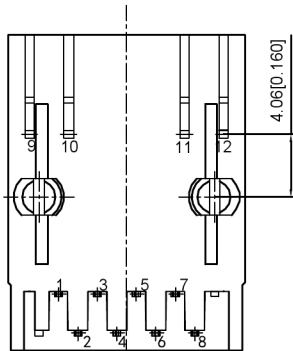

BOTTOM VIEW

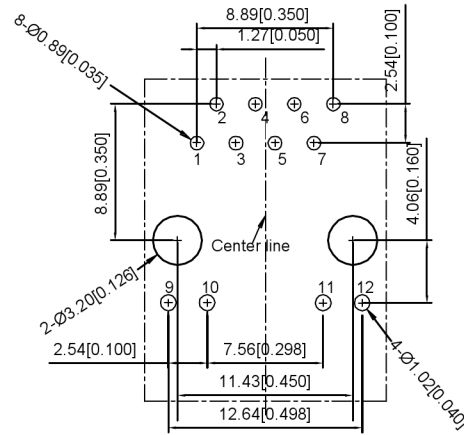

RECOMMENDED PCB LAYOUT
VIEWED FROM COMPONENT SIDE

ELECTRICAL 电气:

- Turn ratio 匝数比: 1~6: J1~J2=1CT:1CT(±2%)
4~6: J3~J6=1CT:1CT(±2%)
- OCL 已占搭载量: 350uH Min.at 100KHz 100mV 8mA DC.
- Insertion Loss 插入损耗: -1.0 dB Max 1~100MHz
- Return loss 回程损耗: -20dB Min 1~10MHz
-16dB Min 10~30MHz
-12dB Min 30~60MHz
-10dB Min 60~80MHz
- Cross talk 声道串扰: -40dB Min 1~30MHz;
-35dB Min 30~60MHz;
-30dB Min 60~100MHz;
- CMR 共模抑制: -35dB Min 1~100MHz;
- Hi-Pot 耐压测试: 1500V AC & 2250V DC 6S
1mA PRI TO SEC

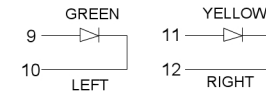
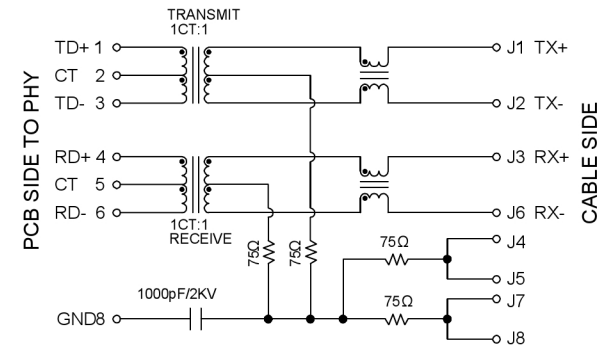

LED Specification

Standard LED Color	LED Wavelength	Forward(A)	Forward(V)
Green	568nm	20mA	1.85-2.45V
Yellow	585nm	20mA	1.7-2.2V

XKB Connectivity

MATERIAL 材料:

- HOUSING 外壳: PA9T,UL94V-0,YELLOW.
 TERMINALS BRACKET 端子支架: PBT,UL94V-0,BLACK.
 TERMINAL 端子: PHOSPHOR BRONZE C5210,T=0.35MM,
 GOLD PLATING ON CONTACT AREA.

MECHANICAL 机械:

- DURABILITY 耐用性: 750 CYCLES MIN.
 MATING FORCE 配合力: 23N MAX.
 OPERATING TEMPERATURE 工作温度: -40°C~+85°C.
 STORAGE TEMPERATURE 储存温度: -40°C~+85°C.
 ALL CRITICAL DIMENSIONS WITH ""

广东星坤科技股份有限公司

ΔX		日期
ΔX		日期
ΔX		日期
MARK	DESCRIPTION	

文件工程章

REVISIONS	DATE	REVISED	APPROVED	UNSPECIFIED TOLERANCES
ANGLAR			±5°	
L ≤ 4			±0.2	
4 < L ≤ 16			±0.3	
16 < L ≤ 63			±0.4	
L > 63			±0.5	

www.helloxkb.com www.helloxkb.cn www.xk-dg.cn



DSND		SCALE: N/A	MODEL TYPE: RJ JACK
DWN		VIEW:	PART NO.:
CHKD		UNIT: mm/in	DWG NO.:
APPD		SIZE: A4	X01AB083JB2UDB
XKB INDUSTRIAL PRECISION CO., LIMITED			WEIGHT
			SHEET
			REVISIO
			1/1
			A0