

LEFT SIDE VIEW

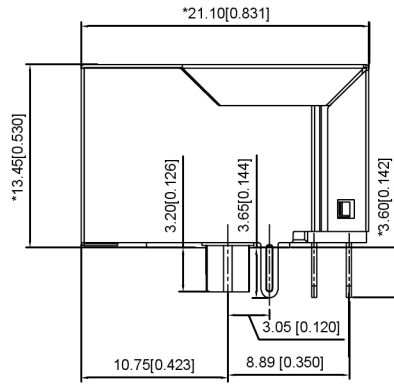

RIGHT SIDE VIEW

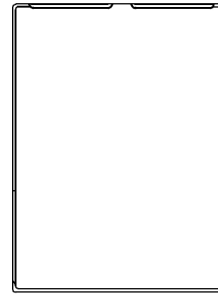

TOP VIEW

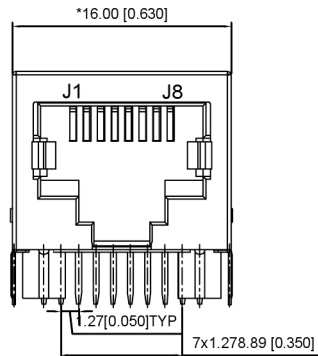

FRONT VIEW

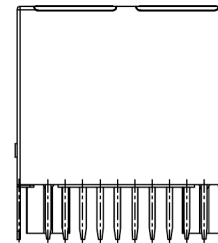

BACK VIEW

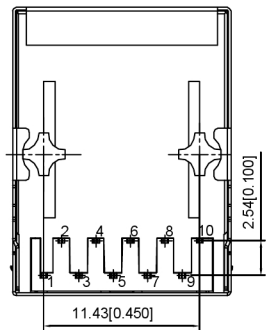

BOTTOM VIEW

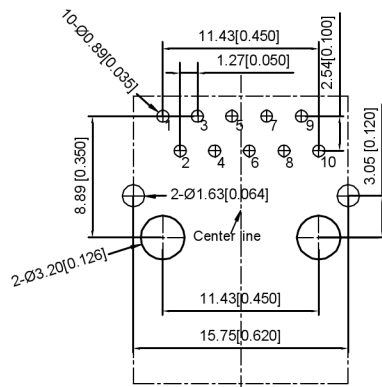

RECOMMENDED PCB LAYOUT VIEWED FROM COMPONENT SIDE

Electrical 电气:

- Turn ratio 匝数比: 1~2: J1~J2=1CT:1CT(±2%), 3~4: J3~J6=1CT:1CT(±2%), 7~8: J4~J5=1CT:1CT(±2%), 9~10: J7~J8=1CT:1CT(±2%)
- OCL: 180uH Min.at 100KHz 100mV
- Insertion Loss 插入损耗: -1.0 dB Max 1~125MHz
- Return loss 回程损耗: -20dB Min 1~40MHz, -20+15LOG10(f/40MHz) Min 40~200MHz
- Cross talk 声道串扰: -30dB Min 1~125MHz;
- CMR 共模抑制: -30dB Min 30~200MHz;
- Hi-Pot 耐压测试: 2250V DC 6S 1mA PRI TO SEC

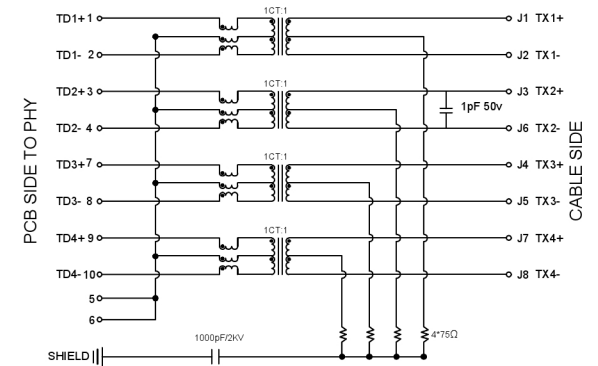

XKB Connectivity

MATERIAL 材料:

- HOUSING 外壳: PBT,UL94V-0,BLACK. HF
- TERMINALS BRACKET 端子支架: PBT,UL94V-0,BLACK. HF
- SHIELD 保护物: C2680,T=0.20MM,NICKEL PLATING ON ALL AREA.
- TERMINAL 端子: PHOSPHOR BRONZE C5210,T=0.35MM, GOLD PLATING ON CONTACT AREA.

MECHANICAL 机械:

- DURABILITY 耐用性: 750 CYCLES MIN.
- MATING FORCE 配合力: 23N MAX.
- OPERATING TEMPERATURE 工作温度: -40°C~+85°C.
- STORAGE TEMPERATURE 储存温度: -40°C~+85°C.
- ALL CRITICAL DIMENSIONS WITH ***



XKB INDUSTRIAL PRECISION CO.,LIMITED

DSND	SCALE: N/A	MODEL TYPE: RJ JACK
DWN	VIEW:	PART NO.:
CHKD	UNIT: mm/in	DWG NO.:
APPD	SIZE: A4	X01AQ285GWADA2
	WEIGHT	SHEET
		REVISION
	1/1	A0

广东星坤科技股份有限公司

ΔX	日期
ΔX	
ΔX	
MARK	DESCRIPTION

文件工程章

					ANGULAR	±5°
					L ≤ 4	±0.2
					4 < L ≤ 16	±0.3
					16 < L ≤ 63	±0.4
					L > 63	±0.5
					UNSPECIFIED TOLERANCES	
	REVISIONS	DATE	REVISED	APPROVED		
	www.helloxkb.com	www.helloxkb.cn	www.xk-dg.cn			