

| | | | |
|----------------|------------------|-------------------------|--------------------|
| 產品編碼 P/N | PDMCAT953-501MLN | 測試設備 TEST INSTRUMENT | Chroma: 3302 16502 |
| 產品系列 Series | 共模电感 | 測試頻率 TEST FREQUENCY | 1KHZ / 0.3V |

客戶名稱
Customer :

客戶編碼
Customer P/N :

產品系列
Series : 共模电感
Common Mode Line Chokes

產品編碼
Supply P/N : PDMCAT953-501MLN

發版號
Version : A2.1

承認日期
Endorsement Date : 2022-9-1

備註
Note :

| | |
|--|-------|
| 譜羅德電子科技（深圳）有限公司 PROD Electronic Technology (Shenzhen) Co. LTD | |
| 製作 APPROVED | Ben |
| 審查 CHECKED | Yuki |
| 確認 PREPARED | Peter |

客戶承認

Customer Approval

客戶簽章



| | | | |
|----------------|------------------|-------------------------|--------------------|
| 產品編碼 P/N | PDMCAT953-501MLN | 測試設備 TEST INSTRUMENT | Chroma: 3302 16502 |
| 產品系列 Series | 共模电感 | 測試頻率 TEST FREQUENCY | 1KHZ / 0.3V |

封裝尺寸 Dimension

(mm)

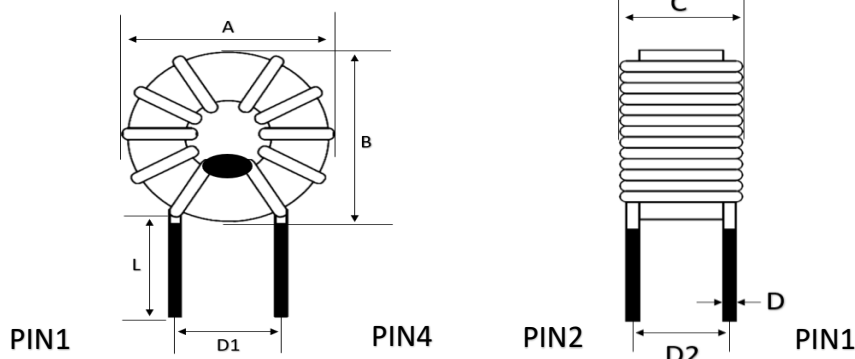

| 953 | 封裝尺寸 Dimension |
|------------|-------------------|
| A | 12 Max |
| B | 11 Max |
| C | 6 Max |
| D | 0.5 ±0.05 |
| D1 | 4.0 Ref |
| D2 | 4.5 Ref |
| L | 5.0 Min |
| MPQ | 300pcs/袋 |

編碼解釋

Code interpretation

| | | | | | |
|---------------|------------|------------|-----------|---------------|----------|
| PDMCAT | 953 | 501 | M | L | N |
| 類別碼 | 尺寸系列 | 感值 | 精度 | 立式 | 标准品 |
| Category code | Dimension | Inductance | Tolerance | Vertical type | Normal |

電氣參數

Electrical Characteristics

| 產品編碼 P/N | @ 25 °C Ambient Temperature | | | | | |
|------------------|-----------------------------|-----------|-----|---------------|---------------------|---------------------|
| | 感值 | 精度 | DCR | 額定電流 | 耐壓 | |
| | Inductance | Tolerance | | rated current | HI-POT | |
| | N1/N2 | N1/N2 | mΩ | mA | N1/N2 | N1~C/N2~C |
| | μH | Min (μH) | Max | ΔT ≈ 40°C | AC 600V | AC 600V |
| PDMCAT953-501MLN | 500 | 400 | 16 | 3000 | AC/60Hz 1mA 3Sec | AC/60Hz 1mA 3Sec |

- ◎ 規格參數基於環境溫度25°C取得
All test Data is referenced to 25°C ambient
- ◎ 電感工作環境溫度：-25°C ~ 105°C
Operating temperature range -25 °C to +105 °C
- ◎ 務必考慮最終的產品設計，元器件佈局，線路板走線，以及使用環境過程中，電感最終溫度不得超過105°C
The operating temperature of inductance do not exceed 85°C
- ◎ 參考產品開發設計實測尺寸，感值，DCR等數據，請參考規格書第5頁
The Dimension, Inductance, DCR test data is on page 5
- ◎ 使用電感時，請查閱第6頁注意事項
The announcements is on page 7

Page 3 / 7



| | | | |
|----------------|------------------|-------------------------|--------------------|
| 產品編碼 P/N | PDMCAT953-501MLN | 測試設備 TEST INSTRUMENT | Chroma: 3302 16502 |
| 產品系列 Series | 共模电感 | 測試頻率 TEST FREQUENCY | 1KHZ / 0.3V |

電感結構

Inductor Structure

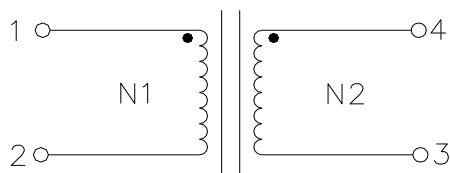

◎ 电感内置两组线圈

Inductor Contents Two (2) Set(s) of Coil

◎ 线径0.5mm 圈数: 10.5T 双线分绕

D: 0.5mm Turns: 10.5T

The two copper wires are wound separately

材料清單

Material List

| NO. | 材料 ITEM | 材質規格 Material | 製造商 Manufacturer | UL NO. |
|-----|------------|------------------|---------------------|--------|
| 1 | 磁芯/Core | T9*5*3 Mn-Zn | YUFENG (或等同廠商規格) | N.A |
| 2 | 漆包線/Wire | 2UEW+F 155°C | YIDA(或等同廠商規格) | N.A |
| 3 | 助焊剂/Flux | LD-007 | LEDA (或等同廠商規格) | N.A |
| 4 | 锡条/Sn | LEAD FREE SOLDER | CHENGNAN (或等同廠商規格) | N.A |

焊接溫度 (推荐)

Recommended Soldering Temperature Graph

TEMPERATURE (°C)

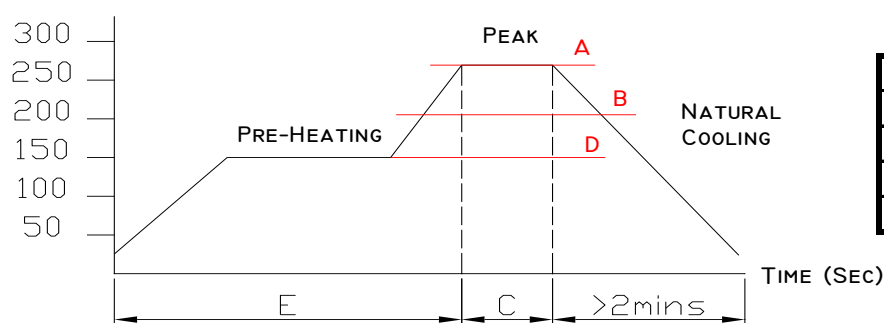

| | |
|---|------------|
| A | 260°C |
| B | 230°C |
| C | 10 Sec |
| D | 150°C |
| E | 60~240 Sec |



測試數據

TEST REPORT



| | | | |
|----------------|------------------|-------------------------|--------------------|
| 產品編碼 P/N | PDMCAT953-501MLN | 測試設備 TEST INSTRUMENT | Chroma: 3302 16502 |
| 產品系列 Series | 共模电感 | 測試頻率 TEST FREQUENCY | 1KHZ / 0.3V |

測試數據

Test Date

| 序号 | 尺寸測試數據 Dimension Test Date | | | | | | | 特性測試數據 Characteristics Test Date | | |
|-----|-------------------------------|--------|-------|-----------|---------|---------|---------|-------------------------------------|-------|-------|
| | A | B | C | D | D1 | D2 | L | DCR | Lo | Judge |
| | mm | mm | mm | mm | mm | mm | mm | mΩ | Min | |
| | 12 Max | 11 Max | 6 Max | 0.5 ±0.05 | 4.0 Ref | 4.5 Ref | 5.0 Min | 16 | 400 | |
| 1 | 10.69 | 9.47 | 4.36 | 0.51 | 4.03 | 4.52 | 8.81 | 12.08 | 582 | PASS |
| 2 | 10.66 | 9.44 | 4.43 | 0.51 | 3.91 | 4.59 | 8.28 | 12.14 | 734 | PASS |
| 3 | 10.62 | 9.52 | 4.35 | 0.50 | 3.98 | 4.52 | 8.34 | 12.05 | 625 | PASS |
| 4 | 10.71 | 9.43 | 4.42 | 0.50 | 3.95 | 4.53 | 8.15 | 12.18 | 588 | PASS |
| 5 | 10.65 | 9.47 | 4.38 | 0.49 | 4.02 | 4.49 | 8.25 | 12.11 | 684 | PASS |
| 6 | | | | | | | | | | PASS |
| 7 | | | | | | | | | | PASS |
| 8 | | | | | | | | | | PASS |
| 9 | | | | | | | | | | PASS |
| 10 | | | | | | | | | | PASS |
| 平均值 | 10.67 | 9.47 | 4.39 | 0.50 | 3.98 | 4.53 | 8.37 | 12.112 | 642.6 | |

◎ 所有测试数据基于环境温度25℃取得
All test Data is referenced to 25℃ ambient



譜羅德電子科技(深圳)有限公司
PULUODE Electronic Technology (Shenzhen) Co., LTD
深圳市寶安區石岩三聯工業區B棟311

更多规格请访问谱罗德官方网站
下载或者扫描二维码通过微信小程序
获取

<http://www.prodtech.cn/>





注意事項

使用本產品時，請注意以下事項

- ◎ 產品保存期限為12個月，保存條件：溫度5~40℃，濕度10~75%RH以內，超過保存期限可能會使產品端子電極發生氧化。
- ◎ 請勿在極端環境下使用和保存（高鹽，強酸，強鹼，強輻射等）。
- ◎ 產品焊接前，請進行預熱；預熱溫度與焊接溫度之間溫差建議控制在150℃以內。
- ◎ 產品焊接後需重新拆卸焊接修正時，請遵循規格書規定的條件範圍；過高的加熱溫度以及反復的拆卸可能會導致產品失效。
- ◎ 產品請勿接觸清洗劑，酒精等液體，這會侵蝕產品本體，從而導致產品失效。
- ◎ 產品焊接到線路板後，請注意不可因線路板整體變形或局部變形而施加給電感剩餘應力，這可能會導致電感發生破裂，脫落，以致失效。
- ◎ 產品通電後溫度會隨電流的增大而上升，設計時請務必考慮留有餘量。
- ◎ 過高的靜電會對產品產生永久性損害，請注意靜電防護。
- ◎ 產品通電過程請勿觸摸產品任何部位，防止觸電。
- ◎ 本產品作為磁性產品，設計時請務必考慮周邊元器件與本產品可能產生的相互影響。
- ◎ 本產品適用於一般電子設備，如：AV設備，通信設備，家電產品，娛樂設備，電腦設備，個人設備，辦公設備，計測設備，工業機器人等。且該一般電子設備需在常規的操作和使用方法環境下使用。對於需要高度安全性和可靠性的，或者因本產品失效造成設備故障，誤操作，運轉不良等危及到人的生命身體及財產安全，以及對社會產生較大不良影響的特殊用途，設計使用前務必同本公司溝通，設計使用者如未取得我司書面同意狀況下使用造成任何後果，我司不予承擔。特殊用途包含但不限定如下清單：
 - 1 軍用設備
 - 2 運輸設備（汽車，軌道交通產品，船舶等）
 - 3 航空，航太設備
 - 4 發電控制設備
 - 5 核動力相關設備
 - 6 爆炸引燃控制設備
 - 7 交通控制設備
 - 8 關係到國防安全的設備
 - 9 其他被認定為特殊用途的設備





ANNOUNCEMENTS

Please read this before using the product.

- © The product storage life is 12 months, Storage Temperature: TEMP.5~40°C; RH10%~75%. Please use the product within the warranty period
- © Do not use or store in locations where there are conditions such as gas corrosion (salt, acid, alkali, radiation etc.) .
- © Before soldering, be sure to preheat components:The preheating temperature should be set so that The temperature difference between the solder temperature and chip temperature does not exceed 150° C.
- © Soldering corrections after mounting should be within the range of the conditions determined in the specifications. If overheated, a short circuit, performance deterioration, or lifespan shortening may occur. Repeated disassembly may invalidate the inductance
- © The cleaning agent can not be used for these products. This may corrode the inductor
- © When embedding a printed circuit board where a chip is mounted to a set, be sure that residual stress is not given to the chip due to the overall distortion of the printed circuit board and partial distortion such as at screw tightening portions.
- © Self heating (Rated Current or Irms) occurs when the power is turned ON, so the tolerance should be sufficient for the set thermal design.
- © Too high static electricity will cause permanent damage to the product, please pay attention to electrostatic protection.
- © As a magnetic product, the design must consider the possible interaction between peripheral components and the product.

- © The products listed on this catalog are intended for use in general electronic equipment (AV equipment, telecommunications equipment, home appliances, amusement equipment, computer equipment, personal equipment, office equipment, measurement equipment, industrial robots) under a normal operation and use condition.

The products are not designed or warranted to meet the requirements of the applications listed below, whose performance and/or quality require a more stringent level of safety or reliability, or whose failure, malfunction or trouble could cause serious damage to society, person or property.

If you intend to use the products in the applications listed below or if you have special requirements exceeding the range or conditions set forth in the each catalog, please contact us. Otherwise, our

- | | |
|--|---|
| 1 Military equipment | 8 Medical equipment |
| 2 Transportation equipment (cars, trains, ships, etc.) | 9 Other applications that are not considered general-purpose applications |
| 3 Aerospace/aviation equipment | |
| 4 Power-generation control equipment | |
| 5 Atomic energy-related equipment | |
| 6 Explosive ignition control equipment | |
| 7 Transportation control equipment | |

