

RoHS

REV.	ECN NO.	REVISED	DATE

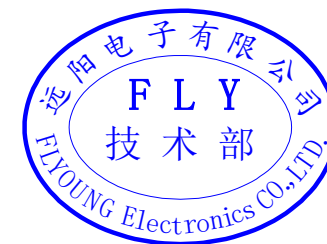
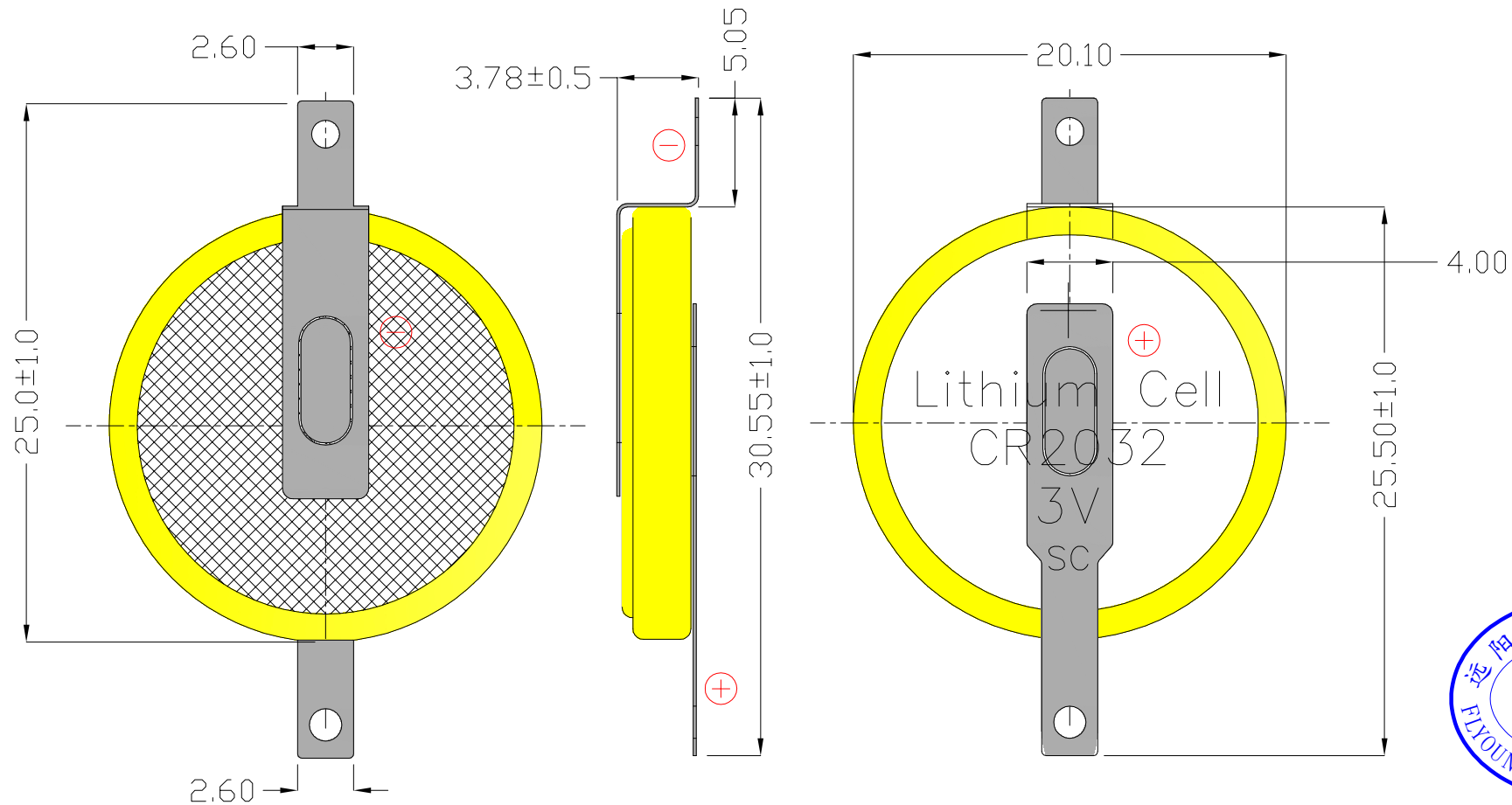

NO.	PART NAME	Q'TY	MATERIAL	PLATING & COLOR
2	TERMINAL(-)	1	STAINLESS STEEL T=0.15mm	Ni-Plating
1	TERMINAL(+)	1	STAINLESS STEEL T=0.15mm	Ni-Plating

UNLESS OTHERWISE SPECIFIED TOLERANCES		FLYOUNG 远阳 [®] ENERGY		www.flyoung-china.com	
DECIMALS: X :±1.00 X.X :±0.50 X.XX :±0.20 X.XXX :±0.10	ANGLES: X :±3° X.X :±1.5°	DSND	YangFeng	DATE	2022-08-30
WEIGHT:		CHKD	ZhouRuicai	DATE	2022-08-30
SHEET 1 OF 1		APVD	XueShunyong	DATE	2022-08-30
		SCALE:	SIZE: A4	VIEW:	⊙ ⊚
		UNIT: mm	REV.: A/1	OBJECT: FLY	DRAW NO.: FLY-HJ-002
		TITLE:		焊脚电池CR2032 3V 卧式	
		PART NO.:		CR2032-F-001	