

150KHz, 2A PWM BUCK DC/DC CONVERTER

Description

The HX1509 series are monolithic IC designed for a step-down DC/DC converter, and own the ability of driving a 2A load without additional transistor. It saves board space.

The external shutdown function can be controlled by logic level and then come into standby mode. The internal compensation makes feedback control having good line and load regulation without external design. Regarding protected function, thermal shutdown is to prevent over temperature operating from damage, and current limit is against over current operating of the output switch. If current limit function occurs and VFB is down below 0.5V, the switching frequency will be reduced. The HX1509 series operates at a switching frequency of 150KHz thus allow smaller sized filter components than what would be needed with lower frequency switching regulators. Other features include a guaranteed $\pm 4\%$ tolerance on output voltage under specified input voltage and output load conditions, and $\pm 15\%$ on the oscillator frequency. The output version included fixed 3.3V, 5V, 12V, and an adjustable type. The chips are available in a standard 8-lead SOP-8 package.

Features

- Output Voltage: 3.3V, 5V, 12V and Adjustable Output Version
- Adjustable Version Output Voltage Range, 1.23V to 18V+4%
- 150KHz +15% Fixed Switching Frequency
- Voltage Mode Non-Synchronous PWM Control
- Thermal-Shutdown and Current-Limit Protection
- ON/OFF Shutdown Control Input
- Operating Voltage can be up to 22V
- Output Load Current: 2A
- SOP-8L Packages
- Low Power Standby Mode
- Built-in Switching Transistor On Chip
- Available in "Green" Molding Compound (No Br, Sb)
- Lead Free Finish/ RoHS Compliant

Applications

- Simple High-Efficiency Step-Down Regulator
- On-Card Switching Regulators
- Positive to Negative Converter

Ordering Information

DEVICE	Package Type	MARKING	Packing	Packing Qty
HX1509D-3.3RG	SOP8	HX1509-3.3	REEL	2500pcs/Reel
HX1509D-5.0RG	SOP8	HX1509-5.0	REEL	2500pcs/Reel
HX1509D-12RG	SOP8	HX1509-12	REEL	2500pcs/Reel
HX1509D-ADJRG	SOP8	HX1509-ADJ	REEL	2500pcs/Reel

Pin Assignments

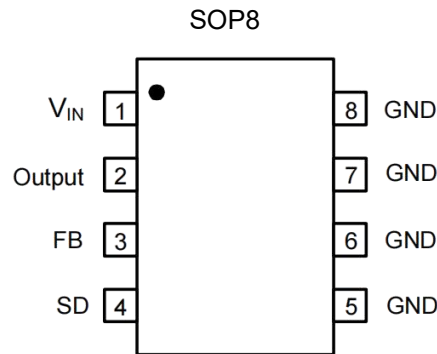

Typical Application Circuit

(1) Fixed Type Circuit

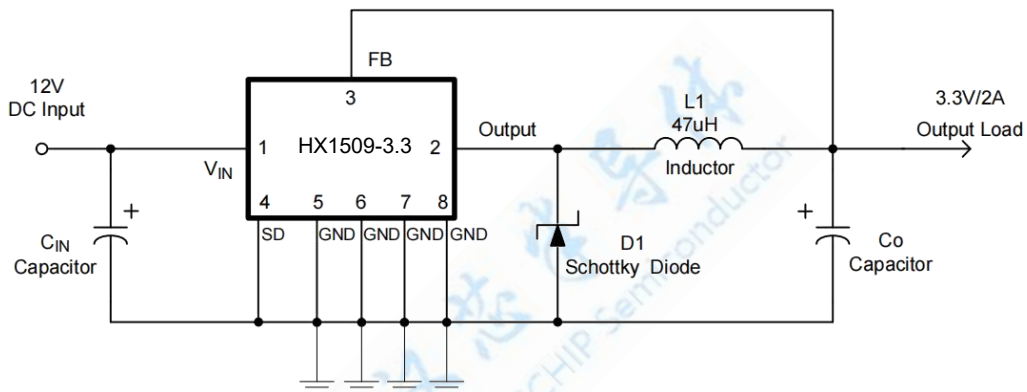

(2) Adjustable Type Circuit

(2) Adjustable Type Circuit

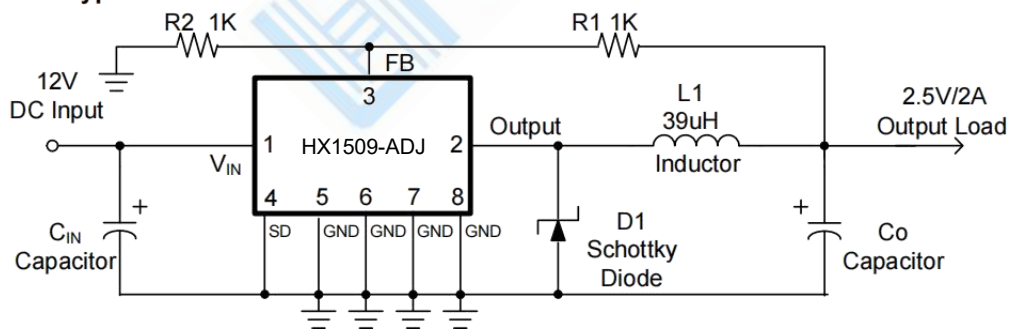

$$V_{OUT} = V_{FB} \times \left(1 + \frac{R1}{R2}\right)$$

$$V_{FB} = 1.23V$$

$$R2 = 1K \sim 3K$$

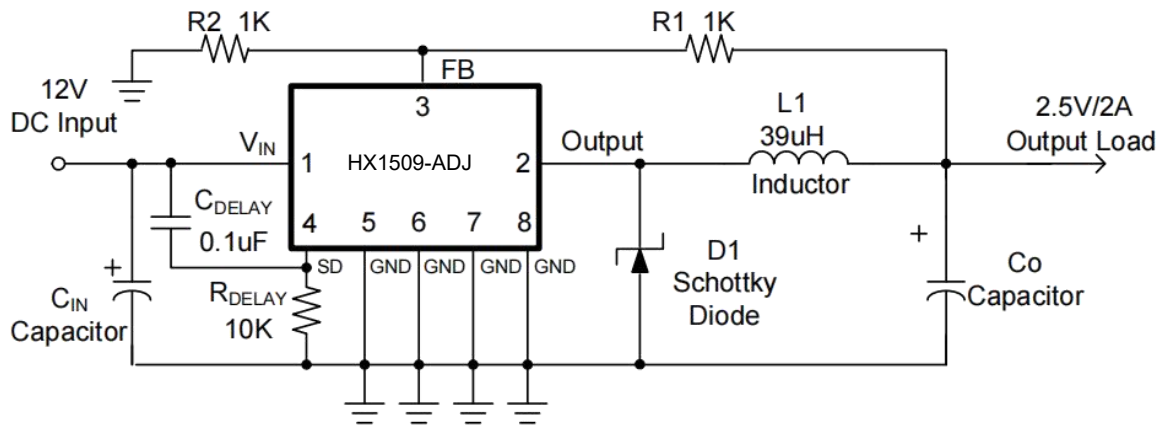
(3) Delay Start Circuit

Pin Descriptions

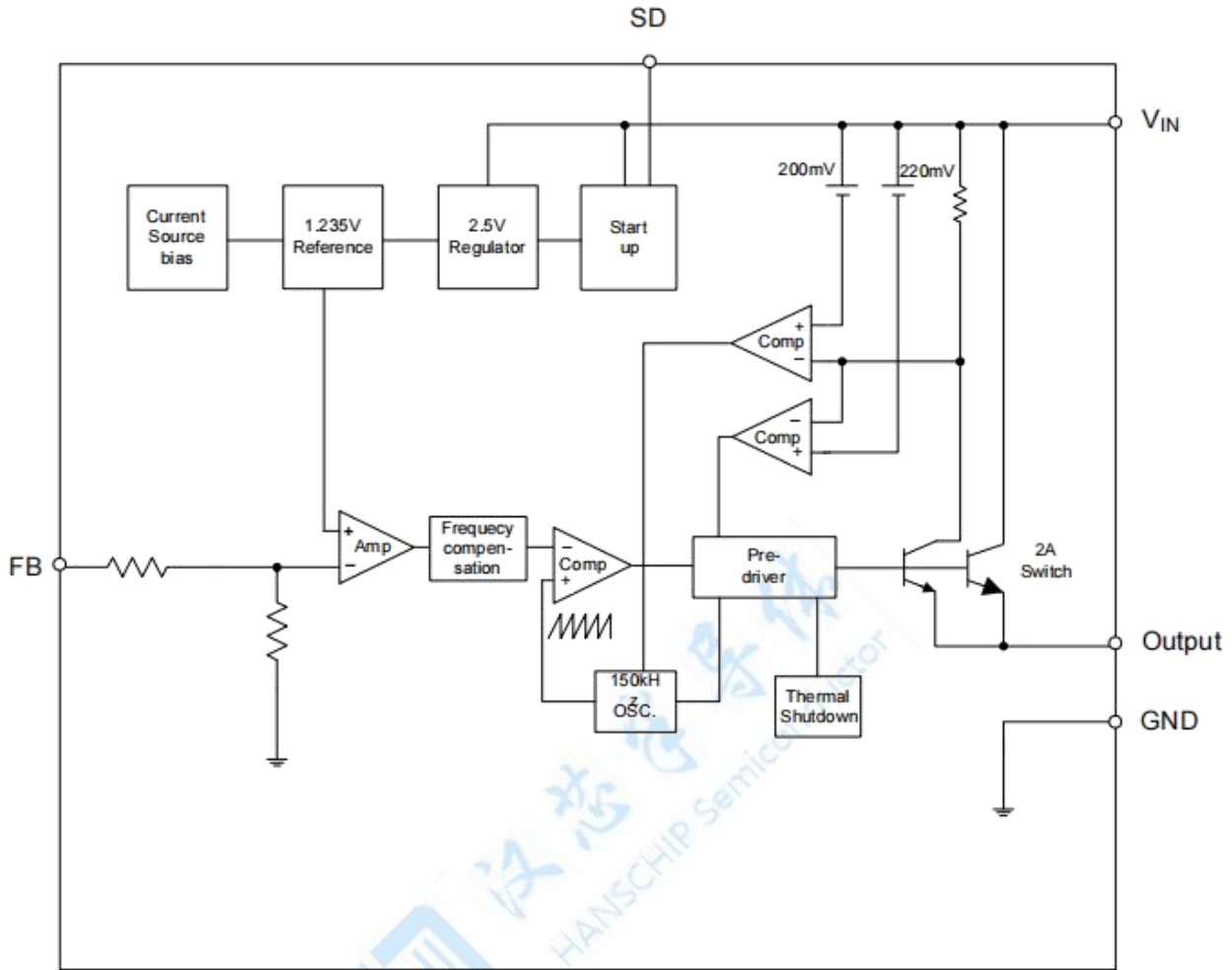
Pin Name	Description
V _{IN}	Operating voltage input
Output	Switching output
GND	Ground
FB	Output voltage feedback control
SD	ON/OFF Shutdown

Functional Block Diagram

Absolute Maximum Ratings

Symbol	Parameter	Rating	Unit
ESD HBM	Human Body Model ESD Protection	2	KV
ESD MM	Machine Model ESD Protection	200	V
V _{IN}	Supply Voltage	+24	V
V _{SD}	ON/OFF Pin Input Voltage	-0.3 to +18	V
V _{FB}	Feedback Pin Voltage	-0.3 to +18	V
V _{OUT}	Output Voltage to Ground	-1	V
P _D	Power Dissipation	Internally Limited	W
T _{ST}	Storage Temperature	-65 to +150	°C
T _J	Operating Junction Temperature	-40 to +125	°C

Recommended Operating Conditions

Symbol	Parameter	Min	Max	Unit
I _{OUT}	Output Current	0	2	A
V _{OP}	Operating Voltage	4.5	22	V
T _A	Operating Ambient Temperature	-20	85	°C

Electrical Characteristics

Unless otherwise specified, $V_{IN} = 12V$ for 3.3V, 5V, adjustable version and $V_{IN} = 18V$ for the 12V version. $I_{LOAD} = 0.5A$ Specifications with boldface type are for full operating temperature range, the other type are for $T_J = 25^\circ C$.

Symbol	Parameter		Conditions	Min	Typ.	Max	Unit
I _{FB}	Feedback Bias Current		$V_{FB} = 1.3V$ (Adjustable version only)		-10	-50 -100	nA
F _{OSC}	Oscillator Frequency			127 110	150	173 173	KHz
F _{SCP}	Oscillator Frequency of Short Circuit Protect		When current limit occurred and $V_{FB} < 0.5V$, $T_a = 25^\circ C$	10	30	50	KHz
V _{SAT}	Saturation Voltage		$I_{OUT} = 2A$ No outside circuit $V_{FB} = 0V$ force driver on		1.25	1.4 1.5	V
DC	Max. Duty Cycle (ON)		$V_{FB} = 0V$ force driver on		100		%
	Min. Duty Cycle (OFF)		$V_{FB} = 12V$ force driver off		0		
I _{CL}	Current Limit		Peak current No outside circuit $V_{FB} = 0V$ force driver on	3			A
I _L	Output = 0	Output Leakage	No outside circuit $V_{FB} = 12V$ force driver off			-200	uA
	Output = -1	Current	$V_{IN} = 22V$		-5		mA
I _Q	Quiescent Current		$V_{FB} = 12V$ force driver off		5	10	mA
I _{STBY}	Standby Quiescent Current		ON/OFF pin = $5V$, $V_{IN} = 22V$		70	150 200	uA
V _{IL}	ON/OFF Pin Logic Input		Low (regulator ON)	-	1.3	0.6	V
V _{IH}	Threshold Voltage		High (regulator OFF)	2.0		-	
I _H	ON/OFF Pin Logic Input Current		$V_{LOGIC} = 2.5V$ (OFF)			-0.01	uA
I _L	ON/OFF Pin Input Current		$V_{LOGIC} = 0.5V$ (ON)		-0.1	-1	
θ_{JA}	Thermal Resistance		SOP-8L Junction to case		15		$^\circ C/W$
θ_{JC}	Thermal Resistance with a copper area of approximately 3 in ²		SOP-8L Junction to ambient		70		$^\circ C/W$

Electrical Characteristics (Continued)

Specifications with boldface type are for full operating temperature range, the other type are for $T_J = 25^\circ C$.

	Symbol	Parameter	Conditions	V _{Min}	Typ.	V _{Max}	Unit
HX1509-ADJ	V _{FB}	Output Feedback	$4.5V \leq V_{IN} \leq 22V$ $0.2A \leq I_{LOAD} \leq 2A$ V_{OUT} programmed for 3V	1.193 1.18	1.23	1.267 1.28	V
		Efficiency	$V_{IN} = 12V$, $I_{LOAD} = 2A$	76	76		%
HX1509-3.3V	V _{OUT}	Output Voltage	$4.75V \leq V_{IN} \leq 22V$ $0.2A < I_{LOAD} < 2A$	3.168 3.135	3.3	3.432 3.465	V
		Efficiency	$V_{IN} = 12V$, $I_{LOAD} = 2A$	78	78		%
HX1509-5V	V _{OUT}	Output Voltage	$7V \leq V_{IN} \leq 22V$ $0.2A < I_{LOAD} < 2A$	4.8 4.75	5	5.2 5.25	V
		Efficiency	$V_{IN} = 12V$, $I_{LOAD} = 2A$	83	83		%
HX1509-12V	V _{OUT}	Output Voltage	$15V \leq V_{IN} \leq 22V$ $0.2A < I_{LOAD} < 2A$	11.52 11.4	12	12.48 12.6	V
		Efficiency	$V_{IN} = 15V$, $I_{LOAD} = 2A$	90	90		%

Typical Performance Characteristics

HX1509 Efficiency vs. Temperature
($V_{IN}=12V$, $V_{OUT}=5V$, $I_o=2A$)

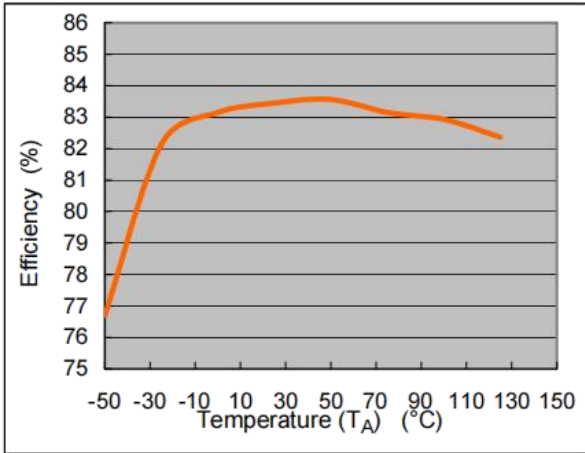

HX1509 Efficiency vs. Temperature
($V_{IN}=12V$, $V_{OUT}=3.3V$, $I_o=2A$)

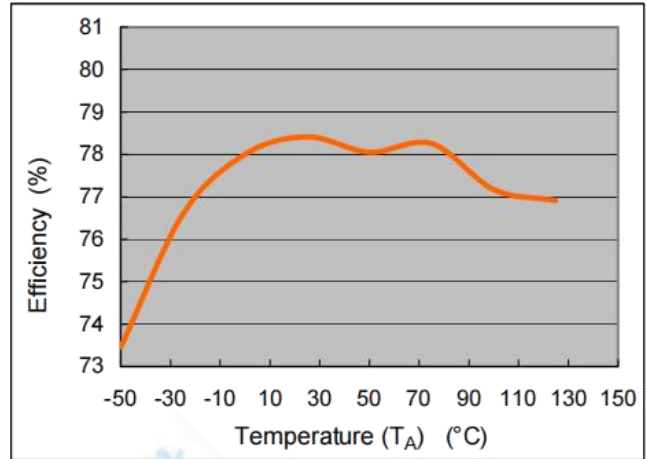

HX1509 Saturation Voltage vs. Temperature
($V_{IN}=12V$, $V_{FB}=0V$, $V_{SD}=0$)

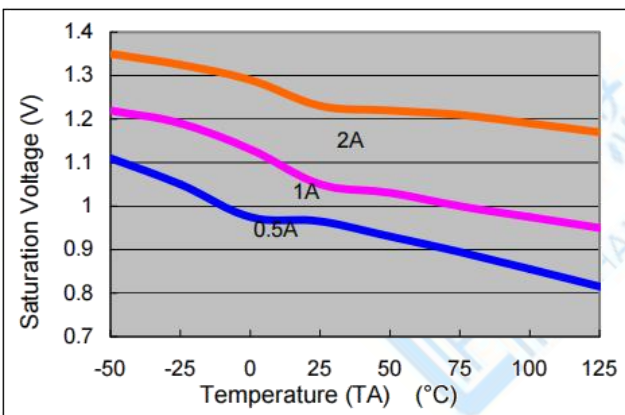

HX1509 Switch Current Limit vs. Temperature
($V_{IN}=12V$, $V_{FB}=0V$)

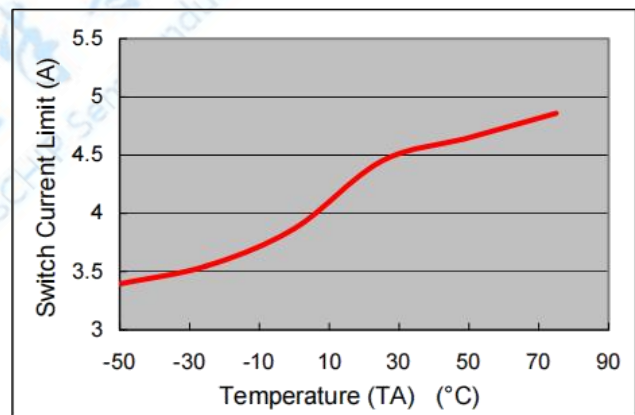

HX1509 Supply Current vs. Temperature

($V_{IN}=12V$, No Load, $V_{on/off}=0V$ (Switch ON), $V_{on/off}=5V$ (Switch OFF))

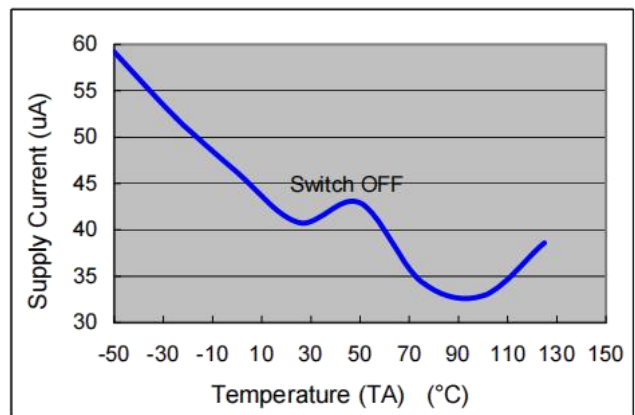
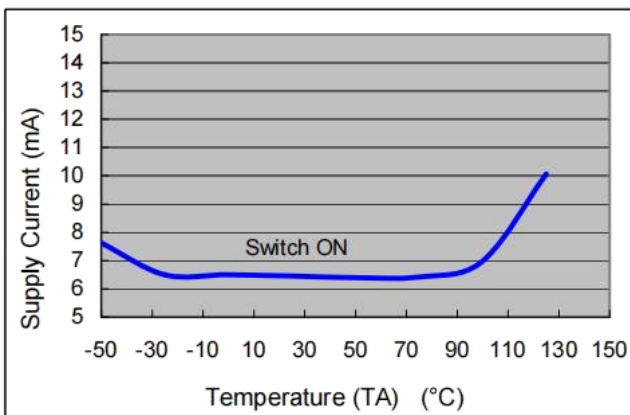

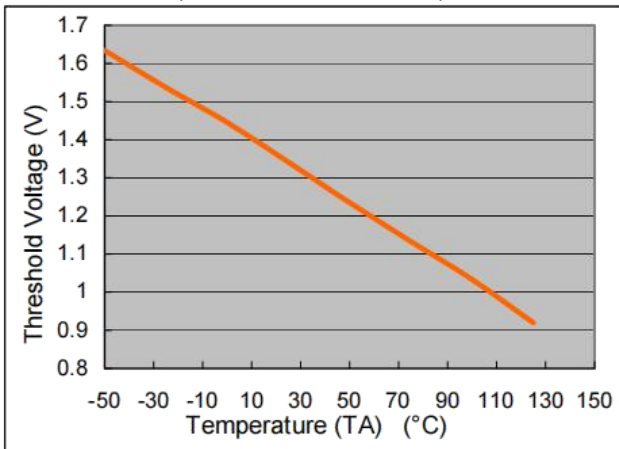
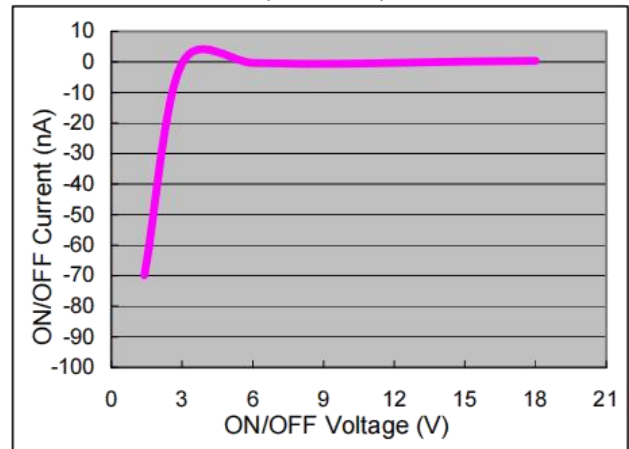
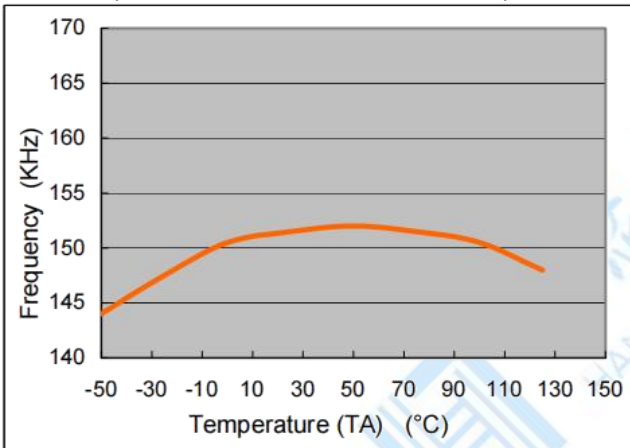
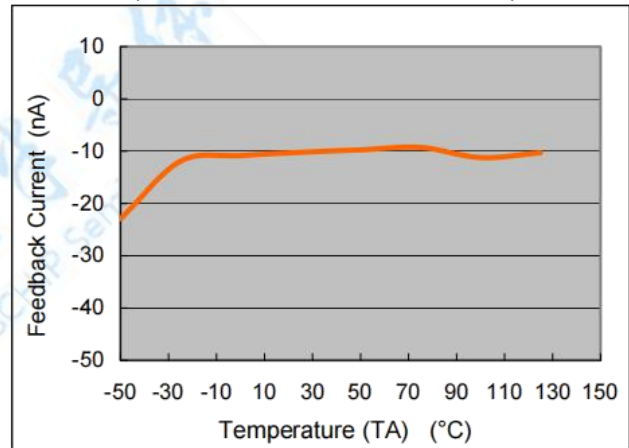
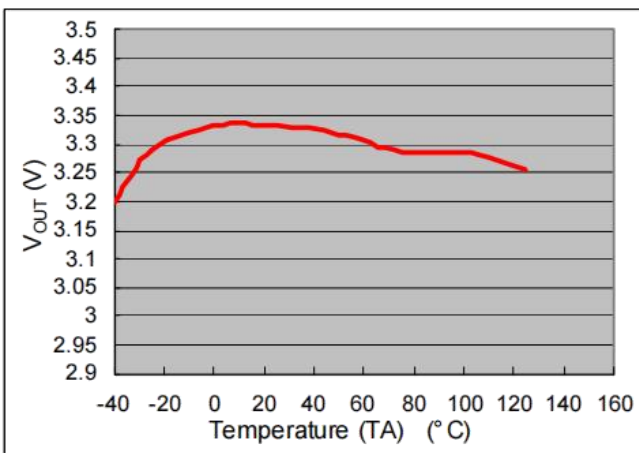
Typical Performance Characteristics (Continued)
HX1509 Threshold Voltage vs. Temperature
 ($V_{IN}=12V, I_o=100mA$)

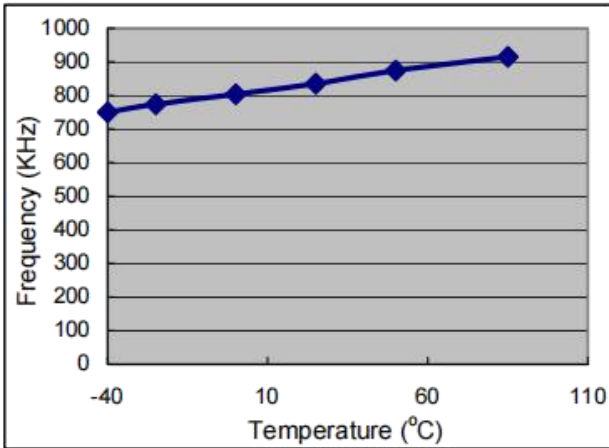
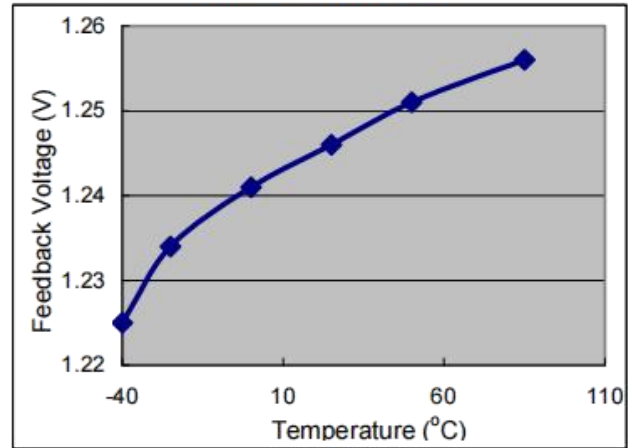
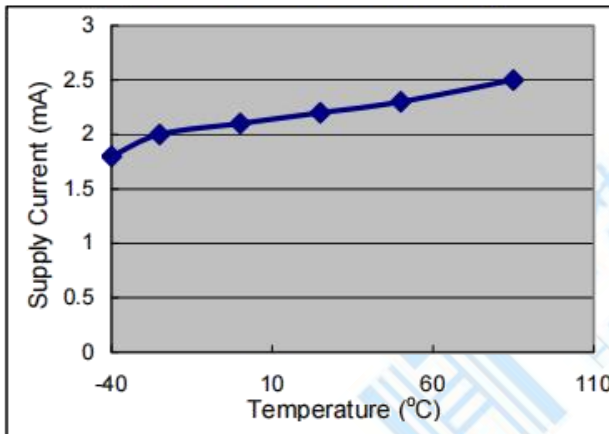
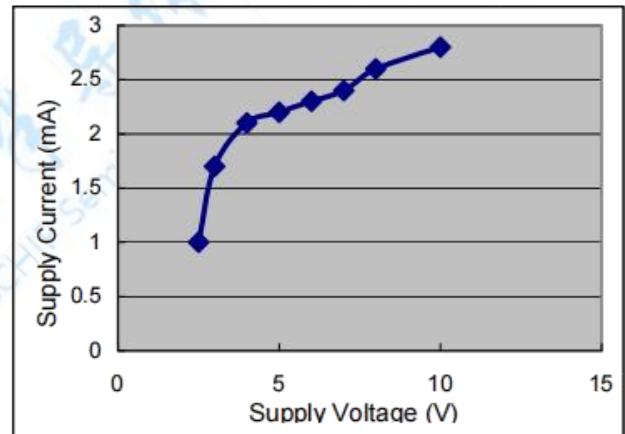
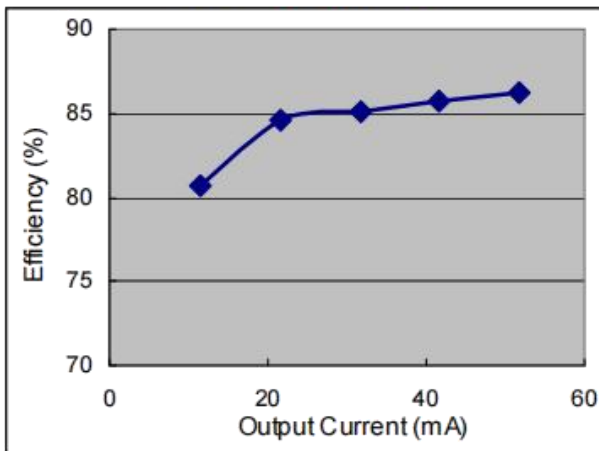
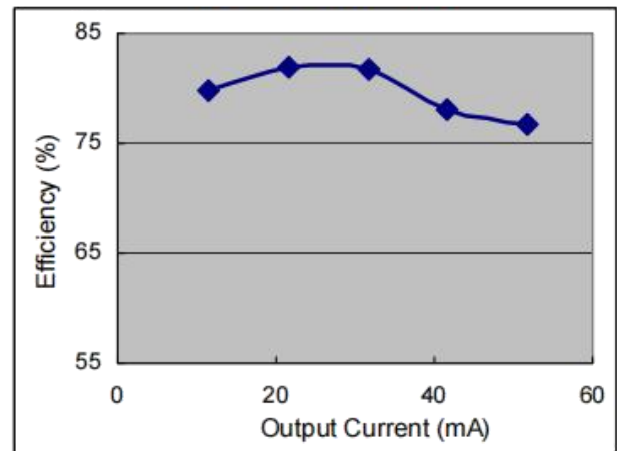
HX1509 ON/OFF Current vs. ON/OFF Voltage
 ($V_{IN}=12V$)

HX1509 Frequency vs. Temperature
 ($V_{IN}=12V, I_o=500mA, V_{OUT}=5V$)

HX1509 Feedback Current vs. Temperature
 ($V_{IN}=12V, V_{OUT}=5V, V_{fb}=1.3V$)

HX1509 Output Voltage vs. Temperature
 ($V_{IN}=12V, I_o=2A$)

Typical Performance Characteristics (Continued)
Header Frequency vs. Temperature

Feedback Voltage vs. Temperature
 $(V_{IN}=15V, V_{OUT}=5V)$

Supply Current vs. Temperature
 $(V_{IN}=15V, V_{OUT}=5V, I_{OUT}=0A)$

Supply Current vs. Supply Voltage
 $(V_{IN}=15V, V_{OUT}=5V, I_{OUT}=0A)$

Efficiency vs. Output Current
 $(V_{IN}=15V, V_{OUT}=5V)$

Efficiency vs. Output Current
 $(V_{IN}=15V, V_{OUT}=3.3V)$

Functions Description

Pin Functions

+V_{IN}

This is the positive input supply for the IC switching regulator. A suitable input bypass capacitor must be presented at this pin to minimize voltage transients and to supply the switching currents needed by the regulator.

Ground

Circuit ground.

Output

Internal switch. The voltage at this pin switches between (+V_{IN} – V_{SAT}) and approximately – 0.5V, with a duty cycle of approximately V_{OUT} / V_{IN}. To minimize coupling to sensitive circuitry, the PC board copper area connected to this pin should be minimized.

Feedback

Senses the regulated output voltage to complete the feedback loop.

SD

Allows the switching regulator circuit to be shutdown using logic level signals thus dropping the total input supply current to approximately 150uA. Pulling this pin below a threshold voltage of approximately 1.3V turns the regulator on, and pulling this pin above 1.3V (up to a maximum of 18V) shuts the regulator down. If this shutdown feature is not needed, the SD pin can be wired to the ground pin.

Thermal Considerations

The SOP-8L package needs a heat sink under most conditions. The size of the heat sink depends on the input voltage, the output voltage, the load current and the ambient temperature. The HX1509 junction temperature rises above ambient temperature for a 2A load and different input and output voltages. The data for these curves was taken with the HX1509 (SOP-8L package) operating as a buck-switching regulator in an ambient temperature of 25o C (still air). These temperature increments are all approximate and are affected by many factors. Higher ambient temperatures require more heat sinker.

For the best thermal performance, wide copper traces and generous amounts of printed circuit board copper should be used in the board layout (One exception is the output (switch) pin, which should not have large areas of copper). Large areas of copper provide the best transfer of heat (lower thermal resistance) to the surrounding air, and moving air lowers the thermal resistance even further.

Package thermal resistance and junction temperature increments are all approximate. The increments are affected by a lot of factors. Some of these factors include board size, shape, thickness, position, location, and even board temperature. Other factors are, trace width, total printed circuit copper area, copper thickness, single or double-sided, multi-layer board and the amount of solder on the board.

The effectiveness of the PC board to dissipate heat also depends on the size, quantity and spacing of other components on the board, as well as whether the surrounding air is still or moving. Furthermore, some of these components such as the catch diode will add heat to the PC board and the heat can vary as the input voltage changes. For the inductor, depending on the physical size, type of core material and the DC resistance, it could either act as a heat sink taking heat away from the board, or it could add heat to the board.

Physical Dimensions

SOP8 (150mil)

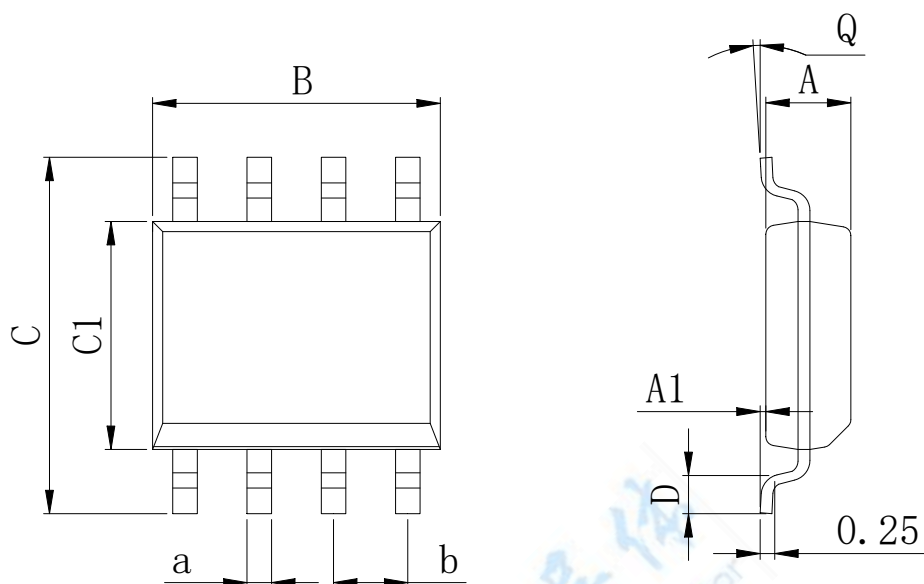

Dimensions In Millimeters(SOP8)									
Symbol:	A	A1	B	C	C1	D	Q	a	b
Min:	1.35	0.05	4.90	5.80	3.80	0.40	0°	0.35	1.27 BSC
Max:	1.55	0.20	5.10	6.20	4.00	0.80	8°	0.45	

IMPORTANT STATEMENT:

Shenzhen Hanschip semiconductor co.,ltd. reserves the right to change the products and services provided without notice. Customers should obtain the latest relevant information before ordering, and verify the timeliness and accuracy of this information.

Customers are responsible for complying with safety standards and taking safety measures when using our products for system design and machine manufacturing to avoid potential risks that may result in personal injury or property damage.

Our products are not licensed for applications in life support, military, aerospace, etc., so we do not bear the consequences of the application of these products in these fields.

Our documentation is only permitted to be copied without any tampering with the content, so we do not accept any responsibility or liability for the altered documents.

