

1	2	3	4	5	6
Rating	Electrical Life	100,000 cycles	100,000 cycles	100,000 cycles	100,000 cycles
Contact Resistance	Mechanical Life	100,000 cycles	100,000 cycles	100,000 cycles	100,000 cycles
Insulation Resistance	Ambient Temper. Used	-25 to +85	-25 to +85	-25 to +85	-25 to +85
Withstand Voltage	Ambient Humidity Used	≤85% at +40	≤85% at +40	≤85% at +40	≤85% at +40
Soldering Temper.	Operating Force	30 ±15gf max	30 ±15gf max	30 ±15gf max	30 ±15gf max

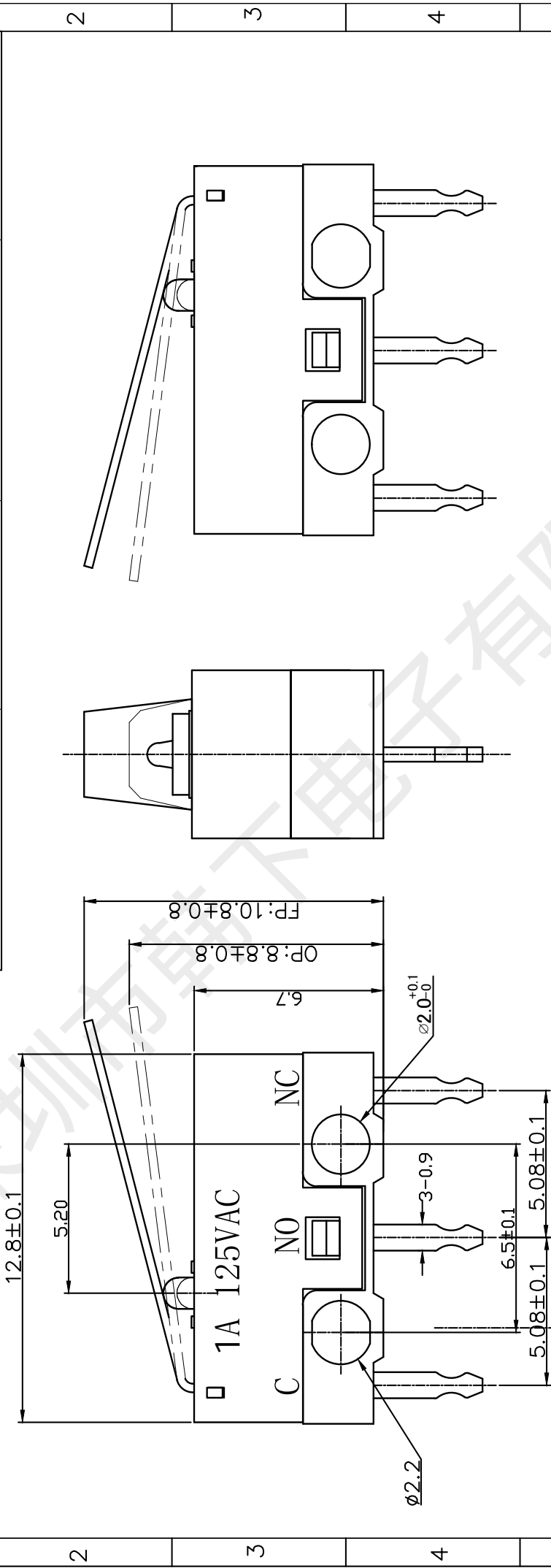

6	触点	1	银镍合金	数量	备注
5	按钮	1	PBT 阻燃料		
4	压柄	1	SUS301		
3	弹片	1	CT7200		
2	盖片	1	PBT 阻燃料		
1	底座	1	PBT 阻燃料		
序号	零件名称	数量	材质		备注

制图		李春风	审核		钟华	比例		4:1	名称		微动开关
设计			检查		罗孝金	张数		1/1	料号		
批准			批准			单位		mm	模具编号		HX DM1-03P-30-3 1A
一般公差			公差			角度		±2.0°	纸张		A4
TOLERANCE			公差			公差		±0.10	尺寸		SIZE
APPROVE			公差			公差		±0.05	角法		PROJ.
修改			修改			公差		±0.15	工程图		ENG DRAW
DRAW			DRAW			公差		±0.20	工程图		ENG DRAW
变更内容			变更内容			公差		±0.10	工程图		ENG DRAW
DEFINITION			DEFINITION			公差		±0.05	工程图		ENG DRAW
日期			日期			公差		±0.15	工程图		ENG DRAW
DATE			DATE			公差		±0.20	工程图		ENG DRAW
ECN 编号			ECN 编号			公差		±0.10	工程图		ENG DRAW
ECN NO.			ECN NO.			公差		±0.05	工程图		ENG DRAW

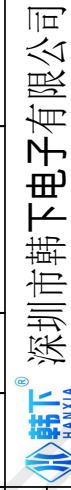



深圳市韩下电子有限公司

Shenzhen Hanxia Electronic Co., Ltd  
Tel: 0755-33819206 Fax: 0755-27597491

**承 认 书**  
**SPECIFICATION FOR APPROVAL**

客 户 Customer: \_\_\_\_\_

产品名称 Project: 微动开关  
\_\_\_\_\_

规格型号 Part No: HX DM1-03P-30-3 1A  
\_\_\_\_\_

**贵公司承认印 Approval signatures**

料 号/Part No.	签 章/Signatures

日期 Date:

拟制/Drawn	李春风	
审核/Check	钟华华	
批准/Approved	罗孝金	

## 规 格 书

### SPECIFICATION

#### 1. 一般特性 General Characteristics

- 1.1 额定值(Rating Value): AC 125V 1A
- 1.2 工作温度(Work Temperature Range):  $-25^{\circ}\text{C} \sim 85^{\circ}\text{C}$
- 1.3 存贮温度(Store Temperature Range):  $-20^{\circ}\text{C} \sim 80^{\circ}\text{C}$
- 1.4 正常测试条件(未有特殊说明量测在以下条件进行):

General test condition (Tests and measurements shall be made under the following standard conditions unless otherwise specified):

正常温度:  $5^{\circ}\text{C} \sim 35^{\circ}\text{C}$       相对湿度: 45%~85% RH      气压: 8,600~10,600 帕  
 Temperature:  $5^{\circ}\text{C} \sim 35^{\circ}\text{C}$       Relative humidity: 45%~85%      Air pressure: 8,600~10,600 pa

#### 2. 产品外观及尺寸要求 Appearance & Dimension Requirement

- 2.1 产品外形结构紧凑,无配合不良。  
The structure of product is compact, and assembly of parts has no badness.
- 2.2 产品塑胶部件无严重缩水、披锋、欠注、斑点、破损或变形现象。  
The plastic parts of product have no serious defects such as very serious shrink, scarcity, fleck, disrepair, transmutation, etc.
- 2.3 产品引脚和外壳无严重氧化、脏污、变形、毛刺或电镀不良。  
Lead feet and shell have no serious defects such as oxidation, smudge, disrepair, burr, defects on plating.
- 2.4 开关操作顺畅,节奏感强,无明显卡塞现象。  
Operating switch is unhindered, rhythmmed, and there is not palpable clag.
- 2.5 产品结构及尺寸参见产品规格图纸。  
Construction and dimensions: Refer to individual product drawing.

#### 3. 电气特性 Electronic Characteristics

No.	项 目 Item	测试方法 Test Method	测试设备 Equipment	特性要求 Requirements
3.1	接触电阻 Contact Resistance	在低电流 ( $\leq 100\text{mA}$ ) 条件下测试。 Measured at low current (100mA or less).	低电阻测试仪 Low Resistance Meter	$500\text{m}\Omega$ MAX
3.2	绝缘阻抗 Insulation Resistance	测试相邻引脚之间,引脚与外壳之间的绝缘阻抗。 Measurement shall be made between adjacent terminals, between terminal and shell.	绝缘测试机 Insulation Resistance Tester	$100\text{M}\Omega$ MIN
3.3	耐压测试 Dielectric Withstand Voltage	输入一定电压(50-60Hz,电压值 AC 500V)1分钟,漏电流为 2mA,测试邻近端子间。 Apply certain voltage (50-60Hz, AC 500V) for 1 minute between adjacent contacts of the connector with 2mA leakage sensitivity.	耐压测试机 Puncture Tester	没有绝缘破坏. 电弧等异常。 No arcing, break down and damaging insulation.

#### 4. 机械特性 Mechanical Characteristics

No.	项目 Item	测试方法 Test Method	测试设备 Equipment	特性要求 Requirements
4.1	操作力 Operation Force	<p>逐渐施力操作开关按键，测量开关到达全部工作行程时所需的最大操作力度。</p> <p>Operate the keystroke of the switch and then increase press strength gradually, Measured maximum operation force while the travel of the switch is full.</p>	测力计 Force Gauge	30±15gf

#### 5. 可靠性测试 Reliability trial

No.	项目 Item	测试方法 Test Method	测试设备 Equipment	特性要求 Requirements
5.1	可焊性试验 Solder ability Test	<p>端子顶部被浸入焊锡炉中，温度为 235±5℃，时间 5±1 秒。</p> <p>The top of the terminals shall be dipped in the solder bath at 235±5℃ for 5±1 seconds.</p>	控温锡炉 Solder Stove	<p>引脚至少 95%上锡。</p> <p>Ninety-five percent of terminals shall be dipped.</p>
5.2	寿命试验 Operation Life	<p>开关在寿命试验设备上以约 90 次 / 分的速度连续被操作，具体次数见规格图示。</p> <p>Switch shall be operated continuously at about 90 cycles /min without load.</p>	寿命试验机 Life Tester	<p>寿命:100000 次</p> <p>实验后:</p> <p>绝缘电阻: 10MΩ Min</p> <p>操作力: 变化在±50%内开关外观及结构无损坏。</p> <p>Life test:100000 cycles</p> <p>After test, Insulation resistance:10MΩ Min</p> <p>Operating force: Change should be within ±50% of specified value.</p> <p>No abnormalities shall be recognized in appearance and construction.</p>
5.3	耐焊接热 Resistance to Soldering heat	<p>端子焊接部分浸入焊炉，焊炉温度 235± 5℃，焊接时间 5±1 秒。(焊接时不可于端子施加外力)。</p> <p>Terminals shall be dipped in the solder bath at 235±5℃ for 5±1 seconds without additional force for terminals.</p>	控温锡炉 Solder Stove	<p>本体无变形，能满足于机械、电气性能。</p> <p>Appearance should be not damaged, electrical and mechanical characteristics shall be satisfied.</p>

**5. 可靠性测试 Reliability trial**

No.	项 目 Item	测试方法 Test Method	测试设备 Equipment	特 性 要 求 Requirements
5.4	耐高温测试 Resistance to Heat Test	放置在温度 $80\pm 2^{\circ}\text{C}$ 环境中 96 小时后，再置于正常条件下 1 小时后测定。 The switch shall be stored at a temperature of $80\pm 2^{\circ}\text{C}$ for 96 hours, Measurements shall be made after it be subjected to the standard conditions for 1 hour.	高低温试验机 High & Low Temperature Tester	外观，机械及电气性能均符合要求。 Appearance, electrical and mechanical characteristics shall be satisfied.
5.5	耐低温测试 Resistance to Cold Test	放置在温度 $-20\pm 2^{\circ}\text{C}$ 环境中 96 小时后，再置于正常条件下 1 小时后测定。 The switch shall be stored at a temperature of $-20\pm 2^{\circ}\text{C}$ for 96 hours, Measurements shall be made after it be subjected to the standard conditions for 1 hour.	高低温试验机 High & Low Temperature Tester	外观，机械及电气性能均符合要求。 Appearance, electrical and mechanical characteristics shall be satisfied.
5.6	耐湿性测试 Resistance to Humidity Test	放置于温度 $40\pm 2^{\circ}\text{C}$ ，相对湿度为 90~96% 环境中 96 小时后，再置于正常条件下 1 小时后测定(注意要擦去水滴)。 The switch shall be stored at a temperature of $40\pm 2^{\circ}\text{C}$ , relative humidity 90~96% for 96 hours, Measurements shall be made after it be subjected to the standard conditions for 1 hour (Wipe out water drip).	恒温恒湿箱 Temperature & Humidity Tester Chamber	外观，机械及电气性能均符合要求。 Appearance, electrical and mechanical characteristics shall be satisfied.
5.7	盐雾实验 Salt Mist Test	试件在下述实验后测量： 1. 温度： $35\pm 5^{\circ}\text{C}$ 2. 盐溶液浓度： $5\pm 1\%$ (质量百分比)， 3. 试验时间：24 小时， 4. 试验后，将盐沉积物用水冲掉。 The switch shall be checked after following test: 1. Temperature: $35\pm 5^{\circ}\text{C}$ 2. Salt solution: $5\pm 1\%$ (Solids by mass) 3. Duration: 24 hours, 4. After immersing, salt deposit shall be removed by running water.	盐雾试验机 Salt Spray Tester	在金属件上没有严重腐蚀斑点。 No remarkable corrosion shall be recognized in metal parts.