

ABIDE BY WEEE & ROHS

- Specification :
- 1. Rating:  
Voltage :12V AC/DC max., 2V DC min.  
Current: 10mA AC/DC max., 10μA DC min.
  - 2. Contact Resistance : 100m Ω Max
  - 3. Insulation Resistance :100M Ω at 500V
  - 4. Withstand Voltage : AC100V (50-60Hz) for 1 minute
  - 5. Mating Force :3.0kgf max
  - 6. Operating Life :5000 Cycles

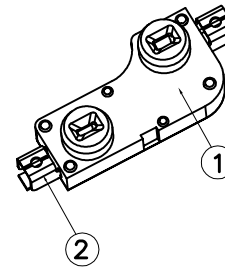

SECTION C-C

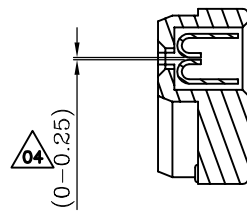
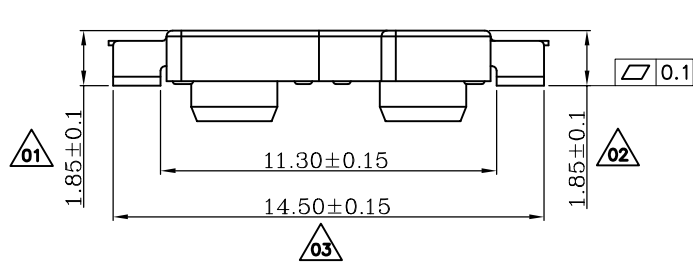
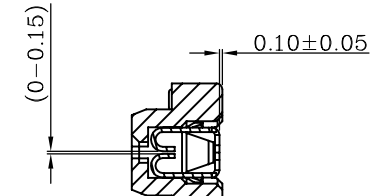
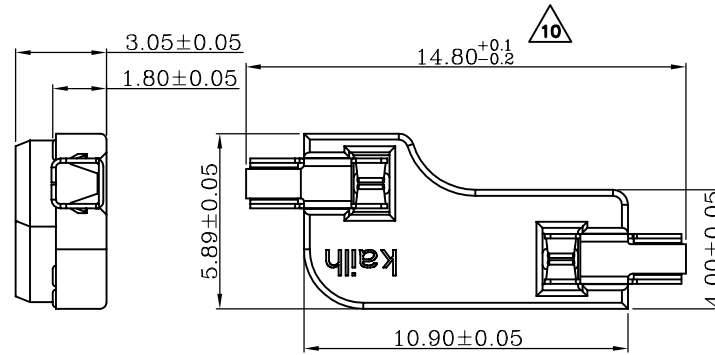
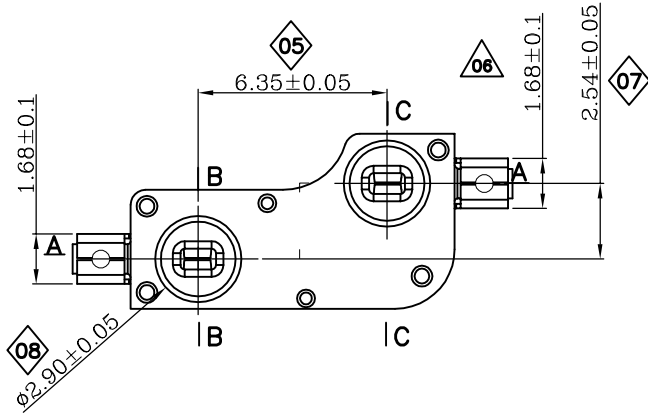

SECTION B-B

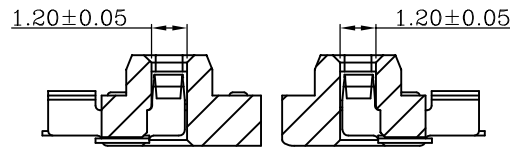

SECTION A-A

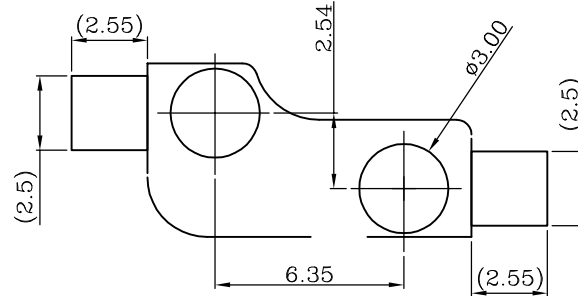

RECOMMENDED PCB LAYOUT  
TOLERANCE: ±0.05mm

ITEM	PART NAME	TER'NO.	QTY.	MATERIAL	FINISHING	REMARK
②	contact	—	1	Copper Alloy	Tin Plating	—
①	Base	—	1	Nylon	White	—
APPROVALS			DATE	东莞市凯华电子有限公司 KAIHUA ELECTRONICS CO., LTD		
DRAWN	HuHaixin	2021.10.06		TITLE:	PG1511 KeySwitches Socket	
CHECKED				PART NO:	CPG151101S11-1	
APPROVALS				UNIT: mm	SCALE: 1:1	PROJ:
TOLERANCES ARE				30<L ±0.30 10<L ≤30 ±0.20 5<L ≤10 ±0.15 L≤5 ±0.10	ANGLE UNIT: mm	SCALE: 1:1
ECN NO.	REV.	DATE.	DESCRIPTION.	CHANGE.	CHECK.	APPRO.
NEW						
DRAWING NO. KHA-PG1511-319EN				SHEET: 10F1		

ECN NO.	REV.	DATE.	DESCRIPTION.	CHANGE.	CHECK.	APPRO.
	A					



**凱華電子**  
KAIHUA EEELETRONICS

Document Number:

**KH-PS2110-07**

# 产品规格书

## Product Specification

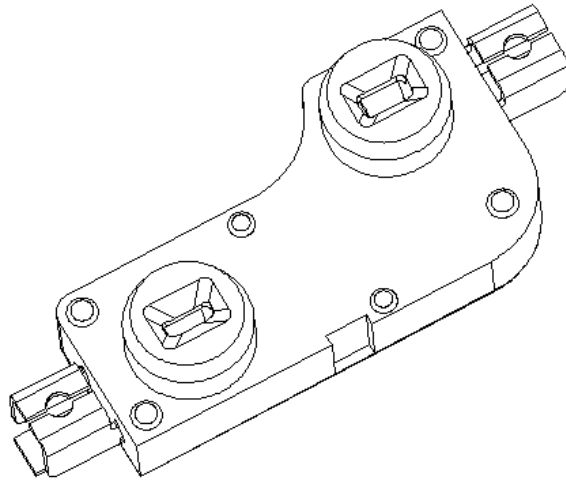

P/N:

**CPG151101S11-1**

Title :

**1511 Connector**

Rev.	ECN	Release and Revision Description:	Prepared By /Date:	Checked By/Date:	Approved By/Date:
A	_____	New releasing 初版发行	胡海鑫/2021.10.13	胡前程/2021.10.13	郑建军/2021.10.13



P/N: CPG151101S11-1	DOC. No.: KH-PS2110-07	Rev.: A	Page: 2/9
------------------------	---------------------------	------------	--------------

## Content

### 目录

1. Scope/范围:	3
2. Product Application/产品应用 :	3
3. Technology Parameters/技术参数	3
4. Ratings/额定性能要求	3
5. Profile Dimensions /外形尺寸	3
6. Electrical Performance/电气性能	4
7. Mechanical Performance/机械性能	5
8. Environmental Performance/环境性能	6-7
9. Recommended PCB Layout/推荐的 PCB 安装焊盘规格	8
10. Packaging/包装	8
11. Precaution/注意事项	8-9



<b>P/N:</b> CPG151101S11-1	<b>DOC. No.:</b> KH-PS2110-07	<b>Rev.:</b> A	<b>Page:</b> 3/9
-------------------------------	----------------------------------	-------------------	---------------------

**1. Scope/范围:**

This Product Specification covers the requirement of Mechanical keyboard Connector switch on product performance, test methods and quality assurance provisions.  
本规格书内容涵盖机械键盘连接器产品的要求，包括性能指标、测试方法及质量保证方面等。

**2. Product Application/产品应用:**

Mainly applied on computer keyboards, cash registers equipment and Man-Machine interface.  
主要适用于电脑，收银机，工业设备和人机界面

**3. Technology Parameters/技术参数**

Ambient Humidity 工作湿度:	45~95% R.H.;
Operating Temperature Range 使用温度范围:	-10℃~+60℃;
Storage Temperature Range 保存温度范围:	-20℃~+70℃;
Normal Condition:	
Ambient temperature 环境温度:	20±2℃
Relative humidity 相对湿度:	85%±5% R.H.;
Air pressure 气压:	86~101KPa;
Contact Resistance 接触阻抗:	100 m Ω Max;
Solder Ability 可焊性:	锡铅焊 245±5℃ 5±0.5s; 无铅焊 255±5℃ 5±0.5s;
Withstand Soldering Temperature 耐焊接热:	回流焊接: 260±5℃ 5±0.5s;

**4. Ratings/额定性能要求**

Rating Voltare 额定电压:	12V AC/DC max; 2V DC min
Rating Current 额定电流	10mA AC/DC max; 10uA DC min
InsulationResistance 绝缘电阻:	≥100MΩ/DC 500V;
Withstand Voltage 耐电压:	AC 100V 1 Minute;
Mechanical Life 机械寿命:	5000Cycles.

**5. Profile Dimensions /外形尺寸**

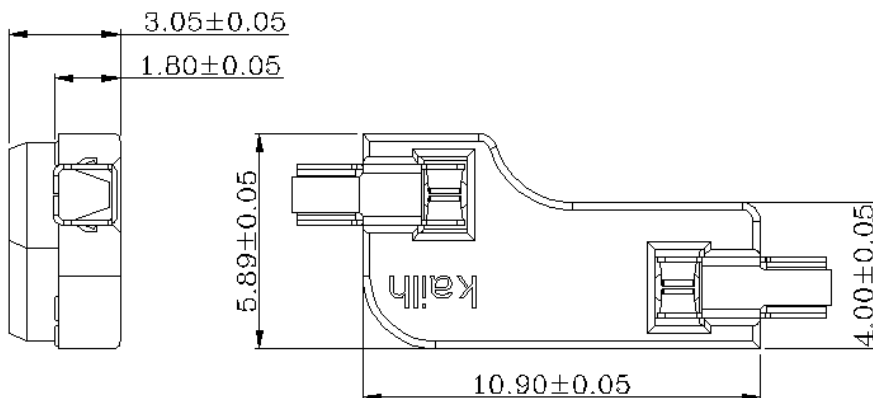



**6. Electrical Performance/电气性能**

Item 项目	Description 项目描述	Test Condition 测试条件	Requirement 规格要求
6.1	Contact Resistance 接触电阻	Static load: (Operation force)x2, which is applied on the center of Switch stem. 静态负载: 动作力的 2 倍, 施加在手柄中心.  Measurement tool: Contact resistance Meter. 测量工具: 微电流接触电阻计(1KHz, 20mV,5~50mA)	100mΩ Max 100mΩ以下
6.2	Insulation Resistance 绝缘电阻	Apply a Voltage of DC 500 V for 1 minute, according to the below method. (1) Between terminals. (2) Between terminal and Body.  输入 500V DC 电压 1 分钟, 按如下接触方法测试: (1) 端子与端子之间. (2) 端子与外壳之间.	100MΩ Min 100 兆欧以上
6.3	Dielectric withstanding voltage 耐电压	Apply a Voltage of AC 100 V (50~60Hz) for 1 minute, according to the below method. (1) Between terminals. (2) Between terminal and Body.  输入 100V AC 电压 1 分钟, 按如下接触方法测试: (1) 端子与端子之间. (2) 端子与外壳之间.	No evidence of breakdown 无瞬断、击穿等破坏.

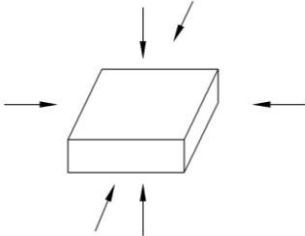

**7. Mechanical Performance/机械性能**

Item 项目	Description 项目描述	Test Condition 测试条件	Requirement 规格要求
7.1	Mating force 插入力	At 16in/minute.actuation speed	Mating force 插入力 3KG max
7.2	Unmating force 拔出力	At 16in/minute.actuation speed	Unmating force 拔出力 200gf min
7.3	Shock 机械冲击	<p>Measured by according to the below condition:            (1) Acceleration: 80g 加速度            (2) Cycles of test:3 cycles each in 6 directions, for a total of 18 cycles.            试验次数: 每个方向 3 次, 6 个方向共 18 次.</p> 	<p>Appearance: No abnormality. 外观无异常</p>
7.4	Life Test 寿命测试	<p>(1) No load 无负载            (2) Mating force: Maximum value of operation force.            插入力: 操作力规格值的上限.            (3) Cycles: 5000 Min            操作次数: 5000 次以上</p>	<p>Contact resistance: 1000 mΩ Max            接触电阻: 1000 毫欧以下            Bouncing: 10ms Max            触点抖动: 10 毫秒以下</p>



**8. Environmental Performance/环境性能**

Item 项目	Description 项目描述	Test Condition 测试条件	Requirement 规格要求												
8.1	Cold test 耐寒性	(1) Temperature : - 20±2°C 温度: - 20±2°C (2) Duration of test: 48h 持续时间: 48 小时 (3) Take off a drop water 去掉水珠 (4) Standard conditions after test : 1h 试验后的放置条件: 1 小时	Contact resistance: 200m Ω Max 接触电阻 200m Ω 以下												
8.2	Heat test 耐热性	(1) Temperature : 70±2°C 温度: 70±2°C (2) Duration of test: 48h 持续时间: 48 小时 (3) Take off a drop water 去掉水珠 (4) Standard conditions after test : 1h 试验后的放置条件: 1 小时	Contact resistance: 200m Ω Max Shall meet : No. 6.2 接触电阻 200m Ω 以下 满足: No. 6.2												
8.3	Temperature cycle 温度循环	(1) Test cycles: 5 cycles 试验周期: 5 个周期 (2) Standard condition after test:1h 试验后的放置条件: 1 小时 <table border="1" style="margin-top: 10px;"> <thead> <tr> <th></th> <th>Temperature 温度</th> <th>Duration of test 持续时间</th> </tr> </thead> <tbody> <tr> <td rowspan="4">1 cycle 一次循环</td> <td>20±5°C</td> <td>1h</td> </tr> <tr> <td>-20±5°C</td> <td>1h</td> </tr> <tr> <td>20±5°C</td> <td>1h</td> </tr> <tr> <td>70±5°C</td> <td>1h</td> </tr> </tbody> </table>		Temperature 温度	Duration of test 持续时间	1 cycle 一次循环	20±5°C	1h	-20±5°C	1h	20±5°C	1h	70±5°C	1h	Contact resistance: 200m Ω Max Shall meet : No. 6.2 接触电阻 200m Ω 以下 满足: No. 6.2
	Temperature 温度	Duration of test 持续时间													
1 cycle 一次循环	20±5°C	1h													
	-20±5°C	1h													
	20±5°C	1h													
	70±5°C	1h													
8.4	Soldering heat test 耐焊接热	Soldering area: T/2 of PWB thickness. (PWB: T=1.6mm) 焊接面积: 印刷基板的 1/2 厚度处 Soldering temperature: 260±5°C Soldering time: 5±0.5s 焊接温度: 260±5°C 焊接时间: 5±0.5 秒 <div style="text-align: center; margin-top: 10px;"> <p>SMT回流焊温度曲线图</p> </div>	Appearance: No abnormality. 外观无异常												



8.5	Solderability 可焊性	<p>Lead-tin soldering 锡铅焊接: Soldering temperature: 245±5°C Soldering time: 5±0.5s 焊接温度: 245±5°C 焊接时间: 5±0.5 秒</p> <p>Lead free soldering 无铅焊接: Soldering temperature: 255±5°C Soldering time: 5±0.5s 焊接温度: 255±5°C 焊接时间: 5±0.5 秒</p>	<p>At least 90% of surface area of immersed portion shall be covered by solder. 侵焊面积大于 90%以上.</p>
8.6	Humidity test 耐湿性	<p>(1) Temperature : 60±2°C 温度: 60±2°C</p> <p>(2) relative humidity: 90~95% R.H. 相对湿度:90~95% R.H.</p> <p>(3) Duration of test: 48h 持续时间: 48 小时</p> <p>(4) Take off a drop water 去掉水珠</p> <p>(5) Standard conditions after test: 1h 试验后的放置条件: 1 小时</p>	<p>Contact resistance: 200m Ω Max Shall meet : No. 6.2 接触电阻 200m Ω 以下 满足: No. 6.2</p>
8.7	Salt Spray 盐雾测试	<p>Apply the following environment to test: 根据下列条件进行测试:</p> <p>(1) Temperature : 35±5°C 温度: 35±5°C;</p> <p>(2) Salt water density: 5±1% 盐水浓度: 5±1%;</p> <p>(3) Duration: 12 hours 持续时间: 12 小时;</p> <p>(4) After test, the salt deposit shall be removed by running water. 实验后将盐沉积物用水冲掉</p>	<p>Appearance: No corrosion spot, no crack, no base plate naked. 外观: 无腐蚀点, 无裂纹, 无裸露基材.</p> <p>Contact Resistance: 200 m Ω Max 接触电阻: 200 毫欧以下</p>





**9. Recommended PCB Layout 推荐的 PCB 安装焊盘规格**

(Top View)  
(Single face board T=1.6mm)

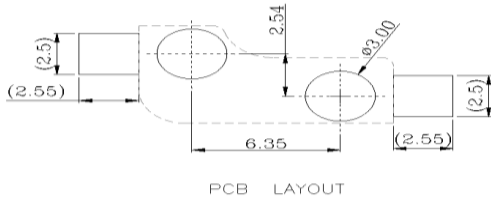

**10. Packaging 包装**

Packaging type: 13Tray, 26000Pcs/Carton.

包装方式:13 /盘, 26000Pcs/箱.

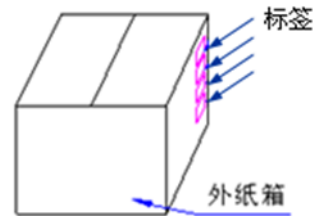
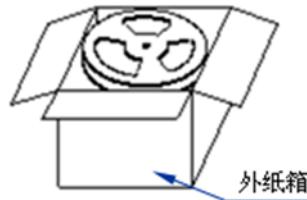
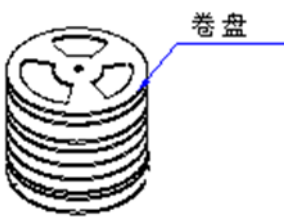

**11. Precaution 注意事项**

**11.1 Soldering condition 回流焊条件**

ITEM 项目	CONDITION 条件	
Preheating zone 预热区	Heating zone 升温区	Speed <math>< 2^{\circ}\text{C}/\text{S}</math>, Preheating time 15 S Max, temperature 150°C 速度 <math>< 2^{\circ}\text{C}/\text{S}</math>, 预热时间 15 S 最多, 温度 150°C
	Heatpreservati on area 保温区	Speed 1.2~3.5°C/S, Preheating time 120 S Max, temperature 180°C 速度 1.2~3.5°C/S, 预热时间 120 S 最多, 温度 180°C
	Fast heating zone 快速升温区	Speed 3.5~4.5°C/S, Preheating time 140 S Max, temperature 230°C 速度 3.5~4.5°C/S, 预热时间 140 S 最多, 温度 230°C
Weld area 焊接区	Welding time 40 S Max, welding temperature peak value, 3 sec Max. 焊接时间 40 S 最多, 焊接温度峰值 260°C 最大, 3 S 最多	
Area of flux 助焊剂面积	1/2 Max of PWB Thickness 印刷基板厚度的 1/2 以内	
Temperature of solder 焊锡温度	260 ± 5°C 260 ± 5°C	
Number of soldering 焊接次数	2time Max (But should down heat of the first soldering) 2 次以内	
Printed wiring board 印刷基板	Single side copper-clad laminates 单面铜箔	

(1) After reflow, be careful not to clean switches with solvent

回流焊后, 注意不要溶剂清洗.

(2) Under the condition of using soldering iron, soldering temperature shall be 350°C max within 3 sec.

在使用烙铁的情况下, 焊锡温度应在 350°C 以下, 焊接时间 3 秒以内.



P/N:	DOC. No.:	Rev.:	Page:
CPG151101S11-1	KH-PS2110-07	A	9/9

### 11.2 Notes 注意点

- (1) Please be cautious not to give excessive static load connector.  
注意不要施加超负荷的压力或晃动连接器。
- (2) Connector be careful not to stack up P. W. B. after switches were soldered.  
连接器焊接以后,印刷基板注意不要叠放。
- (3) Preservation under high temperature and high humidity or corrosive gas should be avoided  
Especially. When you need to preserve for a long period, do not open the carton.  
保管时尤其应注意避开高湿高温和有腐蚀性气体的环境.如需长时间保存,请不要打开包装箱。
- (4) The standard storage period is 3 months, with maximum up to 6months, preferably to be used as soon as possible. After opening the package, you should put the remaining switches in a plastic bag to prevent from damp and corrosive gas.  
保存标准为 3 个月, 限度为 6 个月以内, 请尽早使用. 打开包装后, 有剩余品时, 应将剩余部分以胶袋包装好以同外界隔离, 请进行合适的防湿, 防腐蚀气体等处理后进行保管。
- (5) This Product Specification is considered as the technical agreement on product between the receiving customer and Kailh. Any information on Product Catalogue which is in conflict with or different from the corresponding information of this document is considered as invalid.  
该规格书为客户与凯华公司产品在技术方面的共识,其他相关数据上与该规格书不一致的内容都是无效的。
- (6) If customer issue purchase orders without confirmation by signature of this specification after receipt, such confirmation will be considered as granted upon receipt of the first purchase order.  
如果顾客收到规格书后没有信息反馈而直接向我公司订货,我们将认为贵客已接受此规格书。
- (7) If there is no order or no request for new specification after 1 year upon this specification is issued, the specification will be regarded as invalid.  
本产品规格书从生效日起 1 年后, 如果没有订货或再次申请最新规格书时请做无效处理。
- (8) Products meet the ROHS & REACH environmental management substances control standards  
产品满足 **ROHS & REACH** 环境管理物质管制标准