

# F2 行程开关

## LXW5 微动开关



### 选型指南

| 产品名称 | 触头代码       | 操动形式   |
|------|------------|--|
| LXW5 | □          | □  |
|      | 11: 一常开一常闭 | D1:短弹簧柱塞型<br>M:面板安装柱塞型<br>Q1:面板安装滚轮柱塞型<br>Q2:面板安装横向滚轮柱塞型<br>N1:铰链杠杆型<br>N2:铰链短杠杆型<br>G1:铰链滚轮长杠杆型<br>G2:铰链滚轮短杠杆型<br>G3:铰链滚轮中杠杆型 |

### 产品特征

- 用于机械、纺织、电子仪器等机械设备的行程控制保护和联锁之用

### 技术参数

| 型号             | 动作力(max)  | 复位力(min)         | 重复精度误差 | 动作行程 |
|----------------|-----------|------------------|--------|------|
|                | N         | N                | mm     | mm   |
| LXW511D1       | 2~3.8     | 1                | ±0.05  | ≤1   |
| LXW511M        | 2~3.8     | 1                | ±0.05  | ≤1   |
| LXW511Q1       | 2~3.8     | 1                | ±0.05  | ≤1   |
| LXW511Q2       | 2~3.8     | 1                | ±0.05  | ≤1   |
| LXW511N1       | 0.3~0.8   | 0.15             | ±0.05  | 2~4  |
| LXW511N2       | 0.5~1     | 0.25             | ±0.05  | 3~5  |
| LXW511G1       | 0.35~0.85 | 0.15             | ±0.05  | ≤3   |
| LXW511G2       | 0.8~1.6   | 0.25             | ±0.05  | 2~4  |
| LXW511G3       | 0.4~0.9   | 0.2              | ±0.05  | 3~6  |
| 额定绝缘电压(Ui)     | V         | 380              |        |      |
| 额定工作电压(Ue)     | V         | 380(AC), 220(DC) |        |      |
| 额定工作电流(Ie)     | A         | 2.5(AC), 0.3(DC) |        |      |
| 约定发热电流(Ith)    | A         | 3                |        |      |
| 额定冲击耐受电压(Uimp) | V         | 6000             |        |      |
| 额定控制容量         | VA        | 100(AC)          |        |      |
| 额定控制容量         | W         | 10(DC)           |        |      |
| 防护等级           |           | IP62             |        |      |
| 国家标准           |           | GB/T14048.5      |        |      |
| 认证证书           |           | CCC、ISO9001      |        |      |

# F2 行程开关

## LXW5 微动开关

### 外形及安装尺寸(mm)

■ LXW5-11Q1

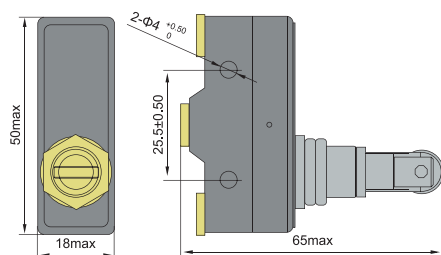

■ LXW5-11Q2

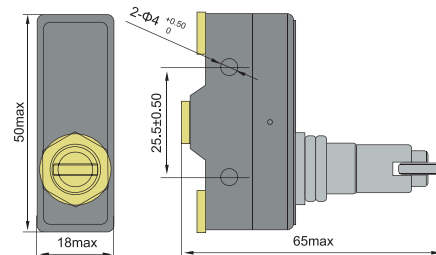

■ LXW5-11D1

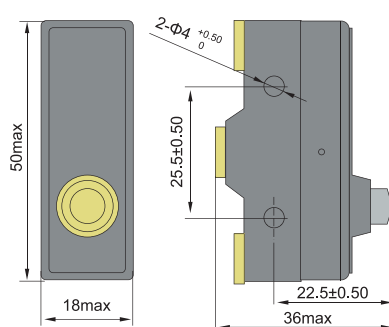

■ LXW5-11M

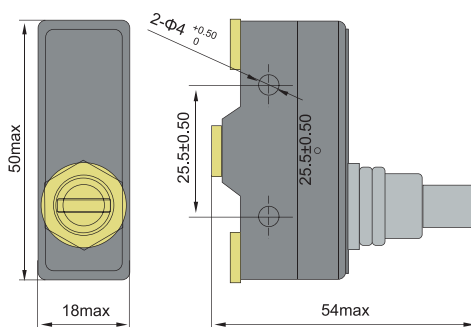

■ LXW5-11G1, G2, G3

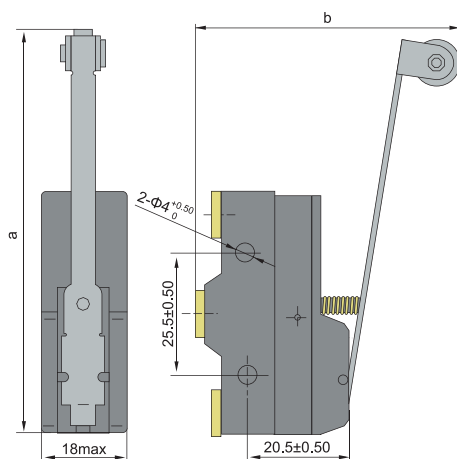

■ LXW5-11N1, N2

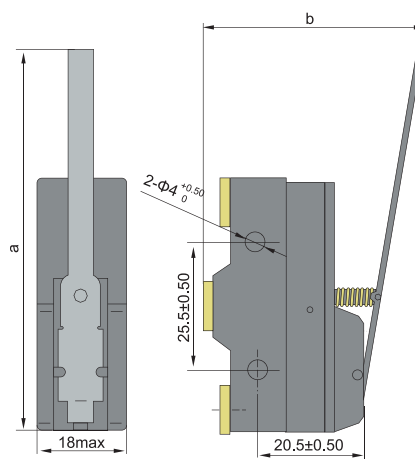

| 型号        | a  | b             |
|-----------|----|---------------|
| LXW5-11G1 | 66 | 52            |
| LXW5-11G2 | 50 | 49            |
| LXW5-11G3 | 60 | 52(最大),47(最小) |

| 型号        | a  | b  |
|-----------|----|----|
| LXW5-11N1 | 76 | 43 |
| LXW5-11N2 | 50 | 38 |