

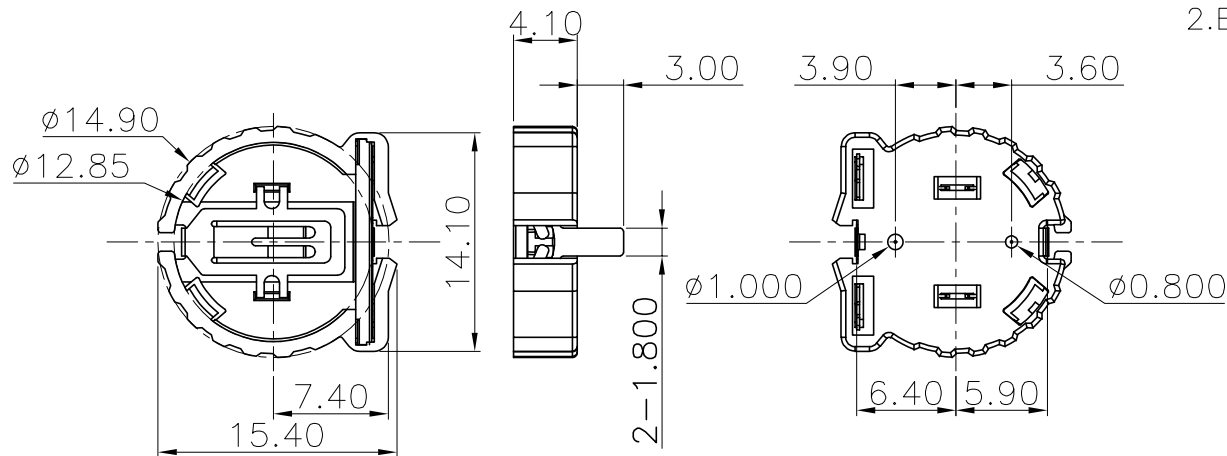

REV.	ECN NO.	REVISED	DATE

1.MATERIAL:  
 a.HOUSING:PPS  
 b.CONTACT:PHOSPHOR BRONZE  
 (SURFACE PLATING:AU1u")  
 SEE ORDERING INFORMATION

2.ELECTRIC:  
 a.CONTACT RESISTANCE: 30 MILLIOHMS MAX  
 b.INSULATION RESISTANCE: 100 MEGA OHMS MIN  
 c.DIELECTNIC VOLTAGE: 500V AC ONE SEC LEVEL  
 d.OPERATING TEMPERATURE: -25°C~ +85°C



### ORDERING INFORMATION

## BS-12-A3AA003

电池座系列

BS-12系列

DIP 90° TYPE

PLATING:  
 A-Au1U"  
 J-Ni100U"~120U"  
 K-Sn100U"~120U"

MATERIAL:  
 1A-PBT BLACK  
 1B-PA66 BLACK  
 2A-PPA BROWN  
 2B-PPA BLACK  
 3A-PPS BROWN  
 3B-PPS BLACK  
 4A-LCP WHITE  
 4B-LCP BLACK

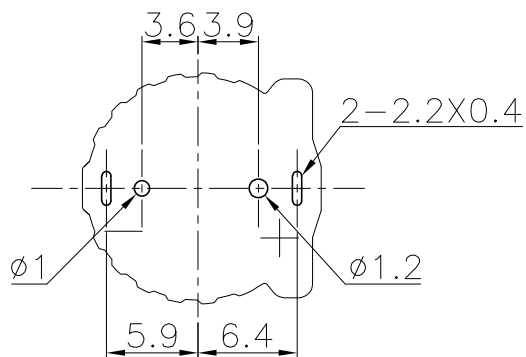

PCB Layout Diagram  
Top View



3	TERMINAL(-)	1	PHOSPHOR BRONZE, T=0.20mm	Gold Plating and Ni Under-Plating
2	TERMINAL(+)	1	PHOSPHOR BRONZE, T=0.20mm	Gold Plating and Ni Under-Plating
1	HOUSING	1	PPS	BROWN
NO.	PART NAME	Q'TY	MATERIAL	PLATING & COLOR

UNLESS OTHERWISE SPECIFIED TOLERANCES		<b>MYOUNG 美用</b> <a href="http://www.meiyangdz.com">www.meiyangdz.com</a>			
DECIMALS: X :±0.30 X.X :±0.25 X.XX :±0.20 X.XXX :±0.10	ANGLES: X :±1° X.X :±0.5°	DSND	YangFeng	DATE	2019-12-09
		CHKD	ZhouRuicai	DATE	2019-12-09
		APVD	XueShunyong	DATE	2019-12-09
WEIGHT: 0.63g		SCALE: 2:1		SIZE: A4	VIEW:
SHEET 1 OF 1		UNIT: mm	REV.: A/0	OBJECT: MY	DRAW NO.:MY-CP-0305
		TITLE:		BS-1220-2 PPS DIP	
		PART NO.:		BS-12-A3AA003	