

Features

- Uses advanced SGT technology
- Extremely low on-resistance $R_{DS(on)}$
- Excellent gate charge x $R_{DS(on)}$ product(FOM)

Application

- Motor control and drives
- Battery management
- DC/DC converter
- General purpose applications

Product Summary

	TOLL
V_{DS}	80V
$R_{DS(on)}@V_{GS}=10V$	3.6m Ω
I_D	120A

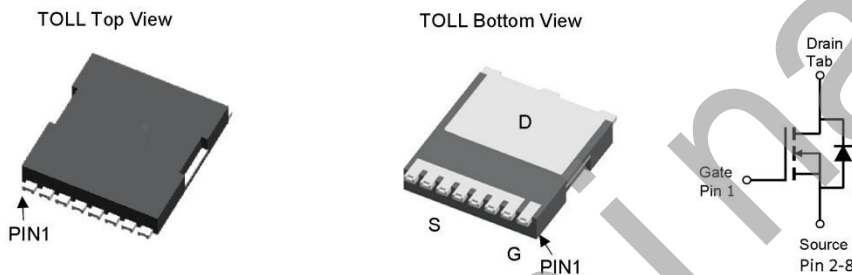

Package Marking and Ordering Information

Type	Package	Marking	Reel Size	Tape Width	Packing	Qty
LR046N08SA10	TOLL	LR046N80SA10	330*28.5mm	24mm	Reel&Tape	2000

Maximum Ratings

Parameter	Symbol	Value	Unit
Drain-source voltage	V_{DS}	80	V
Continuous drain current $T_C = 25^\circ\text{C}$ (Silicon limit) $T_C = 25^\circ\text{C}$ (Package limit) $T_C = 100^\circ\text{C}$ (Silicon limit)	I_D	150 120 100	A
Pulsed drain current ($T_C = 25^\circ\text{C}$, t_p limited by T_{jmax})	$I_{D\ pulse}$	480	
Avalanche energy, single pulse ($L=0.5\text{mH}$, $R_g=25\Omega$)	$E_{AS(max)}$	841	mJ
Gate-Source voltage	V_{GS}	± 20	V
Power dissipation ($T_C = 25^\circ\text{C}$)	P_D	196	W
Operating junction and storage temperature	T_j, T_{stg}	-55~150	$^\circ\text{C}$

Thermal Resistance

	Symbol	Value	Unit
Thermal resistance, junction – case. Max	R_{thJC}	0.6	°C/W
Thermal resistance, junction – ambient. Max	R_{thJA}	58	

Electrical Characteristic, at T_j = 25 °C, unless otherwise specified

Parameter	Symbol	Test Condition	Value			Unit
			min.	typ.	max.	

Static Characteristic

Drain-source breakdown voltage	$V_{(BR)DSS}$	$V_{GS}=0V, I_D=250\mu A$	80	-	-	V
Gate threshold voltage	$V_{GS(th)}$	$V_{DS}=V_{GS}, I_D=250\mu A$	2	3	4	
Zero gate voltage drain current	I_{DSS}	$V_{DS}=80V, V_{GS}=0V$ $T_j=25^\circ C$	-	-	1	μA
		$V_{DS}=64V, V_{GS}=0V$ $T_j=125^\circ C$	-	-	10	
Gate-source leakage current	I_{GSS}	$V_{GS}=20V, V_{DS}=0V$	-	-	100	nA
Drain-source on-state resistance	$R_{DS(on)}$	$V_{GS}=10V, I_D=50A,$ $T_j=25^\circ C$	-	3.6	4.6	mΩ
Transconductance	g_{fs}	$V_{DS}=5V, I_D=50A$	170	-	-	S

Dynamic Characteristic

Input Capacitance	C_{iss}	$V_{GS}=0V, V_{DS}=40V,$ $f=1MHz$	-	4027	-	pF
Output Capacitance	C_{oss}		-	1207	-	
Reverse Transfer Capacitance	C_{rss}		-	33	-	
Gate Total Charge	Q_G	$V_{GS}=10V, V_{DS}=50V,$ $I_D=50A, I_D=20A$	-	64	-	nC
Gate-Source charge	Q_{gs}		-	19	-	
Gate-Drain charge	Q_{gd}		-	17	-	
Turn-on delay time	$t_{d(on)}$	$T_j=25^\circ C, V_{GS}=10V,$ $V_{DS}=50V, R_L=3\Omega$	-	26	-	ns
Rise time	t_r		-	47	-	
Turn-off delay time	$t_{d(off)}$		-	54	-	
Fall time	t_f		-	28	-	
Gate resistance	R_G	$V_{GS}=0V, V_{DS}=0V,$ $f=1MHz$	-	3	-	Ω

LR046N08SA10 N-MOSFET 80V, 120A, 3.6mΩ

Body Diode Characteristic

Body Diode Forward Voltage	V_{SD}	$V_{GS}=0V, I_{SD}=50A$	-	0.8	1.2	V
Body Diode Reverse Recovery Time	t_{rr}	$I_F=30A,$ $dI/dt=500A/\mu s$	-	66	-	ns
Body Diode Reverse Recovery Charge	Q_{rr}	$I_F=30A,$ $dI/dt=500A/\mu s$	-	80	-	nC

preliminary

Typical Performance Characteristics

Fig 1: Output Characteristics

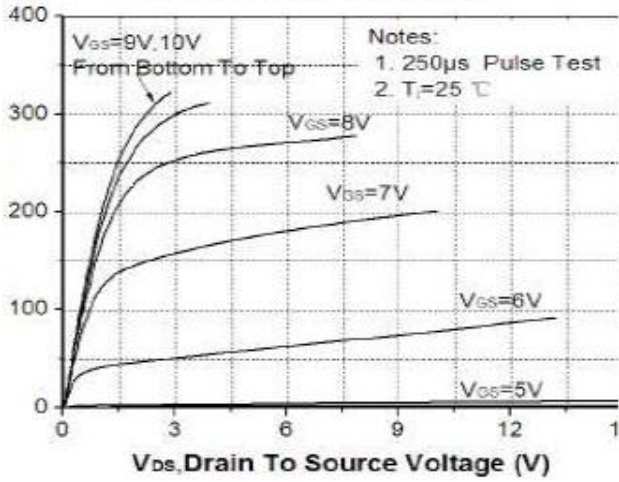

Fig 2: Transfer Characteristics

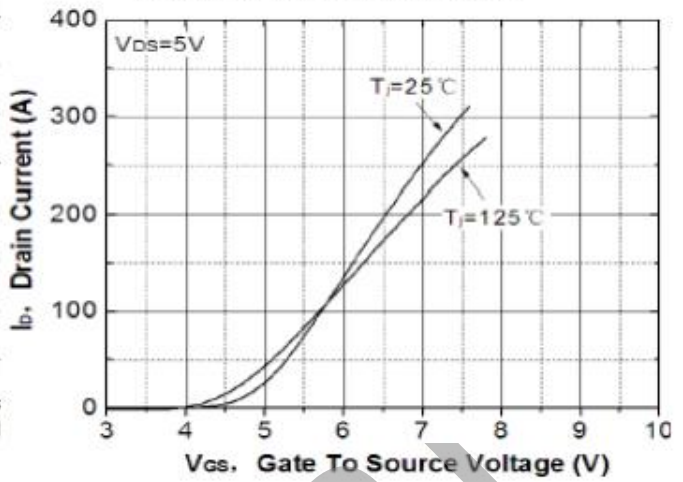

Fig 3: R_{DS(on)} vs Drain Current and Gate Voltage

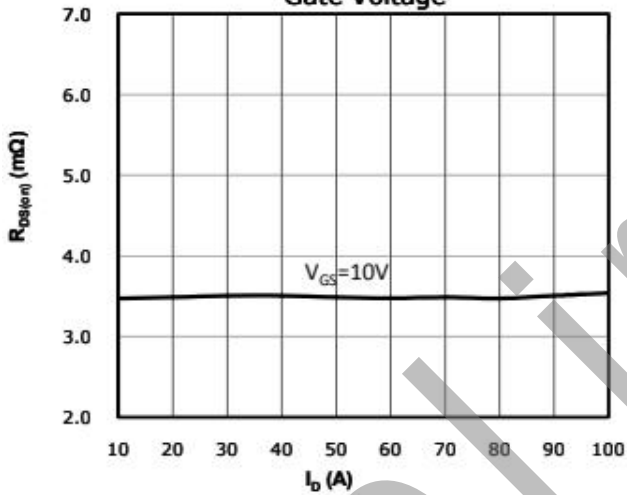

Fig 4: R_{DS(on)} vs Gate Voltage

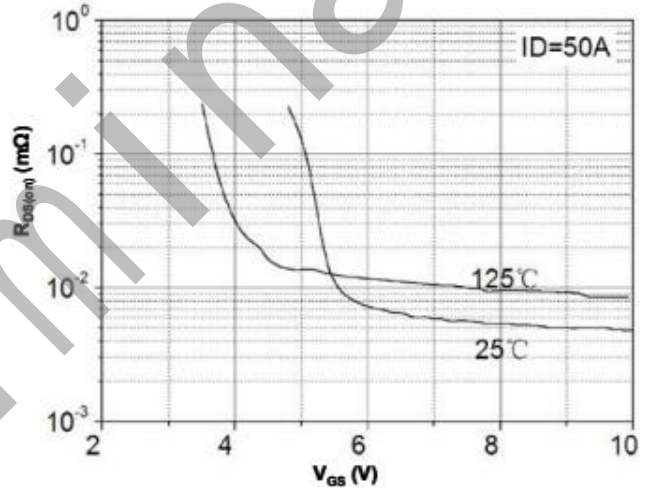

Fig 5: R_{DS(on)} vs. Temperature

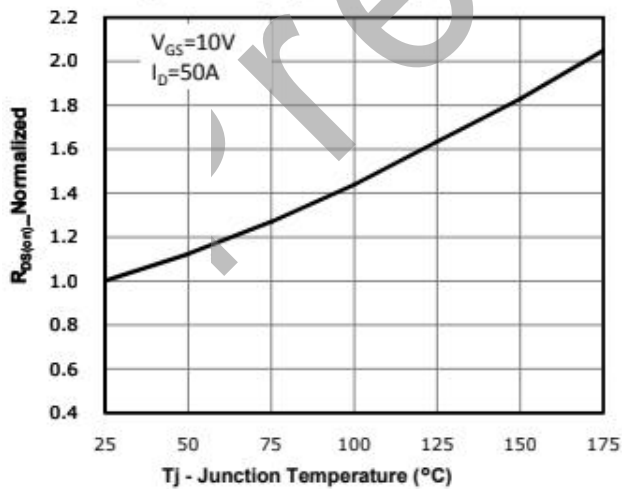

Fig 6: Capacitance Characteristics

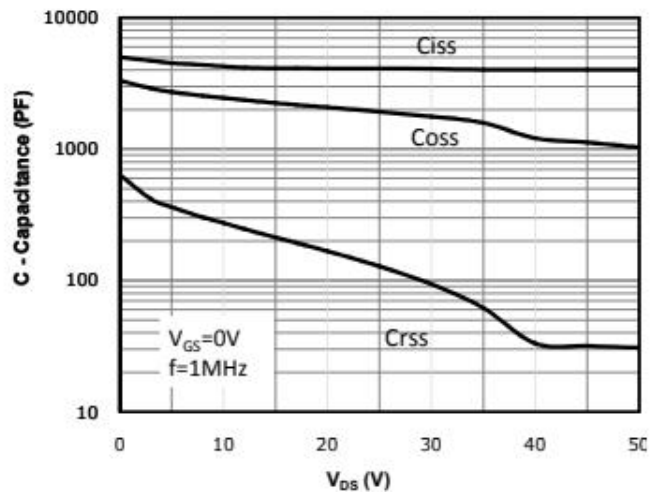

Fig 7: Gate Charge Characteristics

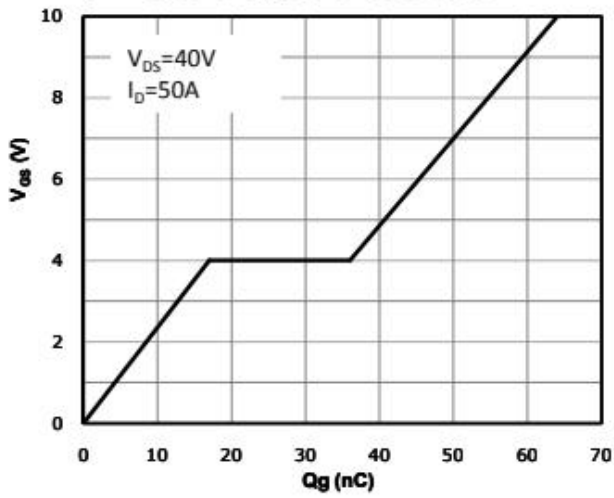

Fig 8: Body-diode Forward Characteristics

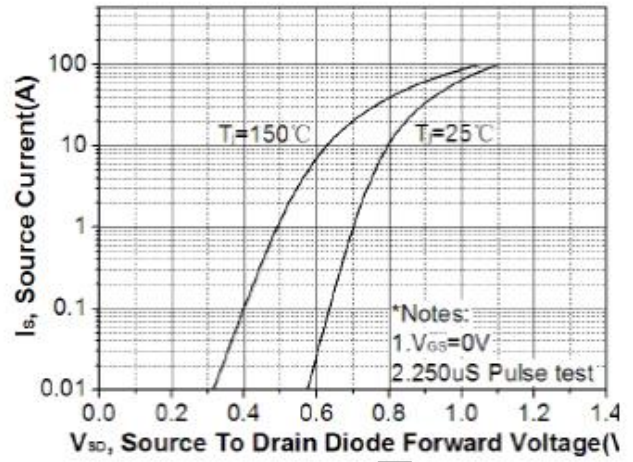

Fig 9: Power Dissipation

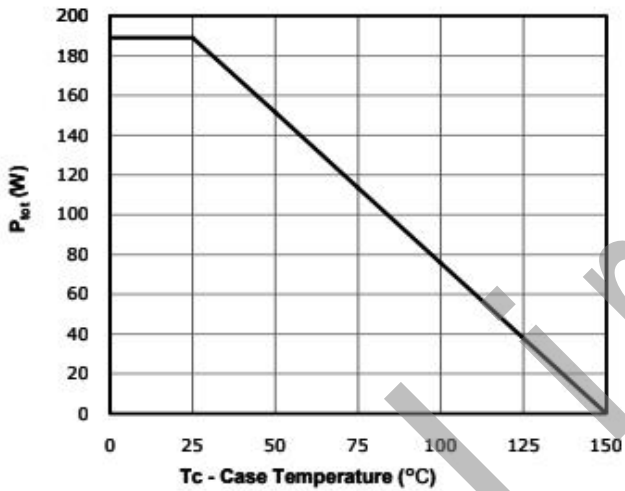

Fig 10: Drain Current Derating

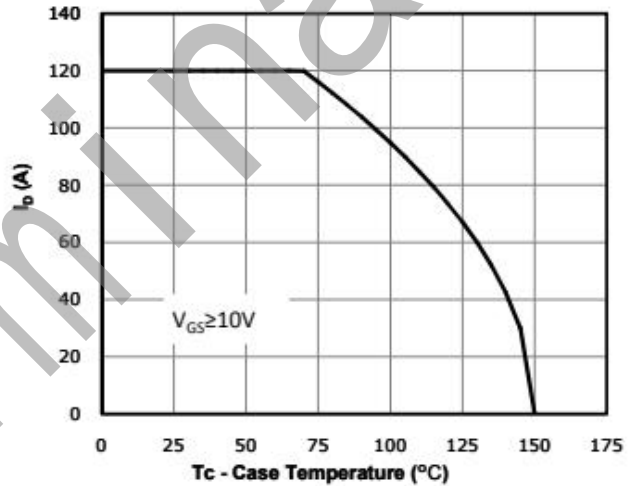

Fig 11: Safe Operating Area

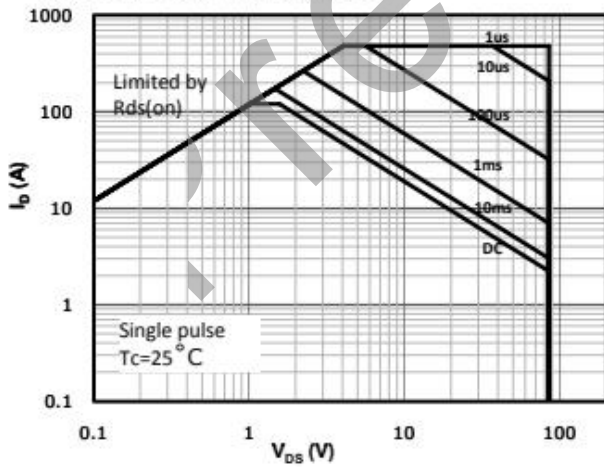
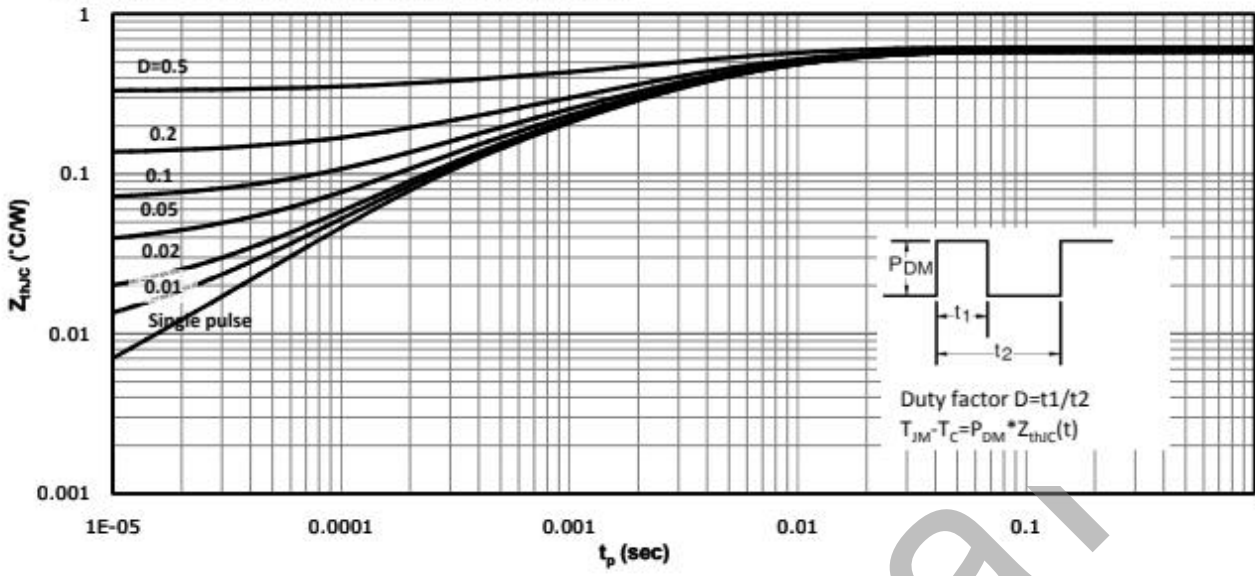
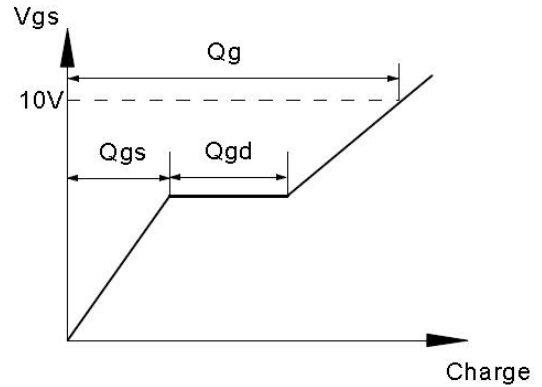
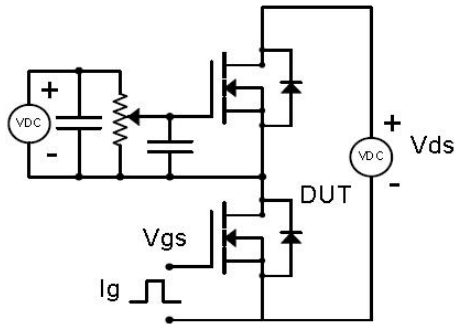

Fig 12: Max. Transient Thermal Impedance



Test Circuit & Waveform

Gate Charge Test Circuit & Waveform



Resistive Switching Test Circuit & Waveforms

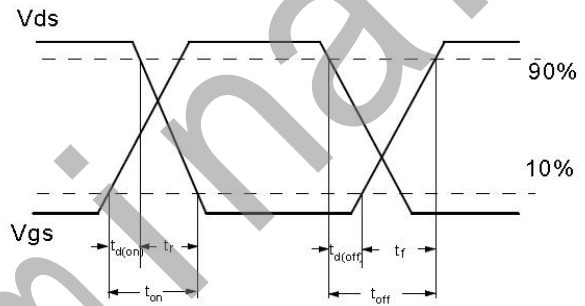
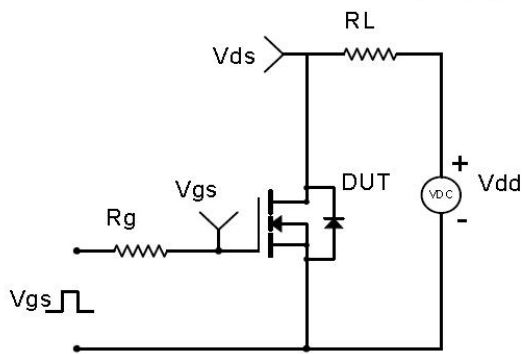

Unclamped Inductive Switching (UIS) Test Circuit & Waveforms

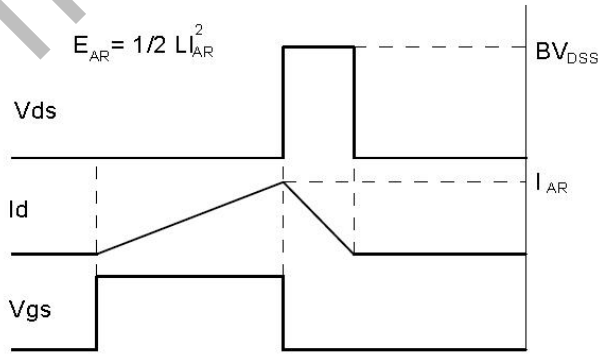
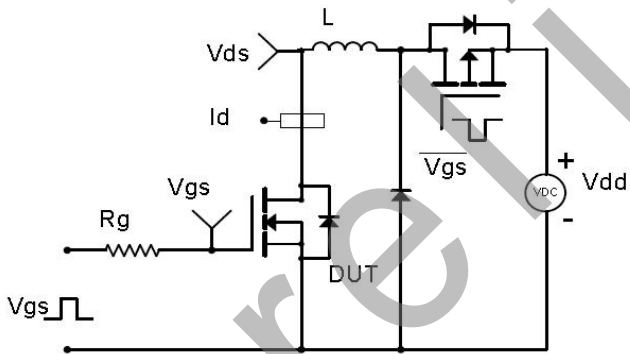

LR046N08SA10 N-MOSFET 80V, 120A, 3.6mΩ

Package Outline: TOLL

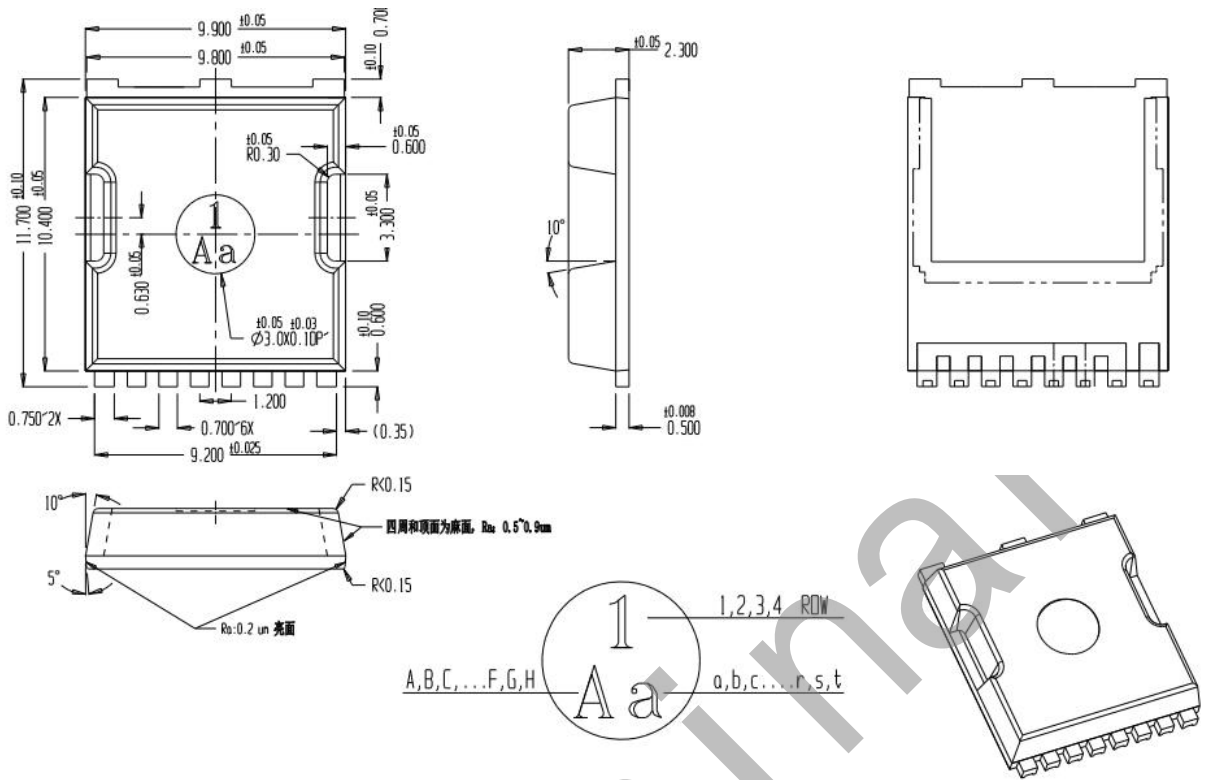

Revision History

Revision	Date	Major changes
0.0	2022/1/10	Preliminary Revision

Preliminary