

100V Input, 1.5A Current Limit, Non-synchronous Step-down Converter

The HT1015A is a high voltage, non-synchronous step-down converter operates over a wide range input voltage 9V to 100V. The HT1015A integrates a 120-V 400-m Ω high-side MOSFET. The HT1015A delivers 1A continuous load current with up to 95% efficiency. The HT1015A operates with fixed frequency peak current control with built-in compensation eliminates the need for external components. Cycle-by-cycle current limit in high-side MOSFET protects the converter in an overload condition. Hiccup mode protection is triggered if the over-current condition has persisted for longer than the present time. The HT1015A exhibits protection features that protect the load from faults like under-voltage, over-current and over-temperature.

Features

- 9V to 100V input voltage range
- 1.5A current limit
- 1A continuous load current
- 95% Peak Efficiency
- 400 μ A operating quiescent current
- 120V 400-m Ω high-side MOSFET
- Peak Current mode control
- 150 kHz Fixed Frequency
- Internal compensation for ease of use
- Up to 92% duty cycle
- 0.8V voltage reference
- 1 μ A shutdown current
- 150ms Hiccup mode short circuit protection

Function

Applications

- Charger in vehicle
- Battery Chargers
- Power adapter

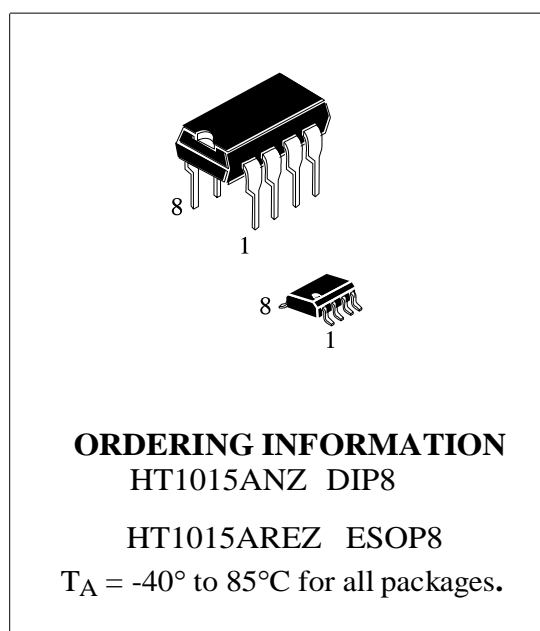

Efficiency vs Output Current

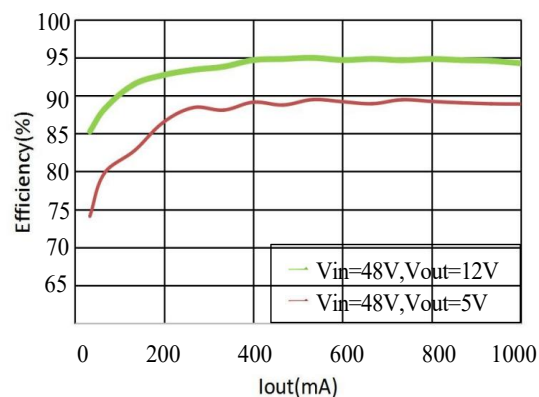

Typical Application

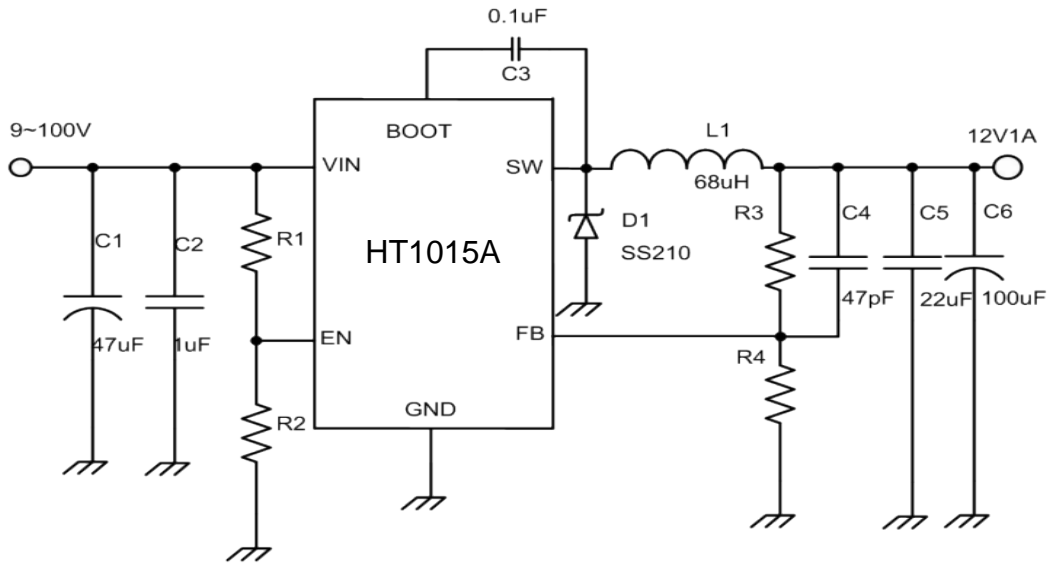

Pin Configuration

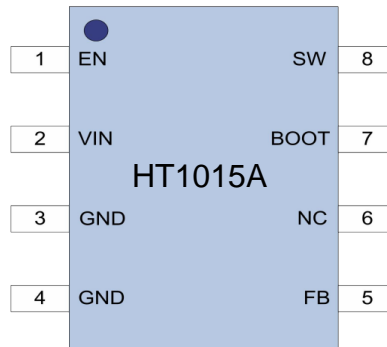

| PIN | NAME | Description |
|------|------|--|
| 1 | EN | Enable input. Pull EN below the specified threshold to shut down the HT1015A. Pull EN above the specified threshold to enable the HT1015A. |
| 2 | VIN | Input supply. VIN supplies power to all of the internal control circuitry, both BOOT regulators, and the high-side switch. |
| 3, 4 | GND | Ground. GND should be placed as close to the output capacitor as possible to avoid the high-current switch paths. Connect the exposed pad to GND plane for optimal thermal performance. |
| 5 | FB | Feedback. FB is the input to the voltage hysteretic comparator. The average FB voltage is maintained at 800mV by loop regulation. |
| 6 | NC | No Connection |
| 7 | BOOT | Bootstrap. BOOT is the positive power supply for the internal, floating, high-side MOSFET driver. Connect a bypass capacitor between BOOT and SW. |
| 8 | SW | Switch node. SW is the output from the high-side switch. A low forward voltage schottky rectifier to ground is required. The rectifier must be placed close to SW to reduce switching spikes. |

Block Diagram

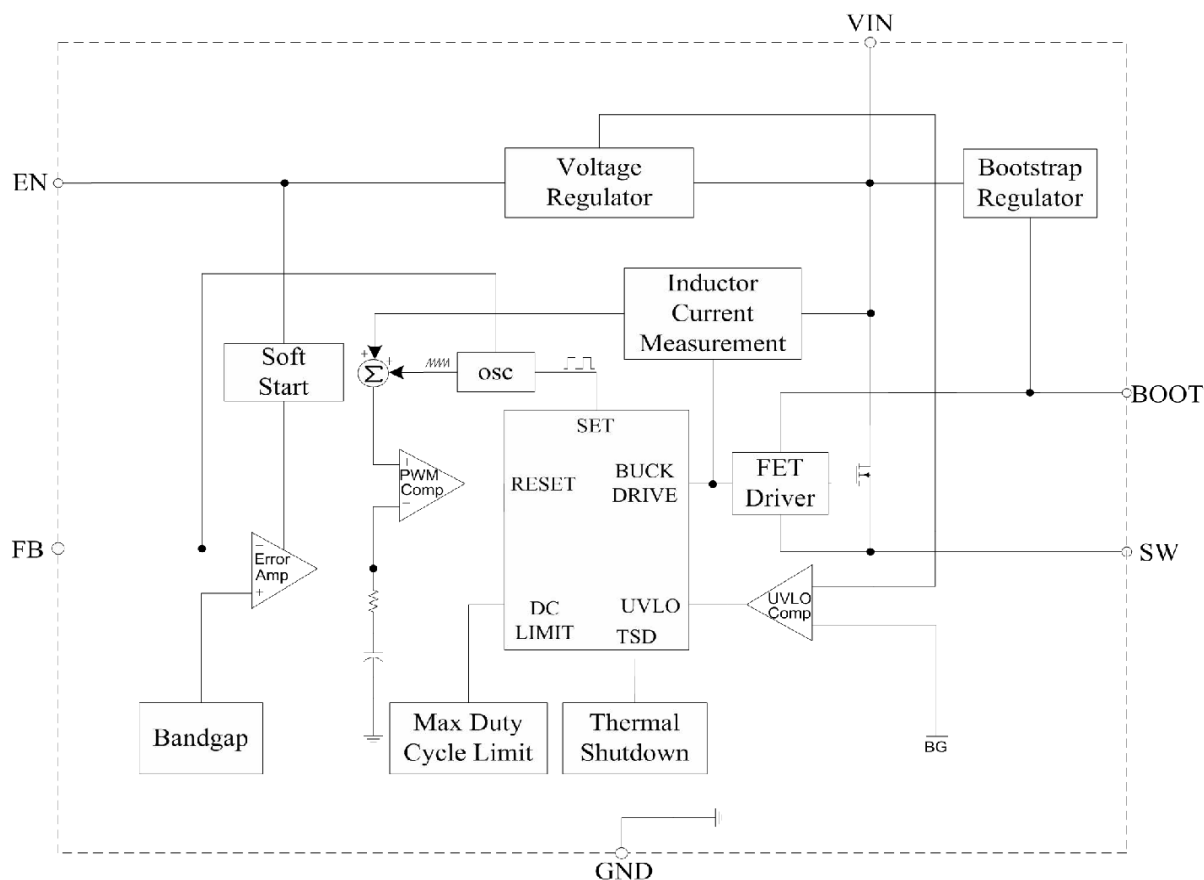

Absolute Maximum Ratings

| Item | Description | Range | Unit |
|--------------------------|---|----------------------------|------|
| V_{SW}, V_{EN}, V_{IN} | SW, EN, VIN Voltage | -0.3 ~ +120 | V |
| V_{FB} | FB Voltage | -0.3 ~ +7 | V |
| V_{BOOT} | BOOT Voltage | $V_{SW}-0.3 \sim V_{SW}+7$ | V |
| T_{stg} | Storage Junction Temperature | -55 ~ 150 | °C |
| T_{solder} | Lead Temperature (Soldering 10 sec.) | 260°C | |
| ESD | Human Body Model | 2 | kV |

Note: exceeding the range specified by the rated parameters will cause damage to the chip, and the working state of the chip beyond the range of rated parameters cannot be guaranteed. Exposure outside the rated parameter range will affect the reliability of the chip.

Electrical Characteristics

(At $T_A=25^{\circ}\text{C}$, $V_{IN}=48\text{V}$, $V_{OUT}=12\text{V}$, Unless Otherwise Noted)

| Parameter | Symbol | Test Conditions | Min | Typ | Max | Unit |
|-------------------------------------|------------------|------------------------|-----|------|-----|--------------------|
| VCC SUPPLY VOLTAGE | | | | | | |
| Input Voltage | V_{IN} | | 9 | - | 100 | V |
| UVLO | V_{STRAT} | | - | 8 | - | V |
| UVLO Hysteresis | V_{UVLO1} | | - | 0.3 | - | V |
| Shutdown supply current | I_{SHUT} | EN=0V | - | 9 | - | uA |
| Input Quiescent Current | I_Q | $V_{FB}=1\text{V}$ | - | 500 | - | uA |
| ENABLE | | | | | | |
| Enable threshold voltage | V_{EN} | | - | 2.2 | - | V |
| Enable threshold voltage Hysteresis | V_{UVLO2} | | - | 0.2 | - | V |
| FEEDBACK | | | | | | |
| FB Reference Threshold | V_{FB} | | - | 0.8 | - | V |
| Feedback short voltage | $V_{FB (short)}$ | | - | 0.35 | - | V |
| Feedback short voltage Hysteresis | V_{FB2} | | - | 0.42 | - | V |
| OSCILLATOR | | | | | | |
| Switching frequency | F | $I_{OUT}=500\text{mA}$ | - | 150 | - | kHz |
| Maximum Duty Cycle | D_{MAX} | $V_{IN}=12\text{V}$ | - | 92 | - | % |
| CURRENT LIMIT | | | | | | |
| Current Limit Threshold | I_{PEAK} | | - | 1.5 | - | A |
| HIGH-SIDE MOSFET | | | | | | |
| On-resistance | $R_{DS(on)}$ | $V_{IN}=18\text{V}$ | - | 400 | - | m Ω |
| THERMAL SHUTDOWN | | | | | | |
| Thermal shutdown Temp | T_{SD} | | - | 150 | - | $^{\circ}\text{C}$ |
| Thermal shutdown Temp Hysteresis | T_{SH} | | - | 30 | - | $^{\circ}\text{C}$ |

Typical Characteristics (At $T_A=25^\circ\text{C}$, $V_{IN}=48\text{V}$, $V_{OUT}=12\text{V}$, Unless Otherwise Noted)

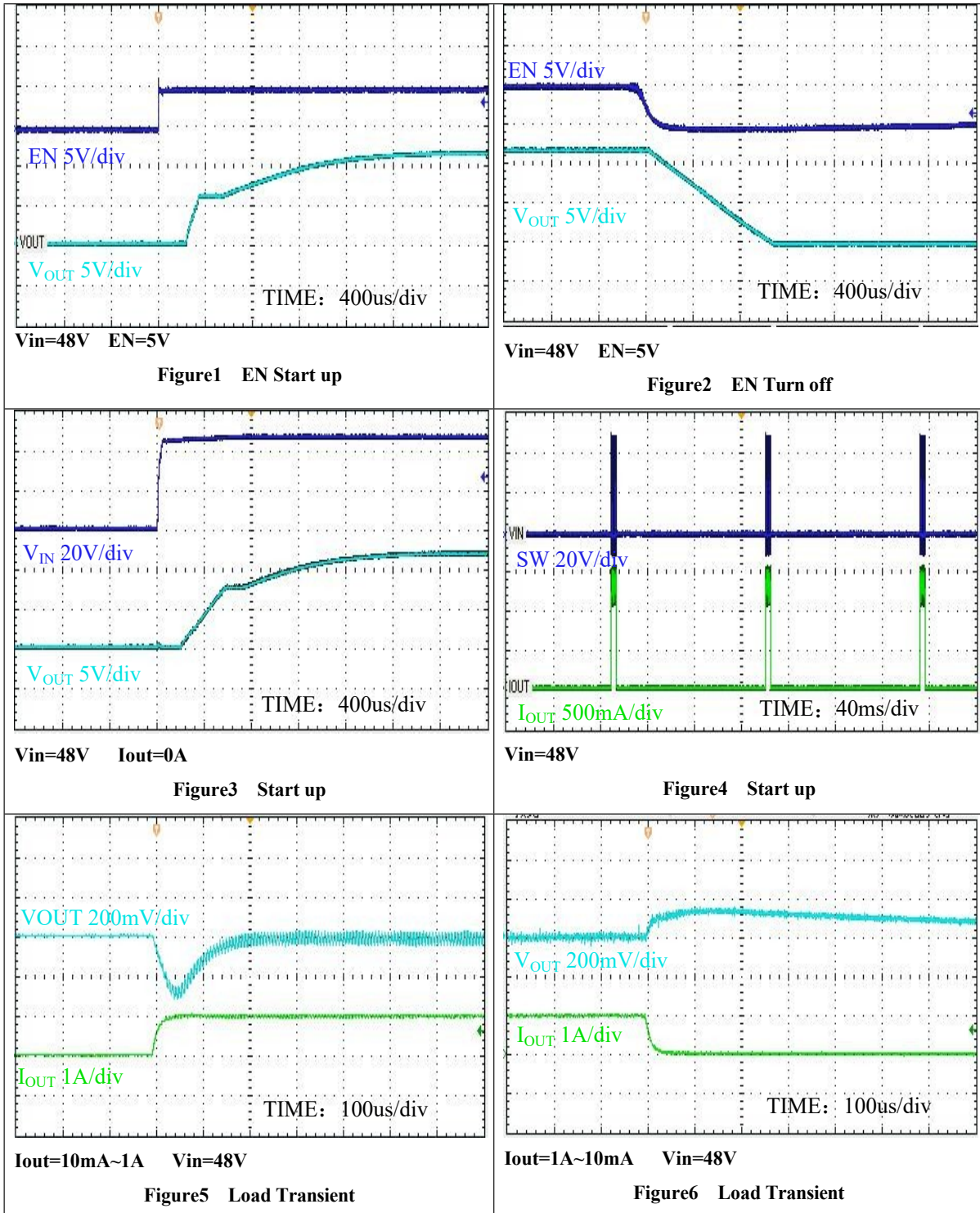

Applications Information

Over-current Protection: The HT1015A implements current-mode control which uses the internal COMP voltage to control the turn on and the turnoff of the high-side MOSFET on a cycle-by-cycle basis. During each cycle, the switch current and the current reference generated by the internal COMP voltage are compared. When the peak switch current intersects the current reference the high-side switch turns off.

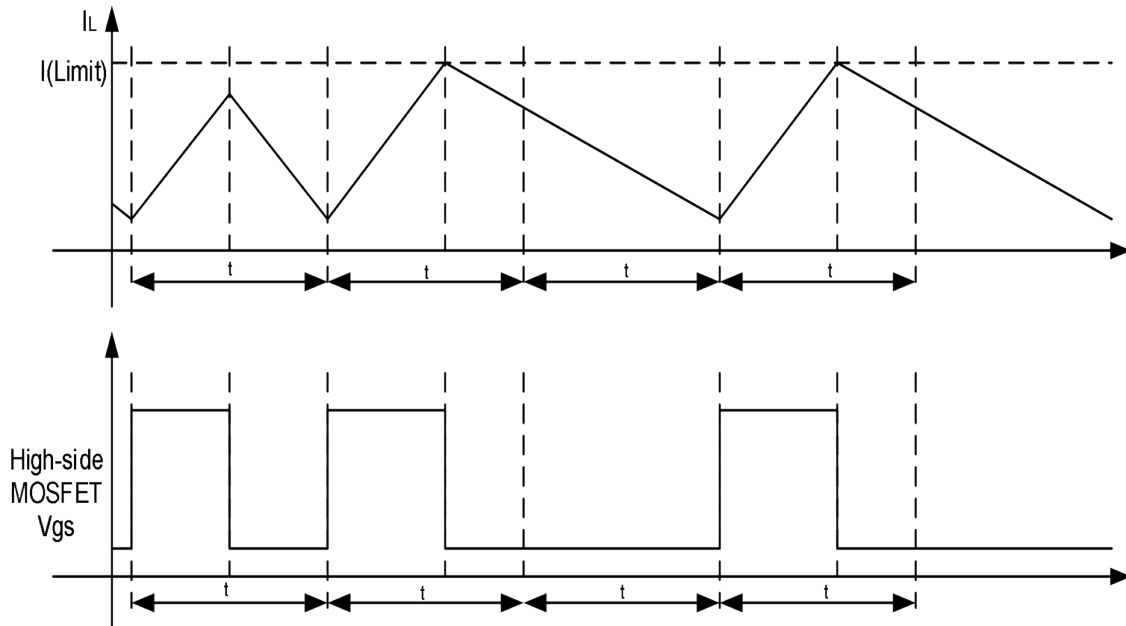

Hiccup mode: If an output overload condition occurs for more than the hiccup wait time, which is programmed for 512 switching cycles (T_1), the device shuts down and restarts after the hiccup time of 16384 cycles (T_2). The hiccup mode helps to reduce the device power dissipation under severe over-current conditions.

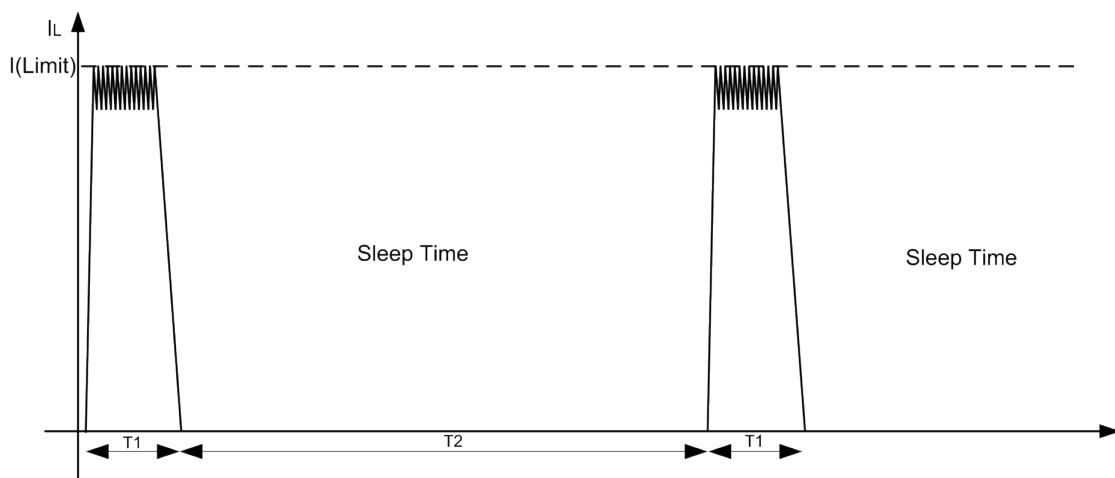

C1: This capacitor's purpose is to supply most of the switch current during the on-time, and limit the voltage ripple at VIN. To allow for the capacitor's tolerance, temperature effects, and voltage effects, a 47 μF , capacitor is used.

C2: This capacitor helps avoid supply voltage transients and ringing due to long lead inductance at VIN. A low ESR, 1 μF ceramic chip capacitor is recommended, located close to the HT1015A.

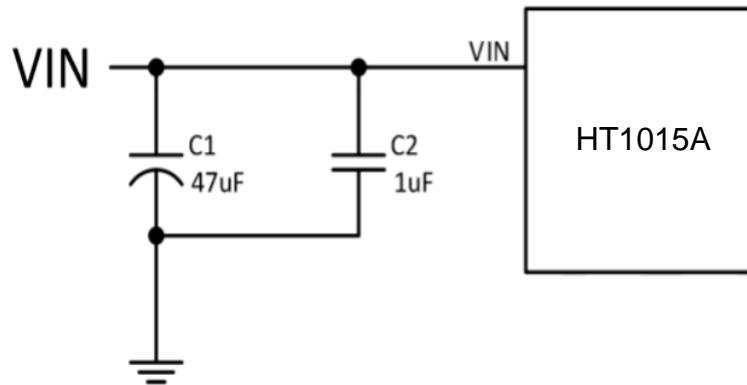

Figure7 The capacitor on the VIN

L1: The inductance is determined based on the switching frequency, load current, inductor ripple current, and the minimum and maximum input voltages designated VIN(min) and VIN(max), respectively. The peak inductor current during an overload condition is limited to 3 A nominal. Use the value of 68 μH , 5A to prevent saturation.

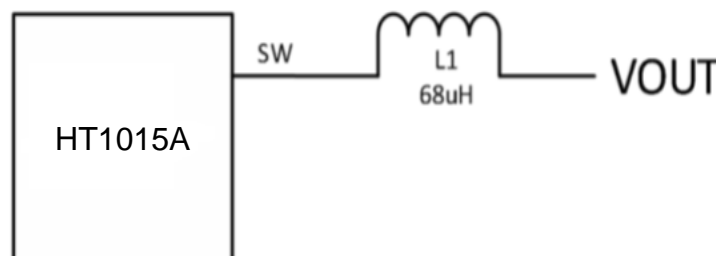

Figure8 The inductor on the choice

D1:A power Schottky diode is recommended. Ultra-fast recovery diodes are not recommended as the high speed transitions at the SW pin may inadvertently affect the IC's operation through external or internal EMI. The important parameters are reverse recovery time and forward voltage. The reverse recovery time determines how long the reverse current surge lasts with each turn-on of the internal buck switch. The forward voltage drop affects efficiency. The diode's reverse voltage rating must be at least as great as the maximum input voltage, plus ripple and transients, and its current rating must be at least as great as the maximum current limit specification.

C4/C5:The output capacitor filters the inductor ripple current and provides a source of charge for transient load conditions. The best performance is typically obtained using ceramic or polymer electrolytic type components. Typical tradeoffs are that the ceramic capacitor provides extremely low ESR to reduce the output ripple voltage and noise spikes. In order to meet output ripple specification, we should choose a ceramic capacitor of 22uF and a polymer electrolytic capacitor of 100uF.

R1/R2:The output voltage (VOUT) is programmed by two external resistors as shown in the Figure15. The regulation point can be calculated as follows:

$$V_{OUT} = 0.8 \times (R1 + R2) / R2$$

Figure9 Output Capacitors and Output Configuration

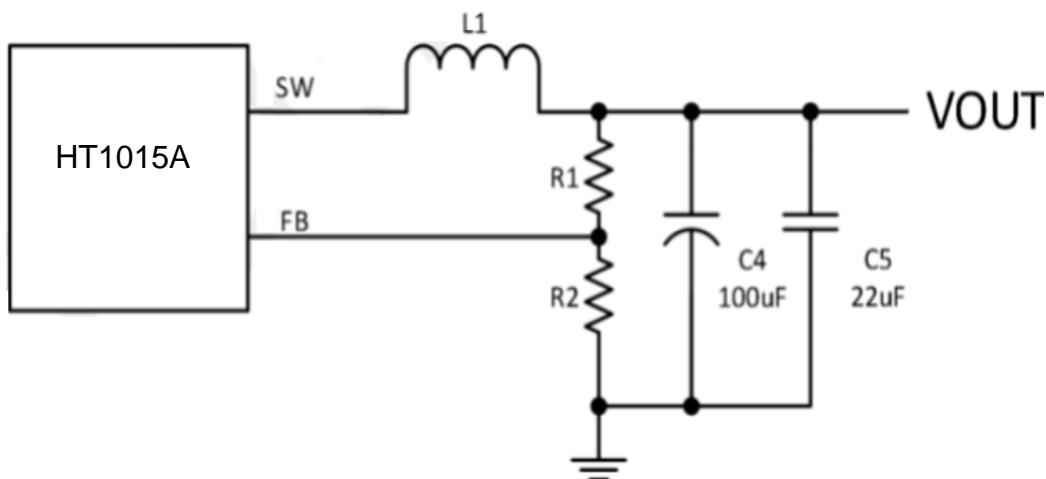

Layout

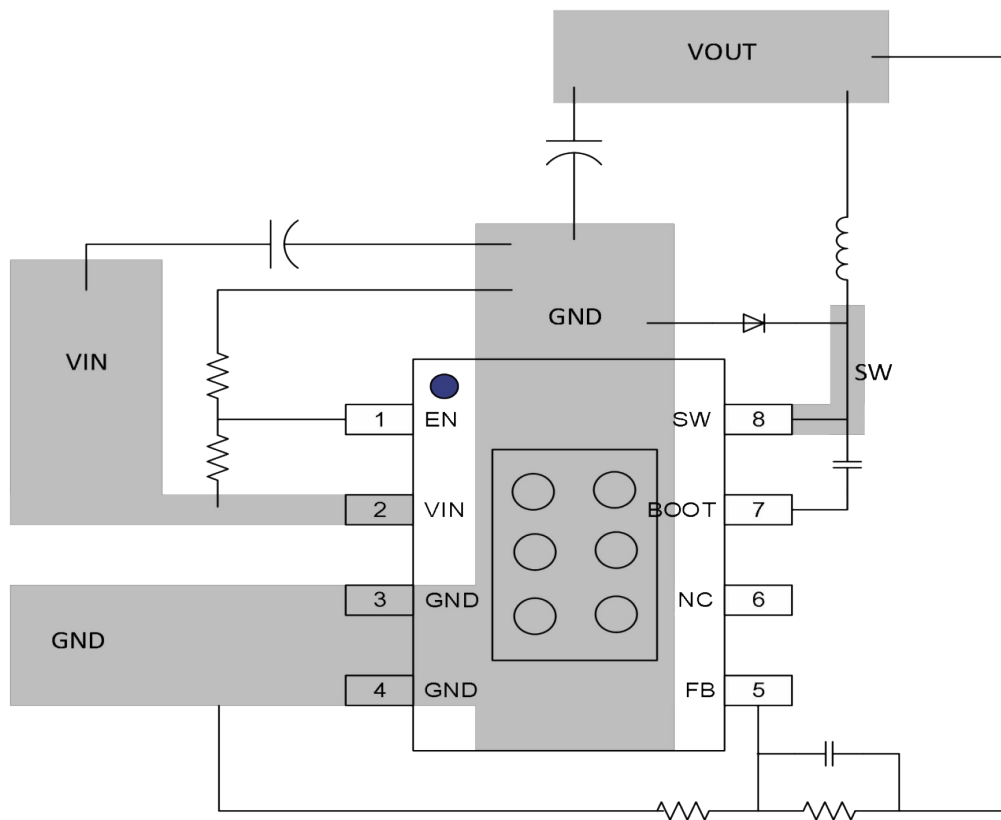

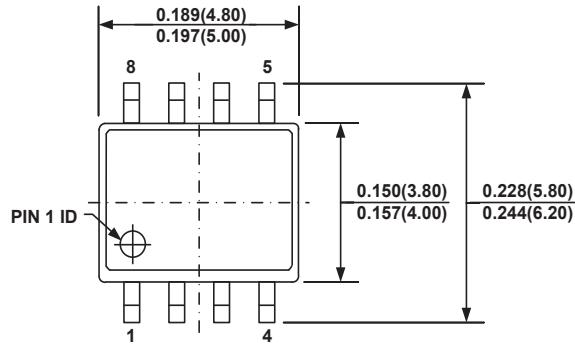
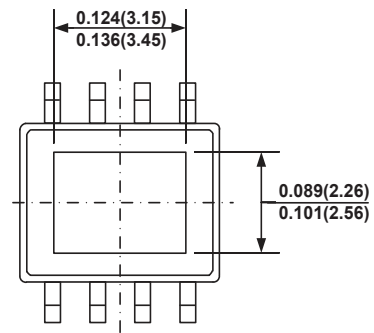
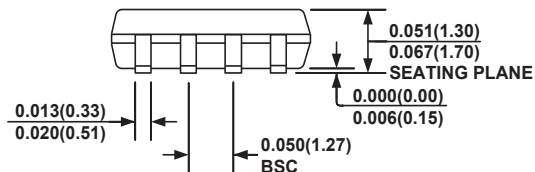
PACKAGE INFORMATION
SOIC8E (EXPOSED PAD)

TOP VIEW

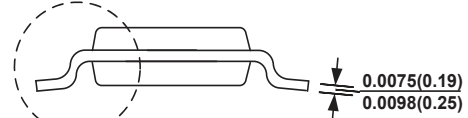
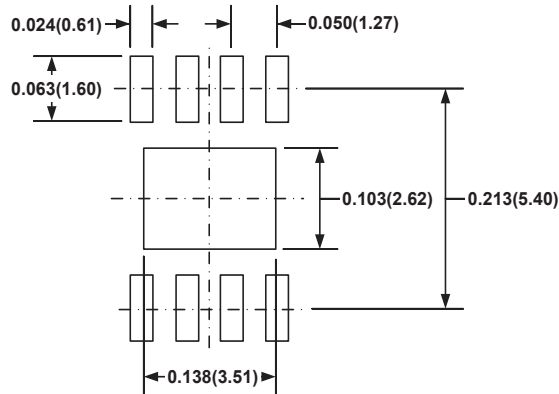
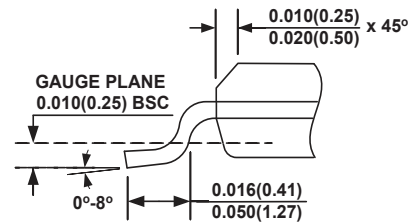
BOTTOM VIEW

FRONT VIEW

SEE DETAIL "A"

SIDE VIEW

RECOMMENDED LAND PATTERN

DETAIL "A"
NOTE:

- 1) CONTROL DIMENSION IS IN INCHES. DIMENSION IN BRACKET IS IN MILLIMETERS.
- 2) PACKAGE LENGTH DOES NOT INCLUDE MOLD FLASH, PROTRUSIONS OR GATE BURRS.
- 3) PACKAGE WIDTH DOES NOT INCLUDE INTERLEAD FLASH OR PROTRUSIONS.
- 4) LEAD COPLANARITY (BOTTOM OF LEADS AFTER FORMING) SHALL BE 0.004" INCHES MAX.
- 5) DRAWING CONFORMS TO JEDEC MS-012, VARIATION BA.
- 6) DRAWING IS NOT TO SCALE.