

Features

- High Blocking Voltage with Low On-Resistance
- High Speed Switching with Low Capacitances
- Easy to Parallel and Simple to Drive
- Avalanche Ruggedness
- Halogen Free, RoHS Compliant

Benefits

- Higher System Efficiency
- Reduced Cooling Requirements
- Increased Power Density
- Increased System Switching Frequency

Applications

- Solar Inverters
- Switch Mode Power Supplies
- High Voltage DC/DC Converters
- Battery Chargers
- Motor Drives
- Pulsed Power applications

Package

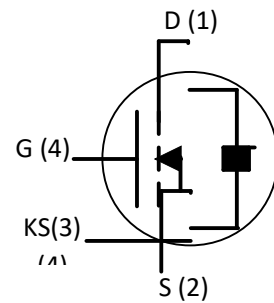

Maximum Ratings ($T_c = 25^\circ\text{C}$ unless otherwise specified)

Symbol	Parameter	Value	Unit	Test Conditions	Note
V_{DSmax}	Drain - Source Voltage	1200	V	$V_{GS} = 0\text{ V}, I_D = 100\ \mu\text{A}$	
V_{GSmax}	Gate - Source Voltage	-10/+25	V	Absolute maximum values	
V_{GSop}	Gate - Source Voltage	-5/+20	V	Recommended operational values	
I_D	Continuous Drain Current	60	A	$V_{GS} = 20\text{ V}, T_C = 25^\circ\text{C}$	Fig. 19
		40		$V_{GS} = 20\text{ V}, T_C = 100^\circ\text{C}$	
$I_{D(pulse)}$	Pulsed Drain Current	160	A	Pulse width t_p limited by T_{jmax}	Fig. 22
P_D	Power Dissipation	330	W	$T_c = 25^\circ\text{C}, T_J = 150^\circ\text{C}$	Fig. 20
T_J, T_{stg}	Operating Junction and Storage Temperature	-55 to +175	$^\circ\text{C}$		
T_L	Solder Temperature	260	$^\circ\text{C}$	1.6mm (0.063") from case for 10s	
M_d	Mounting Torque	1 8.8	Nm lbf-in	M3 or 6-32 screw	

Electrical Characteristics

Symbol	Parameter	Min.	Typ.	Max.	Unit	Test Conditions	Note
$V_{(BR)DSS}$	Drain-Source Breakdown Voltage	1200			V	$V_{GS}=0V, I_D=100\mu A$	
$V_{GS(th)}$	Gate Threshold Voltage	2.0	2.50	4.0	V	$V_{GS}=V_{DS}, I_{DS}=10mA, T_C=25^\circ C$	Fig. 6
			1.80			$V_{GS}=V_{DS}, I_{DS}=10mA, T_C=150^\circ C$	
I_{DSS}	Zero Gate Voltage Drain Current		1	100	μA	$V_{DS}=1200V, V_{GS}=0V$	
I_{GSS}	Gate-Source Leakage Current			200	nA	$V_{GS}=20V, V_{DS}=0V$	
$R_{DS(on)}$	Drain-Source on-state Resistance		45	55	m Ω	$V_{GS}=20V, I_D=40A, T_C=25^\circ C$	Fig. 4
			58		m Ω	$V_{GS}=20V, I_D=40A, T_C=150^\circ C$	
g_{fs}	Transconductance		14.1		S	$V_{GS}=20V, I_D=40A, T_J=25^\circ C$	Fig. 5
			12.5		S	$V_{GS}=20V, I_D=40A, T_J=150^\circ C$	
C_{iss}	Input Capacitance		3550		pF	$V_{GS}=0V, V_{DS}=1000V, f=1MHz, V_{AC}=25mV$	Fig. 9
C_{oss}	Output Capacitance		162				
C_{rss}	Reverse Transfer Capacitance		29				
E_{ON}	Turn-On Switching Energy		1.5		mJ	$V_{DS}=800V, V_{GS}=-5/20V, I_D=40A, R_{G(ext)}=5\Omega, L=80\mu H$	
E_{OFF}	Turn-Off Switching Energy		0.7				
$t_{d(on)}$	Turn-On Delay Time		60		ns	$V_{DD}=800V, V_{GS}=-5/20V, I_D=40A, R_{G(ext)}=5\Omega, R_L=20\Omega, \text{Timing relative to } V_{DS}$	
t_r	Rise Time		140				
$t_{d(off)}$	Turn-Off Delay Time		50				
t_f	Fall Time		42				
$R_{G(int)}$	Internal Gate Resistance		1.0		Ω	$f=1MHz, V_{AC}=25mV$	
Q_{gs}	Gate to Source Charge		40		nC	$V_{DD}=800V, V_{GS}=-5/20V, I_D=40A$	Fig. 10
Q_{gd}	Gate to Drain Charge		55				
Q_g	Total Gate Charge		160				

Reverse Diode Characteristics

Symbol	Parameter	Typ.	Max.	Unit	Test Conditions	Note
V_{SD}	Diode Forward Voltage	3.6		V	$V_{GS}=-5V, I_{SD}=20A, T_J=25^\circ C$	Fig. 7
		3.3		V	$V_{GS}=-5V, I_{SD}=20A, T_J=150^\circ C$	Fig. 8
I_S	Continuous Diode Forward Current		20	A	$T_C=25^\circ C$	

Thermal Characteristics

Symbol	Parameter	Typ.	Unit	Test Conditions	Note
$R_{\theta JC}$	Thermal Resistance from Junction to Case	0.40	$^\circ C/W$		Fig. 12
$R_{\theta JA}$	Thermal Resistance From Junction to Ambient	38			

Typical Performance

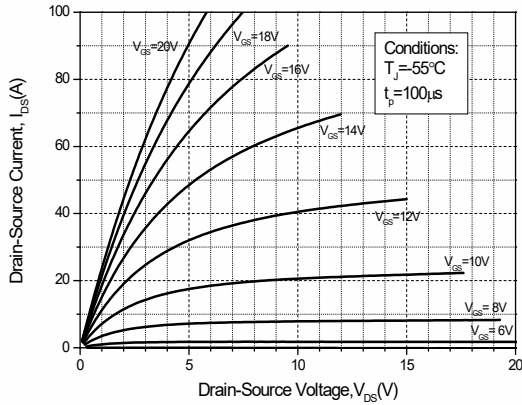

Figure 1. Output Characteristics $T_J = -55^\circ\text{C}$

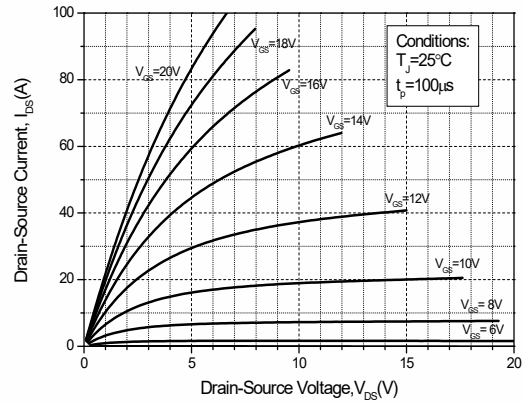

Figure 2. Output Characteristics $T_J = 25^\circ\text{C}$

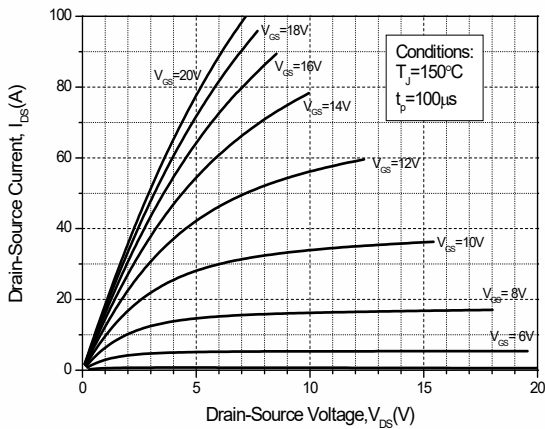

Figure 3. Output Characteristics $T_J = 150^\circ\text{C}$

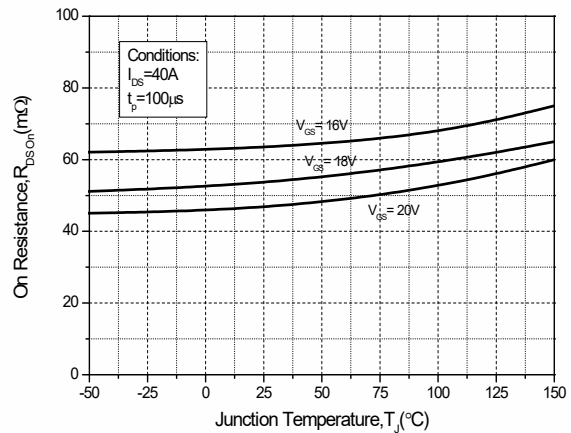

Figure 4. On-Resistance For Various Gate Voltage

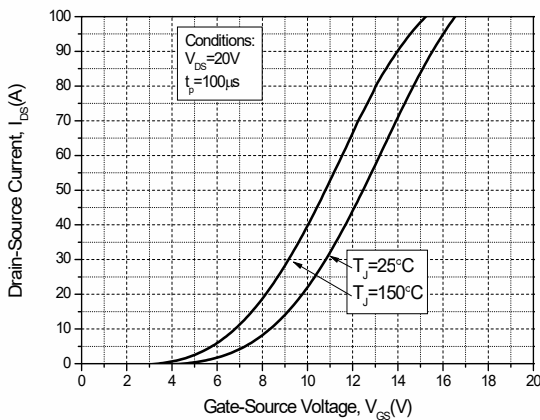

Figure 5. Transfer Characteristic for Various Junction Temperatures

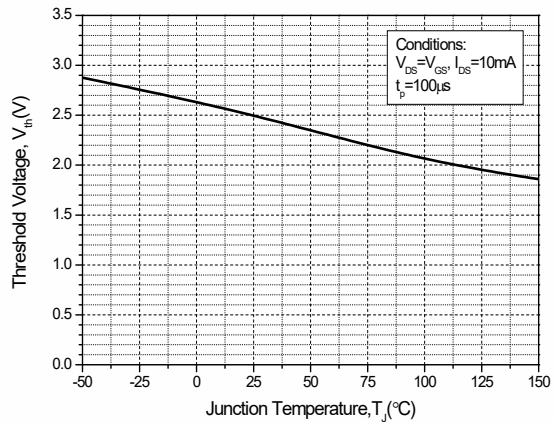

Figure 6. Threshold Voltage vs. Temperature

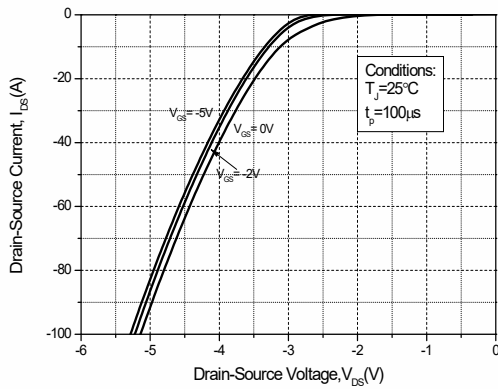

Figure 7. Body Diode Characteristics

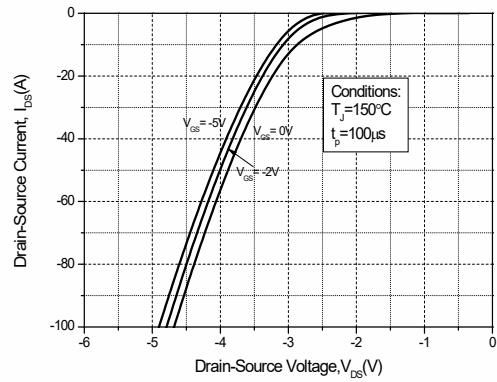

Figure 8. Body Diode Characteristics

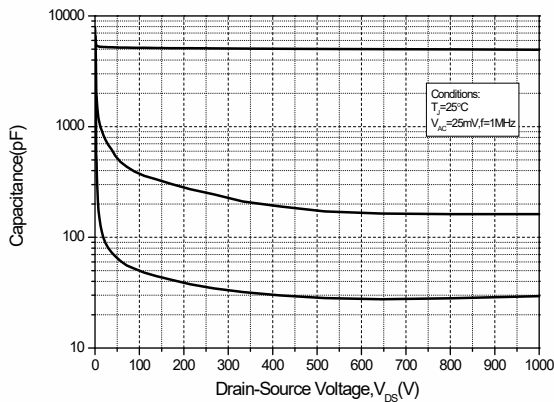

Figure 9. Capacitances vs. Drain-Source Voltage

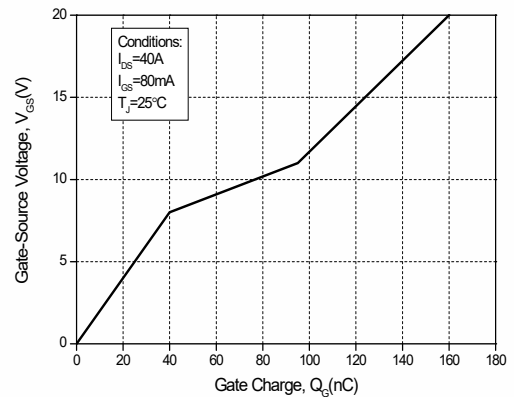

Figure 10. Gate Charge Characteristics

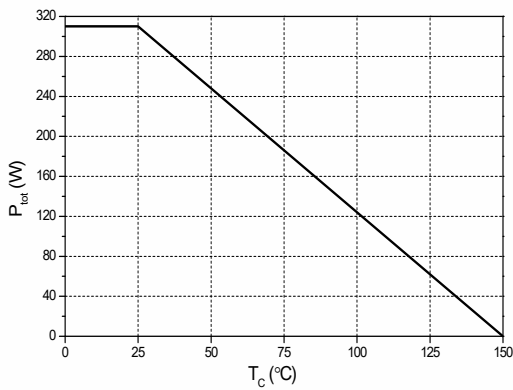

Figure 11. Power Dissipation Derating

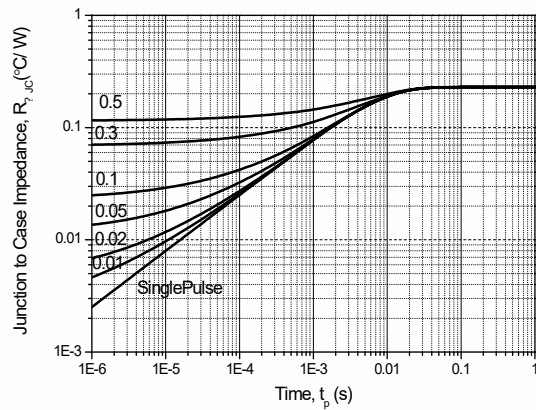
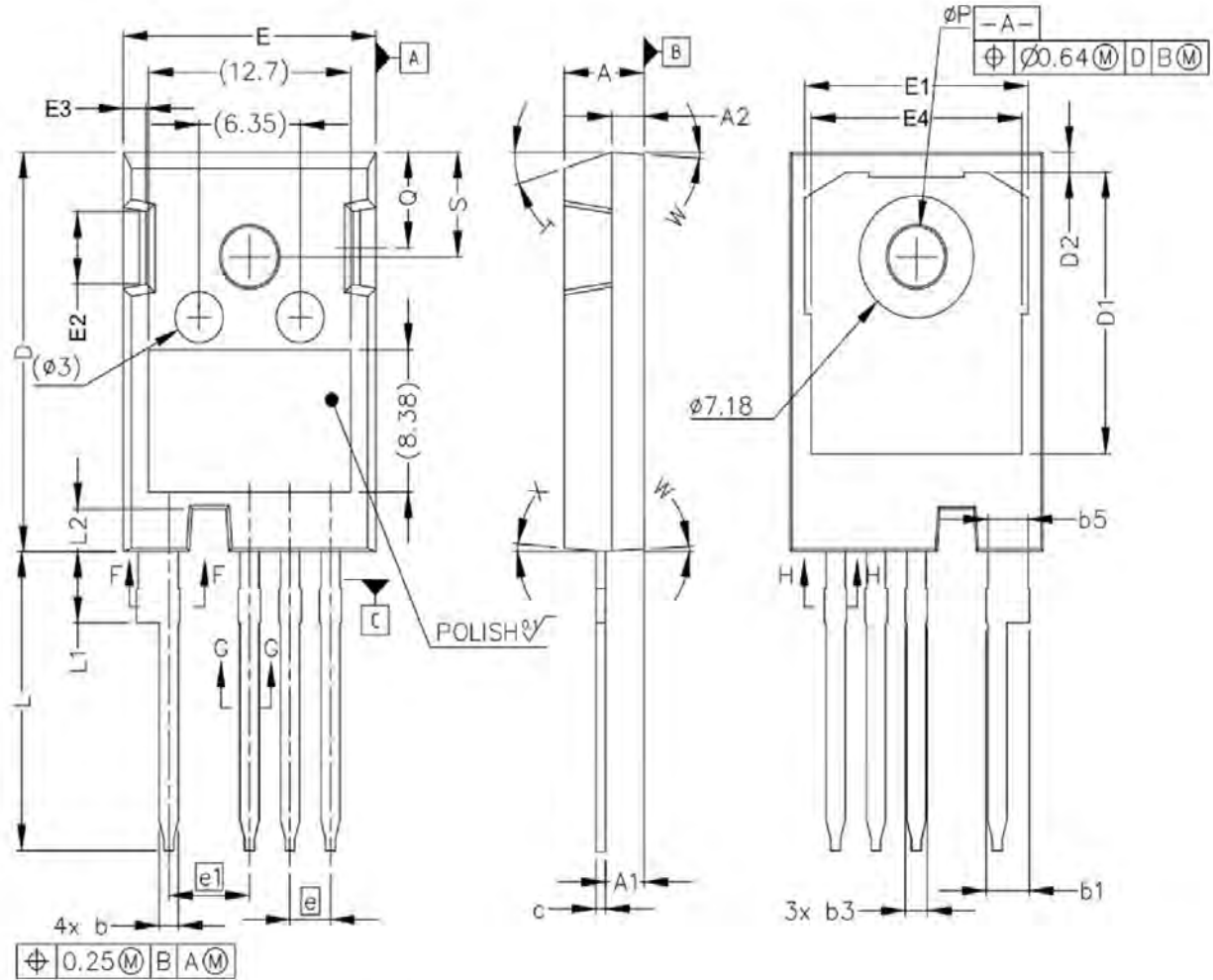

Figure 12. Transient Thermal Impedance

Package Dimensions: TO-247-4L



SYMBOL	Mechanical Dimensions/mm			SYMBOL	Mechanical Dimensions/mm			SYMBOL	Mechanical Dimensions/mm		
	MIN	NOM	MAX						MIN	NOM	MAX
A	4.83	5.00	5.21	D	23.30	23.45	23.60	L1	3.97	4.13	4.37
A1	2.29	2.41	2.54	D1	16.25	16.55	17.65	ϕ P	3.51	3.6	3.65
A2	1.91	2.00	2.16	E	15.75	15.90	16.13	W	-	3.5	-
b	1.07	1.20	1.33	E1	13.10	13.65	14.15	X	-	4	-
b1	2.39	2.60	2.94	E2	3.68	5.0	5.1	Q	5.49	5.8	6.0
b2	2.39	-	2.84	e	2.54			S	6.04	6.15	6.30
c	0.55	0.60	0.68	L	17.31	17.45	17.82	T	-	17.5	-

NOTE:
 1.The plastic package is not marked as smooth surfaceRa=0.1;Subglossy surfaceRa=0.8
 2.Undeclared tolerance ± 0.15 , Unmarked filletRmax=0.25

NAME	TO-247-4L OUTLINE	UNIT	mm	DESIGNED	Shawn	THIRD ANGLE SYSTEM
DWGNO		PAGE	1 OF 1	CHECKED		
VERSION	Ver1.0	ISSUE DATE		APPROVED		