

修 订	标 记	修 改 描 述	签 名	日 期
REV	MARK	REVISION DESCRIPTION	SIGNATURE	DATE
AO		NEW DWG		2016-03-12

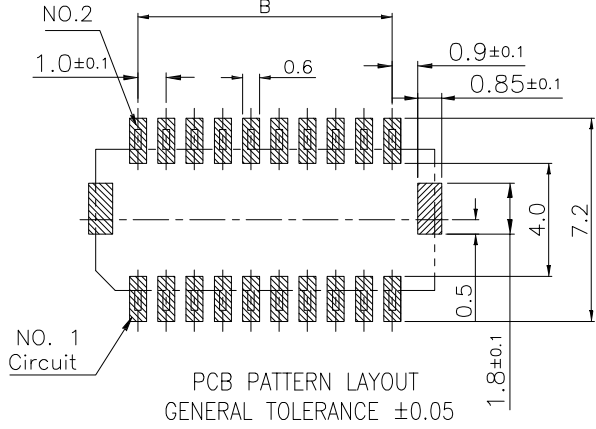

PCB PATTERN LAYOUT
GENERAL TOLERANCE ±0.05

- NOTES:
- MATERIAL:
 - HOUSING: HALOGEN FREE THERMOPLASTIC, HIGH TEMP.UL94V-0; COLOR:NATURAL.
 - CONTACT: COPPER ALLOY
 - FITTING NAIL: COPPER ALLOY
 - FINISH:
 - CONTACT & SOLDER:
 - 50~100u" NICKEL UNDER PLATING OVERALL
 - 3u" GOLD PLATING ON CONTACT
 - 80~150u" PURE-TIN PLATING OVERALL
 - GOLD FLASH ON CONTACT AND 80~150u"(MIN) MATT-TIN PLATING OVERALL
 - 15u" GOLD ON CONTACT AND 80~150u"(MIN) MATT-TIN PLATING OVERALL
 - FITTING NAIL:
 - 50~100u" NICKEL UNDER PLATING OVERALL
 - 80~150u" MATT TIN PLATING OVERALL
 - REFLOW SOLDER CAPABLE TO 260°C PER
 - Working voltage less than 36 volts (per pin)
 - Voltage: 50 Volts AC (per pin)
 - HOUSING: NY9T

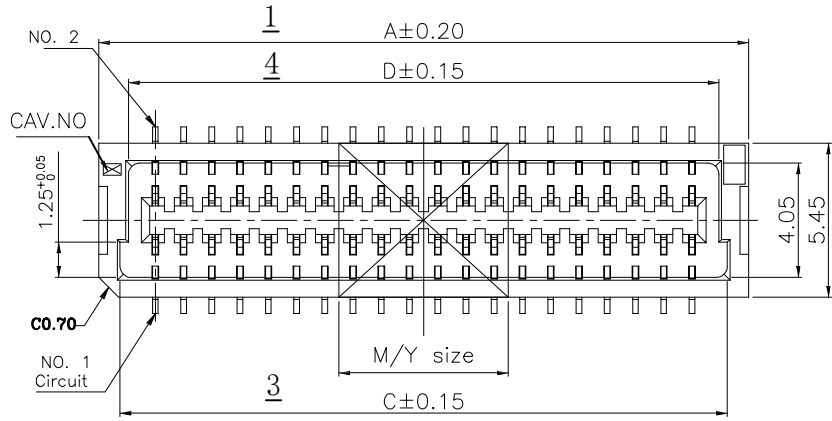
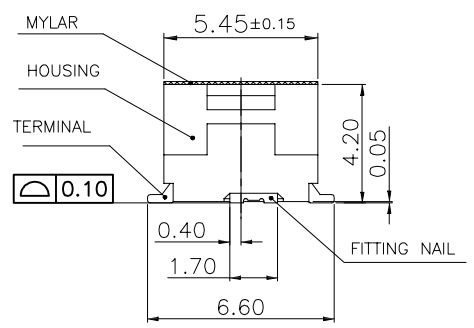
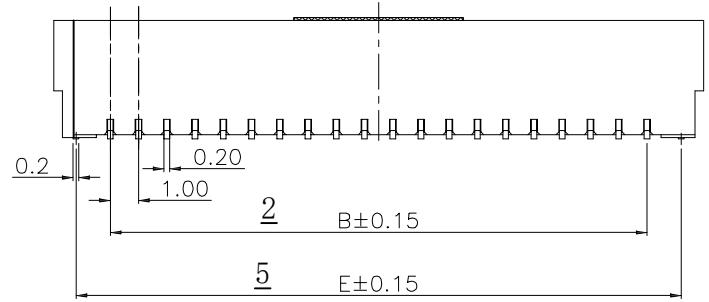

CKT	DIMA	DIMB	DIMC	DIMD	DIME
2*3	6.0	2.0	4.5	3.8	4.43
2*4	7.0	3.0	5.5	4.8	5.43
2*5	8.0	4.0	6.5	5.8	6.43
2*6	9.0	5.0	7.5	6.8	7.43
2*7	10.0	6.0	8.5	7.8	8.43
2*8	11.0	7.0	9.5	8.8	9.43
2*9	12.0	8.0	10.5	9.8	10.43
2*10	13.0	9.0	11.5	10.8	11.43
2*11	14.0	10.0	12.5	11.8	12.43
2*12	15.0	11.0	13.5	12.8	13.43
2*15	18.0	14.0	16.5	15.8	16.43
2*20	23.0	19.0	21.5	20.8	21.43
2*25	28.0	24.0	26.5	25.8	26.43



深圳市华德共创科技有限公司
Shenzhen Huade co-create Technology Co.,LTD
电话: 0755-27111225 传真: 0755-29940187

-TOLERANCES- UNLESS OTHERWISE SPECIFIED 公差参数表		TITLE: 产品名称: SHLD1.0双排带扣立贴针座	
X.X ±0.30	X.X* ±3'	APPD: 核准:	PART NO: 产品编号: HDGC1006WV-S-2XnP
X.XX ±0.20	X.XX* ±2'	CHECK: 校对: 王建业	DATE SCALE UNIT CODE NUMBER
X.XXX ±0.10	X.XXX* ±1'	DRAW: 绘图: 黄艳兰	2016-03-12 1:1 mm A001