



FSV9532

Standard multi-protocol reader IC

Rev. 1.0 — 18 September 2017

Product data sheet

1. Introduction

This data sheet describes the functionality of the FSV9532 Integrated Circuit (IC). It includes the functional and electrical specifications and from a system and hardware viewpoint gives detailed information on how to design-in the device.

Remark: The FSV9532 supports all variants of the MIFARE Mini, MIFARE 1K, MIFARE 4K and MIFARE Ultralight RF identification protocols. To aid readability throughout this data sheet, the MIFARE Mini, MIFARE 1K, MIFARE 4K and MIFARE Ultralight products and protocols have the generic name MIFARE.

2. General description

The FSV9532 is a highly integrated reader IC for contactless communication at 13.56 MHz. The FSV9532 reader IC provides:

- outstanding modulation and demodulation for passive contactless communication
- a wide range of methods and protocols
- a small, fully integrated package
- pin compatibility with the FSV9505, FSV9530, FSV9531 and FSV9504

All protocol layers of the ISO/IEC 14443 A and ISO/IEC 14443 B communication standards are supported provided:

- additional components, such as the oscillator, power supply, coil etc. are correctly applied.
- standardized protocols, such as ISO/IEC 14443-4 and/or ISO/IEC 14443 B anticollision are correctly implemented

The FSV9532 supports contactless communication using MIFARE higher baud rates (see [Section 9.12 on page 40](#)). The receiver module provides a robust and efficient demodulation/decoding circuitry implementation for compatible transponder signals (see [Section 9.10 on page 34](#)).

The digital module, manages the complete ISO/IEC 14443 standard framing and error detection (parity and CRC). In addition, it supports the fast MIFARE security algorithm for authenticating the MIFARE products (see [Section 9.14 on page 42](#)).

All layers of the I-CODE1 and ISO/IEC 15693 protocols are supported by the FSV9532. The receiver module provides a robust and efficient demodulation/decoding circuitry implementation for I-CODE1 and ISO/IEC 15693 compatible transponder signals. The digital module handles I-CODE1 and ISO/IEC 15693 framing and error detection (CRC).



The internal transmitter module ([Section 9.9 on page 31](#)) can directly drive an antenna designed for a proximity operating distance up to 100 mm without any additional active circuitry.

A parallel interface can be directly connected to any 8-bit microprocessor to ensure reader/terminal design flexibility. In addition, Serial Peripheral Interface (SPI) compatibility is supported (see [Section 9.1.4 on page 9](#)).

3. Features and benefits

3.1 General

- Highly integrated analog circuitry for demodulating and decoding card/label response
- Buffered output drivers enable antenna connection using the minimum of external components
- Proximity operating distance up to 100 mm
- Supports both ISO/IEC 14443 A and ISO/IEC 14443 B standards
- Supports MIFARE dual-interface card ICs and the MIFARE Mini, MIFARE 1K, MIFARE 4K protocols
- Contactless communication at MIFARE higher baud rates (up to 424 kBd)
- Supports both I-CODE1 and ISO/IEC 15693 protocols
- Crypto1 and secure non-volatile internal key memory
- Compatible with the CLRC632
- Parallel microprocessor interface with internal address latch and IRQ line
- SPI compatibility
- Flexible interrupt handling
- Automatic detection of parallel microprocessor interface type
- 64-byte send and receive FIFO buffer
- Hard reset with low power function
- Software controlled Power-down mode
- Programmable timer
- Unique serial number
- User programmable start-up configuration
- Bit-oriented and byte oriented framing
- Independent power supply pins for analog, digital and transmitter modules
- Internal oscillator buffer optimized for low phase jitter enables 13.56 MHz quartz connection
- Clock frequency filtering
- 3.3 V to 5 V operation for transmitter in short range and proximity applications
- 3.3 V or 5 V operation for the digital module

4. Applications

- Electronic payment systems
- Identification systems
- Access control systems



- Subscriber services
- Banking systems
- Digital content systems

5. Quick reference data

Table 1. Quick reference data

Symbol	Parameter	Conditions	Min	Typ	Max	Unit
T _{amb}	ambient temperature		-40	-	+150	°C
T _{stg}	storage temperature		-40	-	+150	°C
V _{DDD}	digital supply voltage		-0.5	5	6	V
V _{DDA}	analog supply voltage		-0.5	5	6	V
V _{DD(TVDD)}	TVDD supply voltage		-0.5	5	6	V
V _i	input voltage (absolute value)	on any digital pin to DVSS	-0.5	-	V _{DDD} +	
		on pin RX to AVSS	-0.5	-	V _{DDA} +	
I _{LI}	input leakage current		-1.0	-	-1.0	mA
I _{DD(TVDD)}	TVDD supply current	continuous wave	-	-	150	mA

6. Ordering information

Table 2. Ordering information

Type number	Package		Version
	Name	Description	
FSV9532	SO3	plastic small outline package; 32 leads; body width 7.5 mm	SOT287-1



7. Block diagram

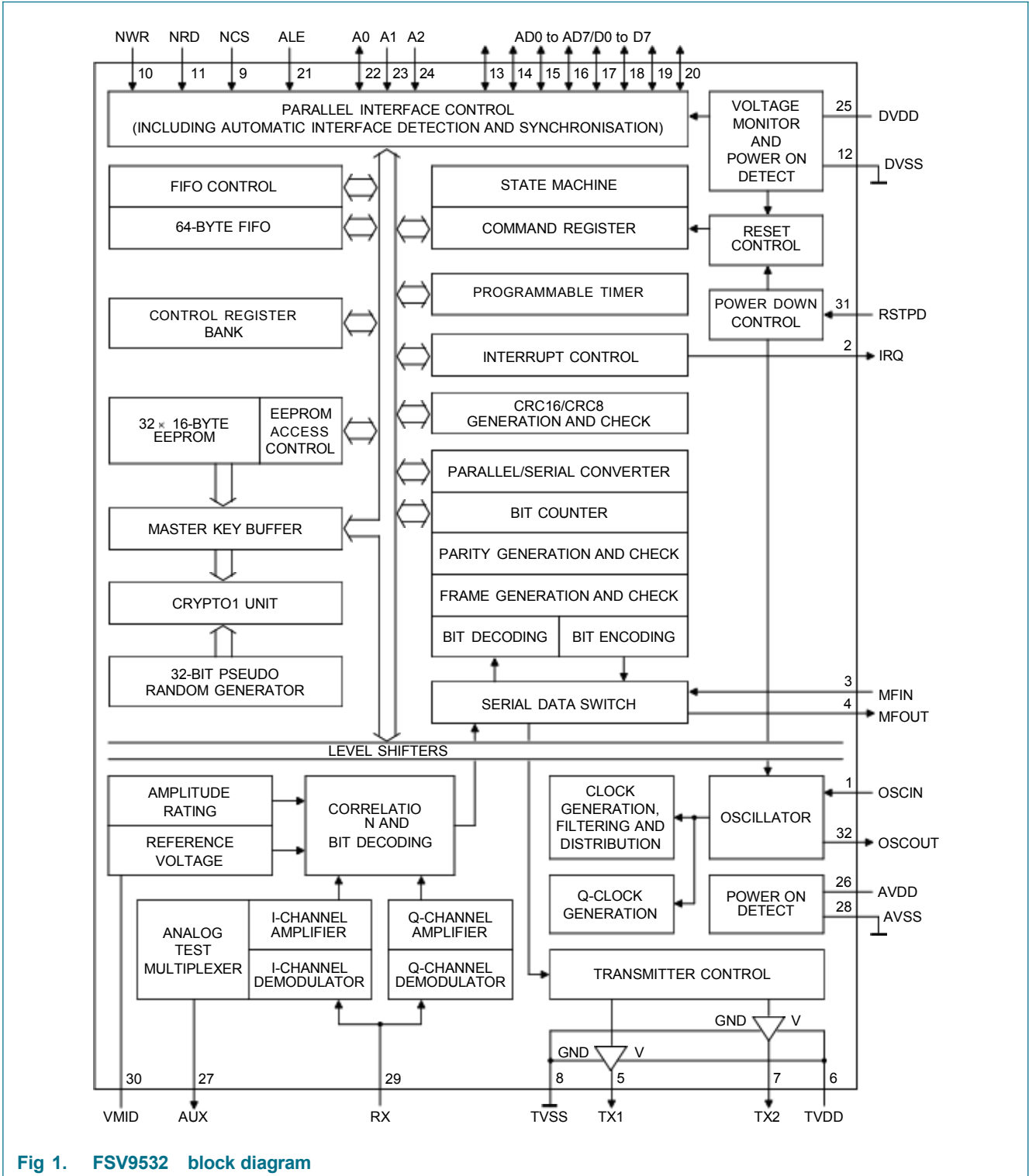

Fig 1. FSV9532 block diagram



8. Pinning information

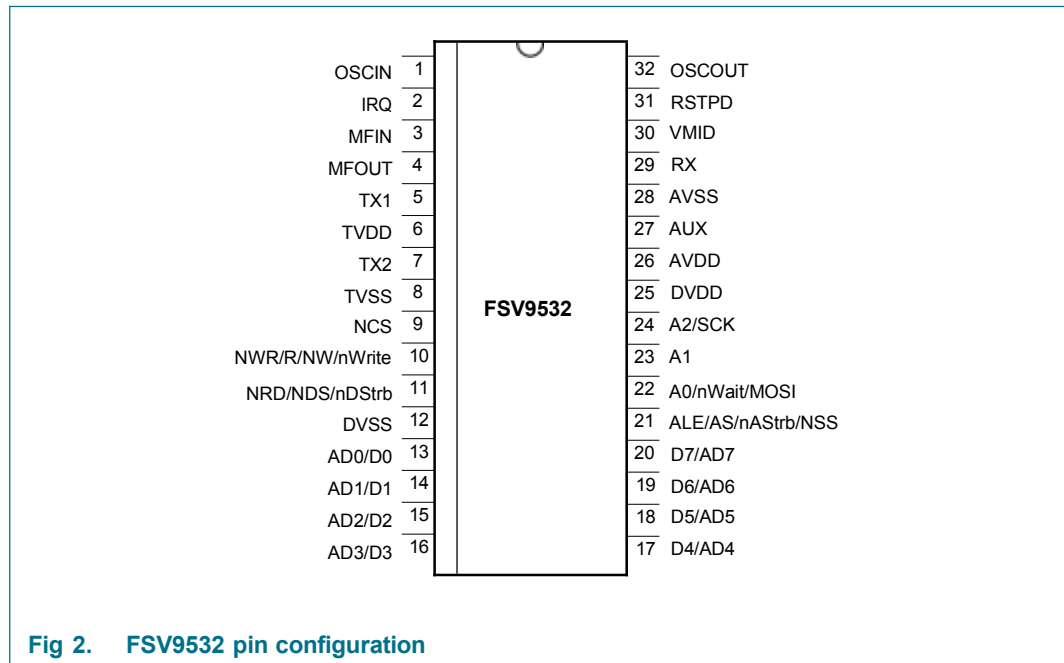

Fig 2. FSV9532 pin configuration

8.1 Pin description

Table 3. Pin description

Pin	Symbol	Type ^[1]	Description
1	OSCIN	I	oscillator/clock inputs: crystal oscillator input to the oscillator's inverting amplifier externally generated clock input; $f_{osc} = 13.56 \text{ MHz}$
2	IRQ	O	interrupt request generates an output signaling an interrupt event
3	MFIN	I	ISO/IEC 14443 A MIFARE serial data interface input
4 ^[2]	MFOU	O	interface outputs used as follows: MIFARE: generates serial data ISO/IEC 14443 A I-CODE: generates serial data based on I-CODE1 and ISO/IEC 15693
5	TX1	O	transmitter 1 modulated carrier output; 13.56 MHz
6	TVDD	P	transmitter power supply for the TX1 and TX2 output stages
7	TX2	O	transmitter 2 modulated carrier output; 13.56 MHz
8	TVSS	G	transmitter ground for the TX1 and TX2 output stages
9	NCS	I	not chip select input is used to select and activate the FSV9532's microprocessor interface
10 ^[3]	NWR	I	not write input generates the strobe signal for writing data to the FSV9532 registers when applied to pins D0 to D7
	R/NW	I	read not write input is used to switch between read or write cycles
	nWrite	I	not write input selects the read or write cycle to be performed



Table 3. Pin description

Pin	Symbol	Type ^[1]	Description
11 ^[3]	NRD	I	not read input generates the strobe signal for reading data from the FSV9532 registers when applied to pins D0 to D7
	NDS	I	not data strobe input generates the strobe signal for the read and write cycles
	nDStrb	I	not data strobe input generates the strobe signal for the read and write cycles
12	DVSS	G	digital ground
13	D0	O	SPI master in, slave out output
13 to 20 ^[3]	D0 to D7	I/O	8-bit bidirectional data bus input/output on pins D0 to D7
	AD0 to AD7	I/O	8-bit bidirectional address and data bus input/output on pins AD0 to AD7
21 ^[3]	ALE	I	address latch enable input for pins AD0 to AD5; HIGH latches the internal address
	AS	I	address strobe input for pins AD0 to AD5; HIGH latches the internal address
	nAStrb	I	not address strobe input for pins AD0 to AD5; LOW latches the internal address
	NSS	I	not slave select strobe input for SPI communication
22 ^[3]	A0	I	address line 0 is the address register bit 0 input
	nWait	O	not wait output: LOW starts an access cycle HIGH ends an access cycle
	MOSI	I	SPI master out, slave in
23	A1	I	address line 1 is the address register bit 1 input
24 ^[3]	A2	I	address line 2 is the address register bit 2 input
	SCK	I	SPI serial clock input
25	DVDD	P	digital power supply
26	AVDD	P	analog power supply for pins OSCIN, OSCOUT, RX, VMID and AUX
27	AUX	O	auxiliary output is used to generate analog test signals. The output signal is selected using the TestAnaSelect register's TestAnaOutSel[4:0] bits
28	AVSS	G	analog ground
29	RX	I	receiver input is used as the card response input. The carrier is load modulated at 13.56 MHz, drawn from the antenna circuit
30	VMID	P	internal reference voltage pin provides the internal reference voltage as a supply Remark: It must be connected to a 100 nF block capacitor connected between pin VMID and ground
31	RSTPD	I	reset and power-down input: HIGH: the internal current sinks are switched off, the oscillator is inhibited and the input pads are disconnected LOW (negative edge): start internal reset phase
32	OSCOUT	O	crystal oscillator output for the oscillator's inverting amplifier

[1] Pin types: I = Input, O = Output, I/O = Input/Output, P = Power and G = Ground.

[2] The FSV9504 uses pin name SIGOUT for pin MFOUT. The FSV9532 functionality includes test functions for the FSV9504 using pin MFOUT.

[3] These pins provide different functionality depending on the selected microprocessor interface type (see [Section 9.1 on page 7](#) for detailed information).



9. Functional description

9.1 Digital interface

9.1.1 Overview of supported microprocessor interfaces

The FSV9532 supports direct interfacing to various 8-bit microprocessors. Alternatively, the FSV9532 can be connected to a PC's Enhanced Parallel Port (EPP). [Table 4](#) shows the parallel interface signals supported by the FSV9532.

Table 4. Supported microprocessor and EPP interface signals

Bus control signals	Bus	Separated address and data bus	Multiplexed address and data bus
Separated read and write strobes	control	NRD, NWR, NCS	NRD, NWR, NCS, ALE
	address	A0, A1, A2	AD0, AD1, AD2, AD3, AD4, AD5
	data	D0 to D7	AD0 to AD7
Common read and write strobe	control	R/NW, NDS, NCS	R/NW, NDS, NCS, AS
	address	A0, A1, A2	AD0, AD1, AD2, AD3, AD4, AD5
	data	D0 to D7	AD0 to AD7
Common read and write strobe with handshake (EPP)	control	-	nWrite, nDStrb, nAStrb, nWait
	address	-	AD0, AD1, AD2, AD3, AD4, AD5
	data	-	AD0 to AD7

9.1.2 Automatic microprocessor interface detection

After a Power-On or Hard reset, the FSV9532 resets parallel microprocessor interface mode and detects the microprocessor interface type.

The FSV9532 identifies the microprocessor interface using the logic levels on the control pins. This is performed using a combination of fixed pin connections and the dedicated Initialization routine (see [Section 9.7.4 on page 30](#)).



9.1.3 Connection to different microprocessor types

The connection to various microprocessor types is shown in Table 5.

Table 5. Connection scheme for detecting the parallel interface type

FSV9532 pins	Parallel interface type and signals				
	Separated read/write strobe		Common read/write strobe		
	Dedicated address bus	Multiplexed address bus	Dedicated address bus	Multiplexed address bus	Multiplexed address bus with handshake
ALE	HIGH	ALE	HIGH	AS	nAStb
A2	A2	LOW	A2	LOW	HIGH
A1	A1	HIGH	A1	HIGH	HIGH
A0	A0	HIGH	A0	LOW	nWait
NRD	NRD	NRD	NDS	NDS	nDStb
NWR	NWR	NWR	R/NW	R/NW	nWrite
NCS	NCS	NCS	NCS	NCS	LOW
D7 to D0	D7 to D0	AD7 to AD0	D7 to D0	AD7 to AD0	AD7 to AD0

9.1.3.1 Separate read and write strobe

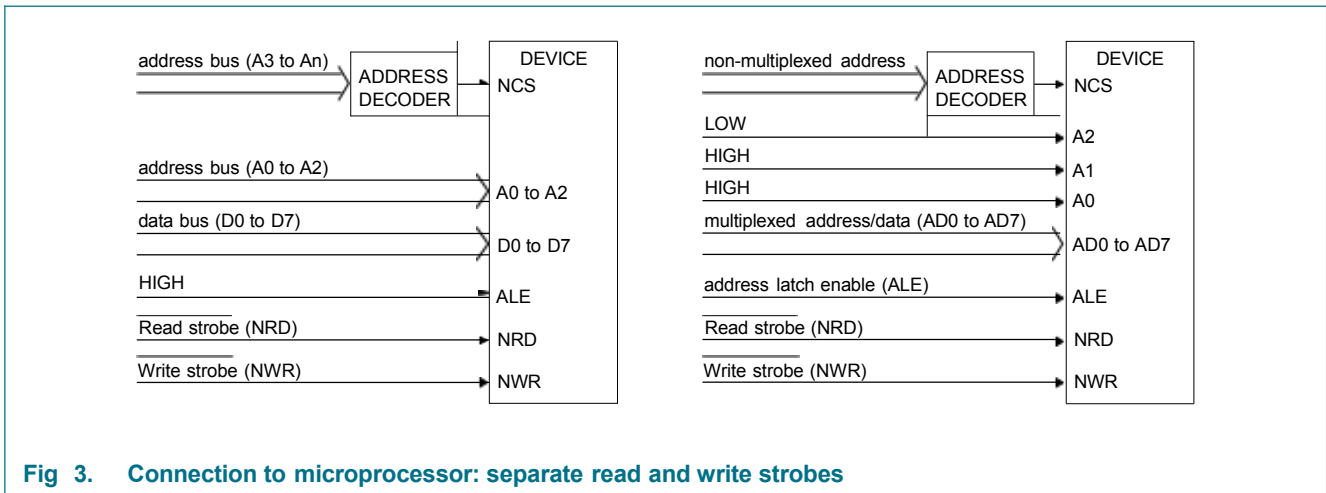
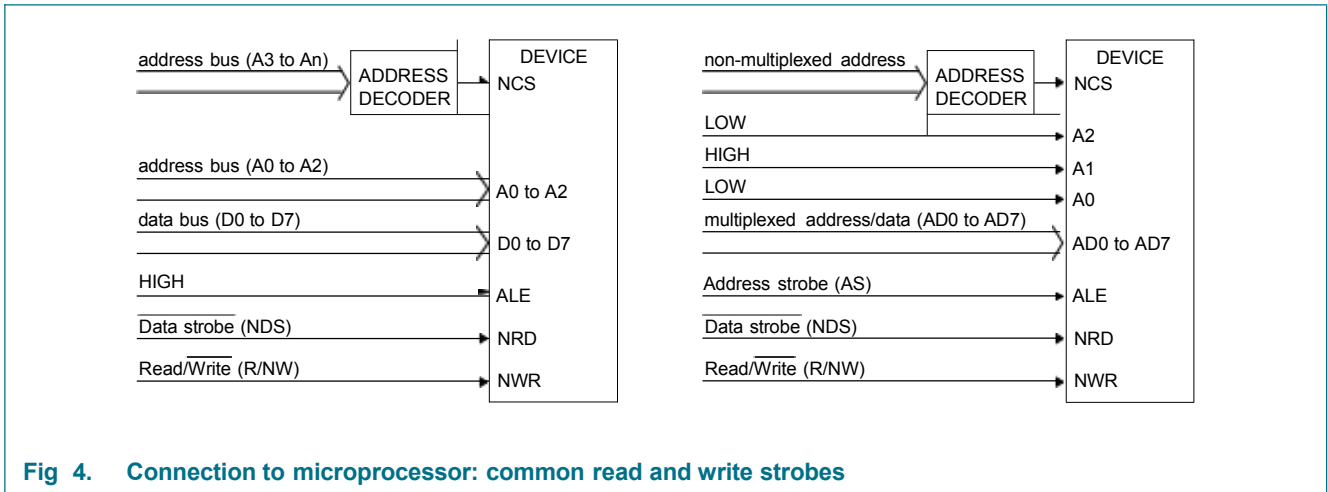

Fig 3. Connection to microprocessor: separate read and write strobes

Refer to Section 13.4.1 on page 102 for timing specification.



9.1.3.2 Common read and write strobe



Refer to [Section 13.4.2 on page 103](#) for timing specification.

9.1.3.3 Common read and write strobe: EPP with handshake

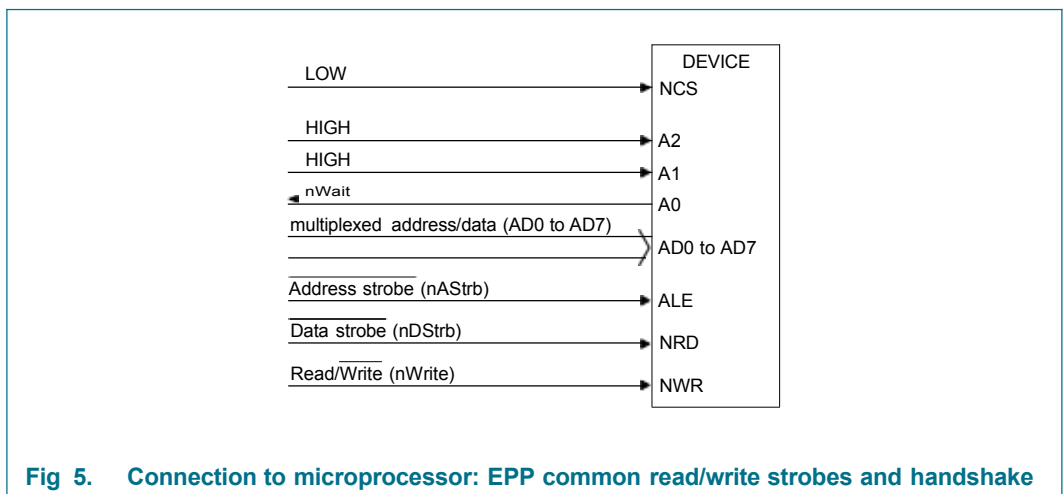

Refer to [Section 13.4.3 on page 104](#) for timing specification.

Remark: In the EPP standard a chip select signal is not defined. To cover this situation, the status of the NCS pin can be used to inhibit the nDStrb signal. If this inhibitor is not used, it is mandatory that pin NCS is connected to pin DVSS.

Remark: After each Power-On or Hard reset, the nWait signal on pin A0 is high-impedance. nWait is defined as the first negative edge applied to the nAStrb pin after the reset phase. The FSV9532 does not support Read Address Cycle.

9.1.4 Serial Peripheral Interface

The FSV9532 provides compatibility with the 5-wire Serial Peripheral Interface (SPI) standard and acts as a slave during the SPI communication. The SPI clock signal SCK must be generated by the master. Data communication from the master to the slave uses the MOSI line. The MISO line sends data from the FSV9532 to the master.



Table 6. SPI compatibility

FSV9532 pins	SPI pins
ALE	NSS
A2	SCK
A1	LOW
A0	MOSI
NRD	HIGH
NWR	HIGH
NCS	LOW
D7 to D1	do not connect
D0	MISO

Figure 6 shows the microprocessor connection to the FSV9532 using SPI.

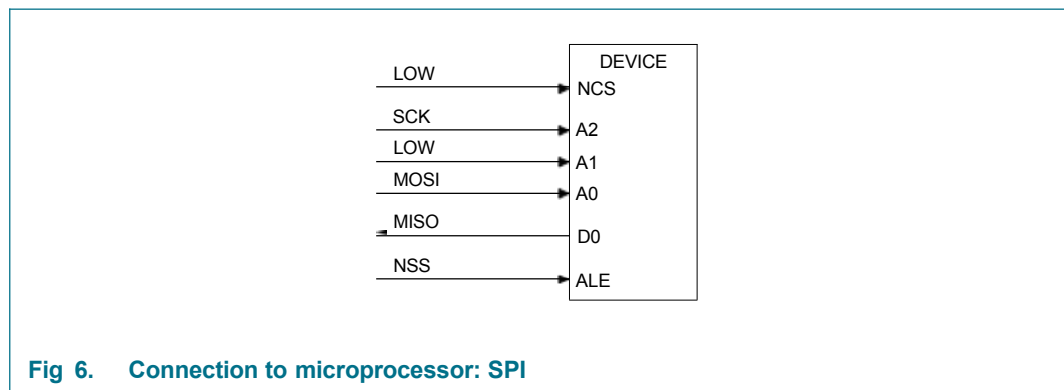

Remark: The SPI implementation for FSV9532 conforms to the SPI standard and ensures that the FSV9532 can only be addressed as a slave.

9.1.4.1 SPI read data

The structure shown in Table 7 must be used to read data using SPI. It is possible to read up to n-data bytes. The first byte sent defines both, the mode and the address.

Table 7. SPI read data

Pin	Byte 0	Byte 1	Byte 2	...	Byte n	Byte n + 1
MOSI	address 0	address 1	address 2	...	address n	00
MISO	XX	data 0	data 1	...	data n - 1	data n

The address byte must meet the following criteria:

- the Most Significant Bit (MSB) of the first byte sets the mode. To read data from the FSV9532 the MSB is set to logic 1
- bits [6:1] define the address
- the Least Significant Bit (LSB) should be set to logic 0.

As shown in Table 8, all the bits of the last byte sent are set to logic 0.



Table 8. SPI read address

Address (MOSI)	Bit 7 (MSB)	Bit 6	Bit 5	Bit 4	Bit 3	Bit 2	Bit 1	Bit 0 (LSB)
byte 0	1	address	address	address	address	address	address	reserved
byte 1 to byte n	reserved	address	address	address	address	address	address	reserved
byte n + 1	0	0	0	0	0	0	0	0

[1] All reserved bits must be set to logic 0.

9.1.4.2 SPI write data

The structure shown in [Table 9](#) must be used to write data using SPI. It is possible to write up to n-data bytes. The first byte sent defines both the mode and the address.

Table 9. SPI write data

	Byte 0	Byte 1	Byte 2	...	Byte n	Byte n + 1
MOSI	address	data 0	data 1	...	data n - 1	data n
MISO	XX	XX	XX	...	XX	XX

The address byte must meet the following criteria:

- the MSB of the first byte sets the mode. To write data to the FSV9532, the MSB is set to logic 0
- bits [6:1] define the address
- the LSB should be set to logic 0.

SPI write mode writes all data to the address defined in byte 0 enabling effective write cycles to the FIFO buffer.

Table 10. SPI write address

Address line (MOSI)	Bit 7 (MSB)	Bit 6	Bit 5	Bit 4	Bit 3	Bit 2	Bit 1	Bit 0 (LSB)
byte 0	0	address	address	address	address	address	address	reserved
byte 1 to byte n + 1	data	data	data	data	data	data	data	data

[1] All reserved bits must be set to logic 0.

Remark: The data bus pins D7 to D0 must be disconnected.

Refer to [Section 13.4.4 on page 106](#) for the timing specification.



9.2 Memory organization of the EEPROM

Table 11. EEPROM memory organization diagram

Block	Address	Byte address	Access	Memory content	Refer to
0	0	00h to 0Fh	R	product information field	Section 9.2.1 on page 13
1	1	10h to 1Fh	R/W	StartUp register initialization file	Section 9.2.2.1 on page 14
2	2	20h to 2Fh	R/W		
3	3	30h to 3Fh	R/W	register initialization file	Section 9.2.2.3 “Register initialization file (read/write)” on page 16
4	4	40h to 4Fh	R/W		
5	5	50h to 5Fh	R/W		
6	6	60h to 6Fh	R/W		
7	7	70h to 7Fh	R/W	user data or second initialization	
8	8	80h to 8Fh	W		
9	9	90h to 9Fh	W	keys for Crypto1	Section 9.2.3 on page 18
10	A	A0h to AFh	W		
11	B	B0h to BFh	W		
12	C	C0h to CFh	W		
13	D	D0h to DFh	W		
14	E	E0h to EFh	W		
15	F	F0h to FFh	W		
16	10	100h to 10Fh	W		
17	11	110h to 11Fh	W		
18	12	120h to 12Fh	W		
19	13	130h to 13Fh	W		
20	14	140h to 14Fh	W		
21	15	150h to 15Fh	W		
22	16	160h to 16Fh	W		
23	17	170h to 17Fh	W		
24	18	180h to 18Fh	W		
25	19	190h to 19Fh	W		
26	1A	1A0h to 1AFh	W		
27	1B	1B0h to 1BFh	W		
28	1C	1C0h to 1CFh	W		
29	1D	1D0h to 1DFh	W		
30	1E	1E0h to 1EFh	W		
31	1F	1F0h to 1FFh	W		



9.2.1 Product information field (read only)

Table 12. Product information field

Byte	Symbol	Access	Value	Description
15	CRC	R	-	the content of the product information field is secured using a CRC byte which is checked during start-up
14	RsMaxP	R	-	maximum source resistance for the p-channel driver transistor on pins TX1 and TX2 The source resistance of the p-channel driver transistors of pin TX1 and TX2 can be adjusted using the value GsCfgCW[5:0] in the CwConductance register (see Section 9.9.3 on page 32). The mean value of the maximum adjustable source resistance for pins TX1 and TX2 is stored as an integer value in Ω in this byte. Typical values for RsMaxP are between 60 Ω to 140 Ω . This value is denoted as maximum adjustable source resistance $RS_{(ref)maxP}$ and is measured by setting the CwConductance register's GsCfgCW[5:0] bits to 01h.
13 to 12	Internal	R	-	two bytes for internal trimming parameters
11 to 8	Product Serial Number	R	-	a unique four byte serial number for the device
7 to 5	reserved	R	-	
4 to 0	Product Type Identification	R	-	the FSV9532 is a member of a new family of highly integrated reader ICs. Each member of the product family has a unique product type identification. The value of the product type identification is shown in Table 13 .

Table 13. Product type identification definition

Definition	Product type identification bytes				
Byte	0	1	2	3	4 ^[1]
Value	30h	FFh	FFh	0Fh	XXh

[1] Byte 4 contains the current version number.

9.2.2 Register initialization files (read/write)

Register initialization from address 10h to address 2Fh is performed automatically during the initializing phase (see [Section 9.7.3 on page 30](#)) using the StartUp register initialization file.

In addition, the FSV9532 registers can be initialized using values from the register initialization file when the LoadConfig command is executed (see [Section 11.5.1 on page 95](#)).



Remark: The following points apply to initialization:

- the Page register (addressed using 10h, 18h, 20h, 28h) is skipped and not initialized.
- make sure that all PreSetxx registers are not changed.
- make sure that all register bits that are reserved are set to logic 0.

9.2.2.1 StartUp register initialization file (read/write)

The EEPROM memory block address 1 and 2 contents are used to automatically set the register subaddresses 10h to 2Fh during the initialization phase. The default values stored in the EEPROM during production are shown in [Section 9.2.2.2 “Factory default StartUp register initialization file”](#).

The byte assignment is shown in [Table 14](#).

Table 14. Byte assignment for register initialization at start-up

EEPROM byte address	Register address	Remark
10h (block 1, byte 0)	10h	skipped
11h	11h	copied
...
2Fh (block 2, byte 15)	2Fh	copied

9.2.2.2 Factory default StartUp register initialization file

During the production tests, the StartUp register initialization file is initialized using the default values shown in [Table 15](#). During each power-up and initialization phase, these values are written to the FSV9532's registers.



Table 15. Shipment content of StartUp configuration file

EEPROM byte address	Register address	Value	Symbol	Description
10h	10h	00h	Page	free for user
11h	11h	58h	TxControl	transmitter pins TX1 and TX2 are switched off, bridge driver configuration, modulator driven from internal digital circuitry
12h	12h	3Fh	CwConductance	source resistance of TX1 and TX2 is set to minimum
13h	13h	3Fh	ModConductance	defines the output conductance
14h	14h	19h	CoderControl	ISO/IEC 14443 A coding is set
15h	15h	13h	ModWidth	pulse width for Miller pulse coding is set to standard configuration
16h	16h	3Fh	ModWidthSOF	pulse width of Start Of Frame (SOF)
17h	17h	3Bh	TypeFraming	ISO/IEC 14443 A framing is set
18h	18h	00h	Page	free for user
19h	19h	73h	RxControl1	ISO/IEC 14443 A is set and internal amplifier gain is maximum
1Ah	1Ah	08h	DecoderControl	bit-collisions always evaluate to HIGH in the data bit stream
1Bh	1Bh	ADh	BitPhase	BitPhase[7:0] is set to standard configuration
1Ch	1Ch	FFh	RxThreshold	MinLevel[3:0] and CollLevel[3:0] are set to maximum
1Dh	1Dh	1Eh	BPSKDemControl	ISO/IEC 14443 A is set
1Eh	1Eh	41h	RxControl2	use Q-clock for the receiver, automatic receiver off is switched on, decoder is driven from internal analog circuitry
1Fh	1Fh	00h	ClockQControl	automatic Q-clock calibration is switched on
20h	20h	00h	Page	free for user
21h	21h	06h	RxWait	frame guard time is set to six bit-clocks
22h	22h	03h	ChannelRedundancy	channel redundancy is set using ISO/IEC 14443 A
23h	23h	63h	CRCPresetLSB	CRC preset value is set using ISO/IEC 14443 A
24h	24h	63h	CRCPresetMSB	CRC preset value is set using ISO/IEC 14443 A
25h	25h	00h	TimeSlotPeriod	defines the time for the I-CODE1 time slots
26h	26h	00h	MFOUTSelect	pin MFOUT is set LOW
27h	27h	00h	PreSet27	-
28h	28h	00h	Page	free for user
29h	29h	08h	FIFOLevel	WaterLevel[5:0] FIFO buffer warning level is set to standard configuration
2Ah	2Ah	07h	TimerClock	TPreScaler[4:0] is set to standard configuration, timer unit restart function is switched off
2Bh	2Bh	06h	TimerControl	Timer is started at the end of transmission, stopped at the beginning of reception
2Ch	2Ch	0Ah	TimerReload	TReloadValue[7:0]: the timer unit preset value is set to standard configuration
2Dh	2Dh	02h	IRQPinConfig	pin IRQ is set to high-impedance
2Eh	2Eh	00h	PreSet2E	-
2Fh	2Fh	00h	PreSet2F	-

Remark: The FSV9532 default configuration supports the MIFARE and ISO/IEC 14443 A communication scheme. Memory addresses 3 to 7 may be used for user-specific initialization files such as I-CODE1, ISO/IEC 15693 or ISO/IEC 14443 B.



9.2.2.3 Register initialization file (read/write)

The EEPROM memory content from block address 3 to 7 can initialize register sub addresses 10h to 2Fh when the LoadConfig command is executed (see [Section 11.5.1 on page 95](#)). This command requires the EEPROM starting byte address as a two byte argument for the initialization procedure.

The byte assignment is shown in [Table 16](#).

Table 16. Byte assignment for register initialization at startup

EEPROM byte address	Register address	Remark
EEPROM starting byte address	10h	skipped
EEPROM + 1 starting byte address	11h	copied

EEPROM + 31 starting byte address	2Fh	copied

The register initialization file is large enough to hold values for two initialization sets and up to one block (16-byte) of user data. The startup configuration could be adapted to the I-CODE1 StartUp configuration and stored in register block address 3 and 4, providing additional flexibility.

Remark: The register initialization file can be read/written by users and these bytes can be used to store other user data.

After each power-up, the default configuration enables the MIFARE and ISO/IEC 14443 A protocol.

9.2.2.4 Content of I-CODE1 and ISO/IEC 15693 StartUp register values

[Table 17](#) gives an overview of the StartUp values for I-CODE1 and ISO/IEC 15693 communication.



Table 17. Content of I-CODE1 startup configuration

EEPROM byte address	Register address	Value	Symbol	Description
30h	10h	00h	Page	free for user
31h	11h	58h	TxControl	transmitter pins TX1 and TX2 switched off, bridge driver configuration, modulator driven from internal digital circuitry
32h	12h	3Fh	CwConductance	source resistance (R_S) of TX1 and TX2 to minimum
33h	13h	05h	ModGsCfgh	source resistance (R_S) of TX1 and TX2 at the time of modulation, to determine the modulation index
34h	14h	2Ch	CoderControl	selects the bit coding mode and the framing during transmission
35h	15h	3Fh	ModWidth	pulse width for code used (1 out of 256, NRZ or 1 out of 4) pulse coding is set to standard configuration
36h	16h	3Fh	ModWidthSOF	pulse width of SOF
37h	17h	00h	TypeBFraming	-
38h	18h	00h	Page	free for user
39h	19h	8Bh	RxControl1	amplifier gain is maximum
3Ah	1Ah	00h	DecoderControl	bit-collisions always evaluate to HIGH in the data bit stream
3Bh	1Bh	54h	BitPhase	BitPhase[7:0] is set to standard configuration
3Ch	1Ch	68h	RxThreshold:	MinLevel[3:0] and CollLevel[3:0] are set to maximum
3Dh	1Dh	00h	BPSKDemControl	-
3Eh	1Eh	41h	RxControl2	use Q-clock for the receiver, automatic receiver off is switched on, decoder is driven from internal analog circuitry
3Fh	1Fh	00h	ClockQControl	automatic Q-clock calibration is switched on
40h	20h	00h	Page	free for user
41h	21h	08h	RxWait	frame guard time is set to eight bit-clocks
42h	22h	0Ch	ChannelRedundancy	channel redundancy is set using I-CODE1
43h	23h	FEh	CRCPreSetLSB	CRC preset value is set using I-CODE1
44h	24h	FFh	CRCPreSetMSB	CRC preset value is set using I-CODE1
45h	25h	00h	TimeSlot Period	defines the time for the I-CODE1 time slots
46h	26h	00h	MFOUTSelect	pin MFOUT is set LOW
47h	27h	00h	PreSet27	-
48h	28h	00h	Page	free for user
49h	29h	3Eh	FIFOLevel	WaterLevel[5:0] FIFO buffer warning level is set to standard configuration
4Ah	2Ah	0Bh	TimerClock	TPreScaler[4:0] is set to standard configuration, timer unit restart function is switched off
4Bh	2Bh	02h	TimerControl	Timer is started at the end of transmission, stopped at the beginning of reception
4Ch	2Ch	00h	TimerReload	the timer unit preset value is set to standard configuration
4Dh	2Dh	02h	IRQPinConfig	pin IRQ is set to high-impedance
4Eh	2Eh	00h	PreSet2E	-
4Fh	2Fh	00h	PreSet2F	-



9.2.3 Crypto1 keys (write only)

MIFARE security requires specific cryptographic keys to encrypt data stream communication on the contactless interface. These keys are called Crypto1 keys.

9.2.3.1 Key format

Keys stored in the EEPROM are written in a specific format. Each key byte must be split into lower four bits k0 to k3 (lower nibble) and the higher four bits k4 to k7 (higher nibble). Each nibble is stored twice in one byte and one of the two nibbles is bit-wise inverted. This format is a precondition for successful execution of the LoadKeyE2 (see [Section 11.7.1 on page 97](#)) and LoadKey commands (see [Section 11.7.2 on page 97](#)).

Using this format, 12 bytes of EEPROM memory are needed to store a 6-byte key. This is shown in [Figure 7](#).

Master key byte	0 (LSB)		1		//	5 (MSB)	
Master key bits	$\overline{k7\ k6\ k5\ k4\ k7\ k6\ k5\ k4}$	$\overline{k3\ k2\ k1\ k0\ k3\ k2\ k1\ k0}$	$\overline{k7\ k6\ k5\ k4\ k7\ k6\ k5\ k4}$	$\overline{k3\ k2\ k1\ k0\ k3\ k2\ k1\ k0}$	//	$\overline{k7\ k6\ k5\ k4\ k7\ k6\ k5\ k4}$	$\overline{k3\ k2\ k1\ k0\ k3\ k2\ k1\ k0}$
EEPROM byte address	n	n + 1	n + 2	n + 3	//	n + 10	n + 11
Example	5Ah	F0h	5Ah	E1h	//	5Ah	A5h

Fig 7. Key storage format

Example: The value for the key must be written to the EEPROM.

- If the key was: A0h A1h A2h A3h A4h A5h then
- 5Ah F0h 5Ah E1h 5Ah D2h 5Ah C3h 5Ah B4h 5Ah A5h would be written.

Remark: It is possible to load data for other key formats into the EEPROM key storage location. However, it is not possible to validate card authentication with data which will cause the LoadKeyE2 command (see [Section 11.7.1 on page 97](#)) to fail.

9.2.3.2 Storage of keys in the EEPROM

The FSV9532 reserves 384 bytes of memory in the EEPROM for the Crypto1 keys. No memory segmentation is used to mirror the 12-byte structure of key storage. Thus, every byte of the dedicated memory area can be the start of a key.

Example: If the key loading cycle starts at the last byte address of an EEPROM block, (for example, key byte 0 is stored at 12Fh), the next bytes are stored in the next EEPROM block, for example, key byte 1 is stored at 130h, byte 2 at 131h up to byte 11 at 13Ah.

Based on the 384 bytes of memory and a single key needing 12 bytes, then up to 32 different keys can be stored in the EEPROM.

Remark: It is not possible to load a key exceeding the EEPROM byte location 1FFh.



9.3 FIFO buffer

An 8 × 64 bit FIFO buffer is used in the FSV9532 to act as a parallel-to-parallel converter. It buffers both the input and output data streams between the microprocessor and the internal circuitry of the FSV9532. This makes it possible to manage data streams up to 64 bytes long without needing to take timing constraints into account.

9.3.1 Accessing the FIFO buffer

9.3.1.1 Access rules

The FIFO buffer input and output data bus is connected to the FIFOData register. Writing to this register stores one byte in the FIFO buffer and increments the FIFO buffer write pointer. Reading from this register shows the FIFO buffer contents stored at the FIFO buffer read pointer and increments the FIFO buffer read pointer. The distance between the write and read pointer can be obtained by reading the FIFOLength register.

When the microprocessor starts a command, the FSV9532 can still access the FIFO buffer while the command is running. Only one FIFO buffer has been implemented which is used for input and output. Therefore, the microprocessor must ensure that there are no inadvertent FIFO buffer accesses. Table 18 gives an overview of FIFO buffer access during command processing.

Table 18. FIFO buffer access

Active command	FIFO buffer		Remark
	µp Write	µp Read	
StartUp	-	-	
Idle	-	-	
Transmit	yes	-	
Receive	-	yes	
Transceive	yes	yes	the microprocessor has to know the state of the command (transmitting or receiving)
WriteE2	yes	-	
ReadE2	yes	yes	the microprocessor has to prepare the arguments, afterwards only reading is allowed
LoadKeyE2	yes	-	
LoadKey	yes	-	
Authent1	yes	-	
Authent2	-	-	
LoadConfig	yes	-	
CalcCRC	yes	-	

9.3.2 Controlling the FIFO buffer

In addition to writing to and reading from the FIFO buffer, the FIFO buffer pointers can be reset using the FlushFIFO bit. This changes the FIFOLength[6:0] value to zero, bit FIFOOvfl is cleared and the stored bytes are no longer accessible. This enables the FIFO buffer to be written with another 64 bytes of data.



9.3.3 FIFO buffer status information

The microprocessor can get the following FIFO buffer status data:

- the number of bytes stored in the FIFO buffer: bits FIFOLength[6:0]
- the FIFO buffer full warning: bit HiAlert
- the FIFO buffer empty warning: bit LoAlert
- the FIFO buffer overflow warning: bit FIFOOvfl.

Remark: Setting the FlushFIFO bit clears the FIFOOvfl bit.

The FSV9532 can generate an interrupt signal when:

- bit LoAlertIRq is set to logic 1 and bit LoAlert = logic 1, pin IRQ is activated.
- bit HiAlertIRq is set to logic 1 and bit HiAlert = logic 1, pin IRQ activated.

The HiAlert flag bit is set to logic 1 only when the WaterLevel[5:0] bits or less can be stored in the FIFO buffer. The trigger is generated by [Equation 1](#):

$$\text{HiAlert} = \text{FIFOLength} \leq \text{WaterLevel}$$

The LoAlert flag bit is set to logic 1 when the FIFOLevel register's WaterLevel[5:0] bits or less are stored in the FIFO buffer. The trigger is generated by [Equation 2](#):

$$\text{LoAlert} = \text{FIFOLength} \leq \text{WaterLevel}$$

9.3.4 FIFO buffer registers and flags

[Table 18](#) shows the related FIFO buffer flags in alphabetic order.

Table 19. Associated FIFO buffer registers and flags

Flags	Register name	Bit	Register address
FIFOLength[6:0]	FIFOLength	6 to 0	04h
FIFOOvfl	ErrorFlag	4	0Ah
FlushFIFO	Control	0	09h
HiAlert	PrimaryStatus	1	03h
HiAlertEn	InterruptEn	1	06h
HiAlertIRq	InterruptRq	1	07h
LoAlert	PrimaryStatus	0	03h
LoAlertEn	InterruptEn	0	06h
LoAlertIRq	InterruptRq	0	07h
WaterLevel[5:0]	FIFOLevel	5 to 0	29h

9.4 Interrupt request system

The FSV9532 indicates interrupt events by setting the PrimaryStatus register bit IRq (see [Section 10.5.1.4 “PrimaryStatus register” on page 51](#)) and activating pin IRQ. The signal on pin IRQ can be used to interrupt the microprocessor using its interrupt handling capabilities ensuring efficient microprocessor software.



9.4.1 Interrupt sources overview

Table 20 shows the integrated interrupt flags, related source and setting condition. The interrupt TimerIRq flag bit indicates an interrupt set by the timer unit. Bit TimerIRq is set when the timer decrements from one down to zero (bit TAutoRestart disabled) or from one to the TReLoadValue[7:0] with bit TAutoRestart enabled.

Bit TxIRq indicates interrupts from different sources and is set as follows:

- the transmitter automatically sets the bit TxIRq interrupt when it is active and its state changes from sending data to transmitting the end of frame pattern
- the CRC coprocessor sets the bit TxIRq after all data from the FIFO buffer has been processed indicated by bit CRCReady = logic 1
- when EEPROM programming is finished, the bit TxIRq is set and is indicated by bit E2Ready = logic 1

The RxIRq flag bit indicates an interrupt when the end of the received data is detected. The IdleIRq flag bit is set when a command finishes and the content of the Command register changes to Idle.

When the FIFO buffer reaches the HIGH-level indicated by the WaterLevel[5:0] value (see Section 9.3.3 on page 20) and bit HiAlert = logic 1, then the HiAlertIRq flag bit is set to logic 1.

When the FIFO buffer reaches the LOW-level indicated by the WaterLevel[5:0] value (see Section 9.3.3 on page 20) and bit LoAlert = logic 1, then LoAlertIRq flag bit is set to logic 1.

Table 20. Interrupt sources

Interrupt flag	Interrupt source	Trigger action
TimerIRq	timer unit	timer counts from 1 to 0
TxIRq	transmitter	a data stream, transmitted to the card, ends
	CRC coprocessor	all data from the FIFO buffer has been processed
	EEPROM	all data from the FIFO buffer has been programmed
RxIRq	receiver	a data stream, received from the card, ends
IdleIRq	Command register	command execution finishes
HiAlertIRq	FIFO buffer	FIFO buffer is full
LoAlertIRq	FIFO buffer	FIFO buffer is empty

9.4.2 Interrupt request handling

9.4.2.1 Controlling interrupts and getting their status

The FSV9532 informs the microprocessor about the interrupt request source by setting the relevant bit in the InterruptRq register. The relevance of each interrupt request bit as source for an interrupt can be masked by the InterruptEn register interrupt enable bits.

Table 21. Interrupt control registers

Register	Bit 7	Bit 6	Bit 5	Bit 4	Bit 3	Bit 2	Bit 1	Bit 0
InterruptEn	SetIEn	reserved	TimerIEn	TxIEn	RxIEn	IdleIEn	HiAlertIEn	LoAlertIEn
InterruptRq	SetIRq	reserved	TimerIRq	TxIRq	RxIRq	IdleIRq	HiAlertIRq	LoAlertIRq



If any interrupt request flag is set to logic 1 (showing that an interrupt request is pending) and the corresponding interrupt enable flag is set, the PrimaryStatus register IRq flag bit is set to logic 1. Different interrupt sources can activate simultaneously because all interrupt request bits are OR'ed, coupled to the IRq flag and then forwarded to pin IRQ.

9.4.2.2 Accessing the interrupt registers

The interrupt request bits are automatically set by the FSV9532's internal state machines. In addition, the microprocessor can also set or clear the interrupt request bits as required.

A special implementation of the InterruptRq and InterruptEn registers enables changing an individual bit status without influencing any other bits. If an interrupt register is set to logic 1, bit Setlxx and the specific bit must both be set to logic 1 at the same time. Vice versa, if a specific interrupt flag is cleared, zero must be written to the Setlxx and the interrupt register address must be set to logic 1 at the same time.

If a content bit is not changed during the setting or clearing phase, zero must be written to the specific bit location.

Example: Writing 3Fh to the InterruptRq register clears all bits. SetIRq is set to logic 0 while all other bits are set to logic 1. Writing 81h to the InterruptRq register sets LoAlertIRq to logic 1 and leaves all other bits unchanged.

9.4.3 Configuration of pin IRQ

The logic level of the IRq flag bit is visible on pin IRQ. The signal on pin IRQ can also be controlled using the following IRQPinConfig register bits.

- bit IRQInv: the signal on pin IRQ is equal to the logic level of bit IRq when this bit is set to logic 0. When set to logic 1, the signal on pin IRQ is inverted with respect to bit IRq.
- bit IRQPushPull: when set to logic 1, pin IRQ has CMOS output characteristics. When it is set to logic 0, it is an open-drain output which requires an external resistor to achieve a HIGH-level at pin IRQ.

Remark: During the reset phase (see [Section 9.7.2 on page 29](#)) bit IRQInv is set to logic 1 and bit IRQPushPull is set to logic 0. This results in a high-impedance on pin IRQ.



9.4.4 Register overview interrupt request system

Table 22 shows the related interrupt request system flags in alphabetic order.

Table 22. Associated Interrupt request system registers and flags

Flags	Register name	Bit	Register address
HiAlertIEn	InterruptEn	1	06h
HiAlertIRq	InterruptRq	1	07h
IdleIEn	InterruptEn	2	06h
IdleIRq	InterruptRq	2	07h
IRq	PrimaryStatus	3	03h
IRQInv	IRQPinConfig	1	07h
IRQPushPull	IRQPinConfig	0	07h
LoAlertIEn	InterruptEn	0	06h
LoAlertIRq	InterruptRq	0	07h
RxIEn	InterruptEn	3	06h
RxIRq	InterruptRq	3	07h
SetIEn	InterruptEn	7	06h
SetIRq	InterruptRq	7	07h
TimerIEn	InterruptEn	5	06h
TimerIRq	InterruptRq	5	07h
TxIEn	InterruptEn	4	06h
TxIRq	InterruptRq	4	07h

9.5 Timer unit

The timer derives its clock from the 13.56 MHz on-board chip clock. The microprocessor can use this timer to manage timing-relevant tasks.

The timer unit may be used in one of the following configurations:

- Timeout counter
- WatchDog counter
- Stopwatch
- Programmable one shot
- Periodical trigger

The timer unit can be used to measure the time interval between two events or to indicate that a specific timed event occurred. The timer is triggered by events but does not influence any event (e.g. a time-out during data receiving does not automatically influence the receiving process). Several timer related flags can be set and these flags can be used to generate an interrupt.



9.5.1 Timer unit implementation

9.5.1.1 Timer unit block diagram

Figure 8 shows the block diagram of the timer module.

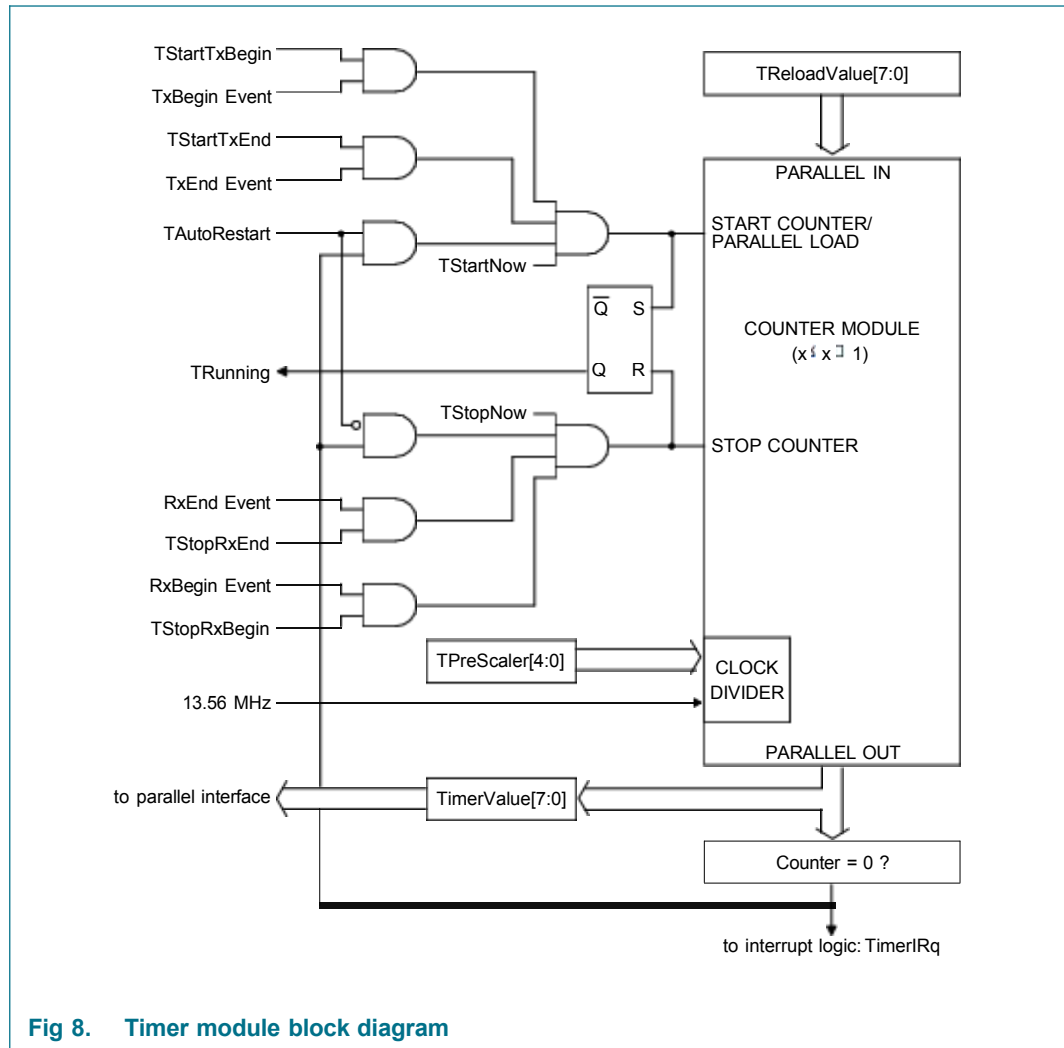

Fig 8. Timer module block diagram

The timer unit is designed, so that events when combined with enabling flags start or stop the counter. For example, setting bit `TStartTxBegin` = logic 1 enables control of received data with the timer unit. In addition, the first received bit is indicated by the `TxBegin` event. This combination starts the counter at the defined `TReloadValue[7:0]`.

The timer stops automatically when the counter value is equal to zero or if a defined stop event happens.

9.5.1.2 Controlling the timer unit

The main part of the timer unit is a down-counter. As long as the down-counter value is not zero, it decrements its value with each timer clock cycle.

If the `TAutoRestart` flag is enabled, the timer does not decrement down to zero. On reaching value 1, the timer reloads the next clock function with the `TReloadValue[7:0]`.



The timer is started immediately by loading a value from the TimerReload register into the counter module.

This is activated by one of the following events:

- transmission of the first bit to the card (TxBegin event) with bit TStartTxBegin = logic 1
- transmission of the last bit to the card (TxEnd event) with bit TStartTxEnd = logic 1
- bit TStartNow is set to logic 1 by the microprocessor

Remark: Every start event reloads the timer from the TimerReload register. Thus, the timer unit is re-triggered.

The timer can be configured to stop on one of the following events:

- receipt of the first valid bit from the card (RxBegin event) with bit TStopRxBegin = logic 1
- receipt of the last bit from the card (RxEnd event) with bit TStopRxEnd = logic 1
- the counter module has decremented down to zero and bit TAutoRestart = logic 0
- bit TStopNow is set to logic 1 by the microprocessor.

Loading a new value, e.g. zero, into the TimerReload register or changing the timer unit while it is counting will not immediately influence the counter. In both cases, this is because this register only affects the counter content after a start event.

If the counter is stopped when bit TStopNow is set, no TimerLRq is flagged.

9.5.1.3 Timer unit clock and period

The timer unit clock is derived from the 13.56 MHz on-board chip clock using the programmable divider. Clock selection is made using the TimerClock register TPreScaler[4:0] bits based on [Equation 3](#):

$$f_{TimerClock} = \frac{1}{T_{TimerClock}} = \frac{2^{TPreScaler}}{13.56} [MHz]$$

The values for the TPreScaler[4:0] bits are between 0 and 21 which results in a minimum periodic time ($T_{TimerClock}$) of between 74 ns and 150 ms.

The time period elapsed since the last start event is calculated using [Equation 4](#):

$$t_{Timer} = \frac{TReLoadValue - TimerValue}{f_{TimerClock}} []$$

This results in a minimum time period (t_{Timer}) of between 74 ns and 40 s.

9.5.1.4 Timer unit status

The SecondaryStatus register's TRunning bit shows the timer's status. Configured start events start the timer at the TReloadValue[7:0] and changes the status flag TRunning to logic 1. Conversely, configured stop events stop the timer and sets the TRunning status flag to logic 0. As long as status flag TRunning is set to logic 1, the TimerValue register changes on the next timer unit clock cycle.

The TimerValue[7:0] bits can be read directly from the TimerValue register.



9.5.1.5 TimeSlotPeriod

When sending I-CODE1 Quit frames, it is necessary to generate the exact chronological relationship to the start of the command frame.

If at the end of command execution $\text{TimeSlotPeriod} > 0$, the TimeSlotPeriod starts. If the FIFO buffer contains data when the end of TimeSlotPeriod is reached, the data is sent. If the FIFO buffer is empty nothing happens. As long as the TimeSlotPeriod is > 0 , the TimeSlotPeriod counter automatically starts on reaching the end.

This forms the exact time relationship between the start and finish of the command frame used to generate and send I-CODE1 Quit frames.

When the $\text{TimeSlotPeriod} > 0$, the next Frame starts with exactly the same interval $\text{TimeSlotPeriod}/\text{CoderRate}$ delayed after each previous send frame. CoderRate defines the clock frequency of the encoder. If $\text{TimeSlotPeriod}[7:0] = 0$, the send function is not automatically triggered.

The content of the TimeSlotPeriod register can be changed while it is running but the change is only effective after the next TimeSlotPeriod restart.

Example:

- CoderRate = 0×0.5 (~52.97 kHz)
- The interval should be 8.458 ms for I-CODE1 standard mode

$$\rightarrow \text{TimeSlotPeriod} = \text{CoderRate} \times \text{Interval} = 52.97 \text{ kHz} \times 8.458 \text{ ms} - 1 = 447 = 1BFh$$

Remark: The TimeSlotPeriodMSB bit is contained in the MFOUTSelect register.

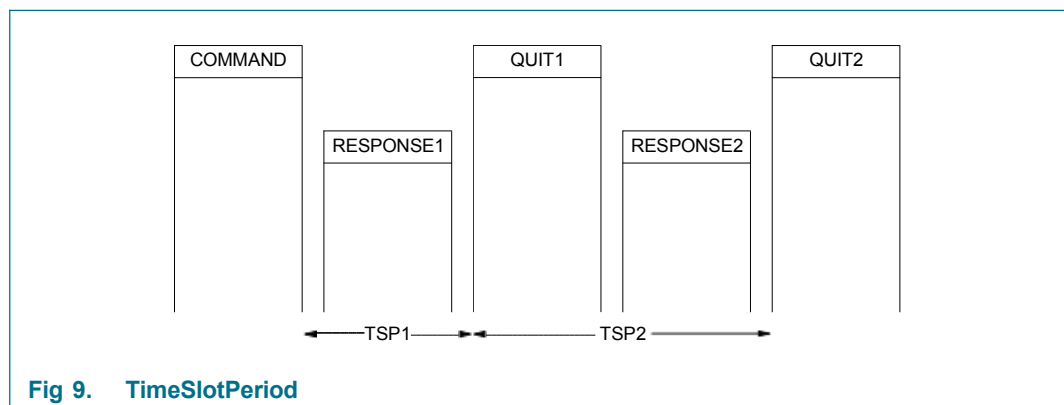

Table 23. TimeSlotPeriod

I-CODE1 mode	TimeSlotPeriod for TSP1	TimeSlotPeriod for TSP2
standard mode	BFh	1BFh
fast mode	5Fh	67h

Remark: Set bit TxCRCEn to logic 0 before the Quit frame is sent. If TxCRCEn is not set to logic 0, the Quit frame is sent with a calculated CRC value. Use the CRC8 algorithm to calculate the Quit value.



9.5.2 Using the timer unit functions

9.5.2.1 Time-out and WatchDog counters

After starting the timer using TReloadValue[7:0], the timer unit decrements the TimerValue register beginning with a given start event. If a given stop event occurs, such as a bit being received from the card, the timer unit stops without generating an interrupt.

If a stop event does not occur, such as the card not answering within the expected time, the timer unit decrements down to zero and generates a timer interrupt request. This signals to the microprocessor the expected event has not occurred within the given time (t_{Timer}).

9.5.2.2 Stopwatch

The time (t_{Timer}) between a start and stop event is measured by the microprocessor using the timer unit. Setting the TReloadValue register triggers the timer which in turn, starts to decrement. If the defined stop event occurs, the timer stops. The time between start and stop is calculated by the microprocessor using Equation 5, when the timer does not decrement down to zero.

$$\Delta t = TReLoad_{value} \leftarrow TimerValue \times t_{Timer}$$

9.5.2.3 Programmable one shot timer and periodic trigger

Programmable one shot timer: The microprocessor starts the timer unit and waits for the timer interrupt. The interrupt occurs after the time specified by t_{Timer} .

Periodic trigger: If the microprocessor sets the TAutoRestart bit, it generates an interrupt request after every t_{Timer} cycle.

9.5.3 Timer unit registers

Table 24 shows the related flags of the timer unit in alphabetical order.

Table 24. Associated timer unit registers and flags

Flags	Register name	Bit	Register address
TAutoRestart	TimerClock	5	2Ah
TimerValue[7:0]	TimerValue	7 to 0	0Ch
TReloadValue[7:0]	TimerReload	7 to 0	2Ch
TPreScaler[4:0]	TimerClock	4 to 0	2Ah
TRunning	SecondaryStatus	7	05h
TStartNow	Control	1	09h
TStartTxBegin	TimerControl	0	2Bh
TStartTxEnd	TimerControl	1	2Bh
TStopNow	Control	2	09h
TStopRxBegin	TimerControl	2	2Bh
TStopRxEnd	TimerControl	3	2Bh



9.6 Power reduction modes

9.6.1 Hard power-down

Hard power-down is enabled when pin RSTPD is HIGH. This turns off all internal current sinks including the oscillator. All digital input buffers are separated from the input pads and defined internally (except pin RSTPD itself). The output pins are frozen at a given value. The status of all pins during a hard power-down is shown in [Table 25](#).

Table 25. Signal on pins during Hard power-down

Symbol	Pin	Type	Description
OSCIN	1	I	not separated from input, pulled to AVSS
IRQ	2	O	high-impedance
MFIN	3	I	separated from input
MFOUT	4	O	LOW
TX1	5	O	HIGH, if bit TX1RFEn = logic 1 LOW, if bit TX1RFEn = logic 0
TX2	7	O	HIGH, only if bit TX2RFEn = logic 1 and bit TX2Inv = logic 0 otherwise LOW
NCS	9	I	separated from input
NWR	10	I	separated from input
NRD	11	I	separated from input
D0 to D7	13 to 20	I/O	separated from input
ALE	21	I	separated from input
A0	22	I/O	separated from input
A1	23	I	separated from input
A2	24	I	separated from input
AUX	27	O	high-impedance
RX	29	I	not changed
VMID	30	A	pulled to V _{DDA}
RSTPD	31	I	not changed
OSCOUT	32	O	HIGH

9.6.2 Soft power-down mode

Soft power-down mode is entered immediately using the Control register bit PowerDown. All internal current sinks, including the oscillator buffer, are switched off. The digital input buffers are not separated from the input pads and keep their functionality. In addition, the digital output pins do not change their state.

After resetting the Control register bit PowerDown, the bit indicating Soft power-down mode is only cleared after 512 clock cycles. Resetting it does not immediately clear it. The PowerDown bit is automatically cleared when the Soft power-down mode is exited.

Remark: When the internal oscillator is used, time (t_{osc}) is required for the oscillator to become stable. This is because the internal oscillator is supplied by V_{DDA} and any clock cycles will not be detected by the internal logic until V_{DDA} is stable.



9.6.3 Standby mode

The Standby mode is immediately entered when the Control register StandBy bit is set. All internal current sinks, including the internal digital clock buffer are switched off. However, the oscillator buffer is not switched off.

The digital input buffers are not separated by the input pads, keeping their functionality and the digital output pins do not change their state. In addition, the oscillator does not need time to wake-up.

After resetting the Control register StandBy bit, it takes four clock cycles on pin OSCIN for Standby mode to exit. Resetting bit StandBy does not immediately clear it. It is automatically cleared when the Standby mode is exited.

9.6.4 Automatic receiver power-down

It is a power saving feature to switch off the receiver circuit when it is not needed. Setting bit RxAutoPD = logic 1, automatically powers down the receiver when it is not in use. Setting bit RxAutoPD = logic 0, keeps the receiver continuously powered up.

9.7 StartUp phase

The events executed during the StartUp phase are shown in [Figure 10](#).

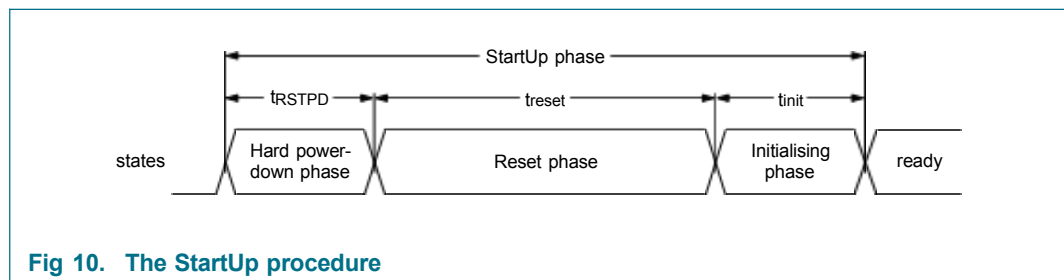

Fig 10. The StartUp procedure

9.7.1 Hard power-down phase

The hard power-down phase is active during the following cases:

- a Power-On Reset (POR) caused by power-up on pins DVDD or AVDD activated when V_{DDD} or V_{DDA} is below the digital reset threshold.
- a HIGH-level on pin RSTPD which is active while pin RSTPD is HIGH. The HIGH level period on pin RSTPD must be at least 100 μ s ($t_{PD} \geq 100 \mu$ s). Shorter phases will not necessarily result in the reset phase (t_{reset}). The rising or falling edge slew rate on pin RSTPD is not critical because pin RSTPD is a Schmitt trigger input.

9.7.2 Reset phase

The reset phase automatically follows the Hard power-down. Once the oscillator is running stably, the reset phase takes 512 clock cycles. During the reset phase, some register bits are preset by hardware. The respective reset values are given in the description of each register (see [Section 10.5 on page 50](#)).

Remark: When the internal oscillator is used, time (t_{osc}) is required for the oscillator to become stable. This is because the internal oscillator is supplied by V_{DDA} and any clock cycles will not be detected by the internal logic until V_{DDA} is stable.



9.7.3 Initialization phase

The initialization phase automatically follows the reset phase and takes 128 clock cycles. During the initializing phase the content of the EEPROM blocks 1 and 2 is copied into the register subaddresses 10h to 2Fh (see [Section 9.2.2 on page 13](#)).

Remark: During the production test, the FSV9532 is initialized with default configuration values. This reduces the microprocessor's configuration time to a minimum.

9.7.4 Initializing the parallel interface type

A different initialization sequence is used for each microprocessor. This enables detection of the correct microprocessor interface type and synchronization of the microprocessor's and the FSV9532's start-up. See [Section 9.1.3 on page 8](#) for detailed information on the different connections for each microprocessor interface type.

During StartUp phase, the command value is set to 3Fh once the oscillator attains clock frequency stability at an amplitude of > 90 % of the nominal 13.56 MHz clock frequency. At the end of the initialization phase, the FSV9532 automatically switches to idle and the command value changes to 00h.

To ensure correct detection of the microprocessor interface, the following sequence is executed:

- the Command register is read until the 6-bit register value is 00h. On reading the 00h value, the internal initialization phase is complete and the FSV9532 is ready to be controlled
- write 80h to the Page register to initialize the microprocessor interface
- read the Command register. If it returns a value of 00h, the microprocessor interface was successfully initialized
- write 00h to the Page registers to activate linear addressing mode.

9.8 Oscillator circuit

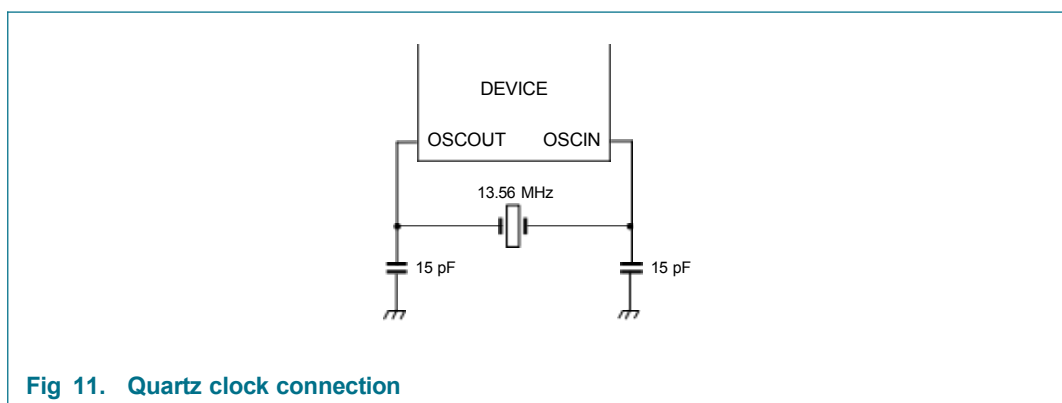

The clock applied to the FSV9532 acts as a time basis for the synchronous system encoder and decoder. The stability of the clock frequency is an important factor for correct operation. To obtain highest performance, clock jitter must be as small as possible. This is best achieved by using the internal oscillator buffer with the recommended circuitry.



If an external clock source is used, the clock signal must be applied to pin OSCIN. In this case, be very careful in optimizing clock duty cycle and clock jitter. Ensure the clock quality has been verified. It must meet the specifications described in [Section 13.4.5 on page 106](#).

Remark: We do not recommend using an external clock source.

9.9 Transmitter pins TX1 and TX2

The signal on pins TX1 and TX2 is the 13.56 MHz energy carrier modulated by an envelope signal. It can be used to drive an antenna directly, using minimal passive components for matching and filtering (see [Section 15.1 on page 107](#)). To enable this, the output circuitry is designed with a very low-impedance source resistance. The TxControl register is used to control the TX1 and TX2 signals.

9.9.1 Configuring pins TX1 and TX2

TX1 pin configurations are described in [Table 26](#).

Table 26. Pin TX1 configurations

TxControl register configuration		Envelope	TX1 signal
TX1RFEn	FORCE100ASK		
0	X	X	LOW (GND)
1	0	0	13.56 MHz carrier frequency modulated
1	0	1	13.56 MHz carrier frequency
1	1	0	LOW
1	1	1	13.56 MHz energy carrier

TX2 pin configurations are described in [Table 27](#).



Table 27. Pin TX2 configurations

TxControl register configuration				Envelope	TX2 signal
TX2RFEn	FORCE100ASK	TX2CW	TX2Inv		
0	X	X	X	X	LOW
1	0	0	0	0	13.56 MHz carrier frequency modulated
1	0	0	0	1	13.56 MHz carrier frequency
1	0	0	1	0	13.56 MHz carrier frequency modulated, 180° phase-shift relative to TX1
1	0	0	1	1	13.56 MHz carrier frequency, 180° phase-shift relative to TX1
1	0	1	0	X	13.56 MHz carrier frequency
1	0	1	1	X	13.56 MHz carrier frequency, 180° phase-shift relative to TX1
1	1	0	0	0	LOW
1	1	0	0	1	13.56 MHz carrier frequency
1	1	0	1	0	HIGH
1	1	0	1	1	13.56 MHz carrier frequency, 180° phase-shift relative to TX1
1	1	1	0	X	13.56 MHz carrier frequency
1	1	1	1	X	13.56 MHz carrier frequency, 180° phase-shift relative to TX1

9.9.2 Antenna operating distance versus power consumption

Using different antenna matching circuits (by varying the supply voltage on the antenna driver supply pin TVDD), it is possible to find the trade-off between maximum effective operating distance and power consumption. Different antenna matching circuits are described in the Application note “*MIFARE Design of CS9605 Matching Circuit and Antennas*”.

9.9.3 Antenna driver output source resistance

The output source conductance of pins TX1 and TX2 can be adjusted between 1 Ω and 100 Ω using the CwConductance register GsCfgCW[5:0] bits.

The output source conductance of pins TX1 and TX2 during the modulation phase can be adjusted between 1 Ω and 100 Ω using the ModConductance register GsCfgMod[5:0] bits.

The values are relative to the reference resistance ($R_{S(ref)}$) which is measured during the production test and stored in the FSV9532 EEPROM. It can be read from the product information field (see [Section 9.2.1 on page 13](#)). The electrical specification can be found in [Section 13.3.3 on page 101](#).



9.9.3.1 Source resistance table

Table 28. TX1 and TX2 source resistance of n-channel driver transistor against GsCfgCW or GsCfgMod

MANT = Mantissa; EXP= Exponent.

GsCfgCW, GsCfgMod (decimal)	EXP _{GsCfgCW} , EXP _{GsCfgMod} (decimal)	MANT _{GsCfgCW} , MANT _{GsCfgMod} (decimal)	RS(ref) (Ω)	GsCfgCW, GsCfgMod (decimal)	EXP _{GsCfgCW} , EXP _{GsCfgMod} (decimal)	MANT _{GsCfgCW} , MANT _{GsCfgMod} (decimal)	RS(ref) (Ω)
0	0	0	-	24	1	8	0.0652
16	1	0	-	25	1	9	0.0580
32	2	0	-	37	2	5	0.0541
48	3	0	-	26	1	10	0.0522
1	0	1	1.0000	27	1	11	0.0474
17	1	1	0.5217	51	3	3	0.0467
2	0	2	0.5000	38	2	6	0.0450
3	0	3	0.3333	28	1	12	0.0435
33	2	1	0.2703	29	1	13	0.0401
18	1	2	0.2609	39	2	7	0.0386
4	0	4	0.2500	30	1	14	0.0373
5	0	5	0.2000	52	3	4	0.0350
19	1	3	0.1739	31	1	15	0.0348
6	0	6	0.1667	40	2	8	0.0338
7	0	7	0.1429	41	2	9	0.0300
49	3	1	0.1402	53	3	5	0.0280
34	2	2	0.1351	42	2	10	0.0270
20170.1304	43	2		11	0.0246		
8	0	8	0.1250	54	3	6	0.0234
9	0	9	0.1111	44	2	12	0.0225
21	1	5	0.1043	45	2	13	0.0208
10	0	10	0.1000	55	3	7	0.0200
11	0	11	0.0909	46	2	14	0.0193
35	2	3	0.0901	47	2	15	0.0180
22	1	6	0.0870	56	3	8	0.0175
12	0	12	0.0833	57	3	9	0.0156
13	0	13	0.0769	58	3	10	0.0140
23	1	7	0.0745	59	3	11	0.0125
14	0	14	0.0714	60	3	12	0.0117
50	3	2	0.0701	61	3	13	0.0108
36	2	4	0.0676	62	3	14	0.0100
15	0	15	0.0667	63	3	15	0.0093



9.9.3.2 Calculating the relative source resistance

The reference source resistance $R_{S(ref)}$ can be calculated using Equation 6.

$$R_{S(ref)} = \frac{I}{MANT_{GsCfGCW} \cdot \left(\frac{77}{40}\right)^{EXP_{GsCfGCW}}}$$

The reference source resistance ($R_{S(ref)}$) during the modulation phase can be calculated using ModConductance register's $GsCfGMod[5:0]$.

9.9.3.3 Calculating the effective source resistance

Wiring resistance ($R_{S(wire)}$): Wiring and bonding add a constant offset to the driver resistance that is relevant when pins TX1 and TX2 are switched to low-impedance. The additional resistance for pin TX1 ($R_{S(wire)TX1}$) can be set approximately as shown in Equation 7.

$$R_{S(wire)TX1} \approx 500 \text{ m}\Omega$$

Effective resistance (R_{Sx}): The source resistances of the driver transistors (R_{SMaxP} byte) read from the Product Information Field (see Section 9.2.1 on page 13) are measured during the production test with CwConductance register's $GsCfGCW[5:0] = 01h$.

To calculate the driver resistance for a specific value set in $GsCfGMod[5:0]$, use Equation 8.

$$R_{Sx} = R_{S(ref)} \cdot \max(R_{S(wire)TX1}, R_{S(ref)} + R_{S(wire)TX1})$$

9.9.4 Pulse width

The envelope carries the data signal information that is transmitted to the card. It is an encoded data signal based on the Miller code. In addition, each pause of the Miller encoded signal is again encoded as a pulse of a fixed width. The width of the pulse is adjusted using the ModWidth register. The pulse width (t_w) is calculated using Equation 9 where the frequency constant (f_{clk}) = 13.56 MHz.

$$t_w = 2 \frac{ModWidth + 1}{f_c}$$

9.10 Receiver circuitry

The FSV9532 uses an integrated quadrature demodulation circuit enabling it to detect an ISO/IEC 14443 A or ISO/IEC 14443 B compliant subcarrier signal on pin RX.

- **ISO/IEC 14443 A subcarrier signal:** defined as a Manchester coded ASK modulated signal
- **ISO/IEC 14443 B subcarrier signal:** defined as an NRZ-L coded BPSK modulated ISO/IEC 14443 B subcarrier signal



The quadrature demodulator uses two different clocks (Q-clock and I-clock) with a phase-shift of 90° between them. Both resulting subcarrier signals are amplified, filtered and forwarded to the correlation circuitry. The correlation results are evaluated, digitized and then passed to the digital circuitry. Various adjustments can be made to obtain optimum performance for all processing units.

9.10.1 Receiver circuit block diagram

Figure 12 shows the block diagram of the receiver circuit. The receiving process can be broken down in to several steps. Quadrature demodulation of the 13.56 MHz carrier signal is performed. To achieve the optimum performance, automatic Q-clock calibration is recommended (see Section 9.10.2.1 on page 35).

The demodulated signal is amplified by an adjustable amplifier. A correlation circuit calculates the degree of similarity between the expected and the received signal. The BitPhase register enables correlation interval position alignment with the received signal's bit grid. In the evaluation and digitizer circuitry, the valid bits are detected and the digital results are sent to the FIFO buffer. Several tuning steps are possible for this circuit.

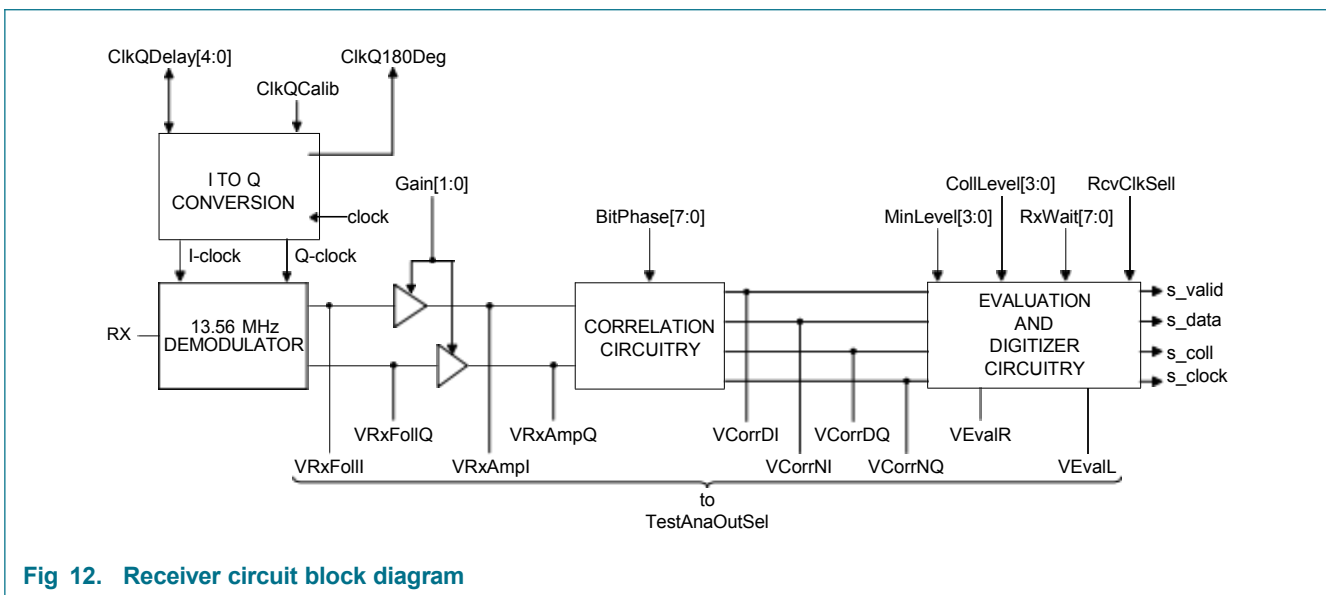

Fig 12. Receiver circuit block diagram

The signal can be observed on its way through the receiver as shown in Figure 12. One signal at a time can be routed to pin AUX using the TestAnaSelect register as described in Section 15.2.2 on page 112.

9.10.2 Receiver operation

In general, the default settings programmed in the StartUp initialization file are suitable for use with the FSV9532 to MIFARE card data communication. However, in some environments specific user settings will achieve better performance.

9.10.2.1 Automatic Q-clock calibration

The quadrature demodulation concept of the receiver generates a phase signal (I-clock) and a 90° phase-shifted quadrature signal (Q-clock). To achieve the optimum demodulator performance, the Q-clock and the I-clock must be phase-shifted by 90°. After the reset phase, a calibration procedure is automatically performed.



Automatic calibration can be set-up to execute at the end of each Transceive command if bit ClkQCalib = logic 0. Setting bit ClkQCalib = logic 1 disables all automatic calibrations except after the reset sequence. Automatic calibration can also be triggered by the software when bit ClkQCalib has a logic 0 to logic 1 transition.

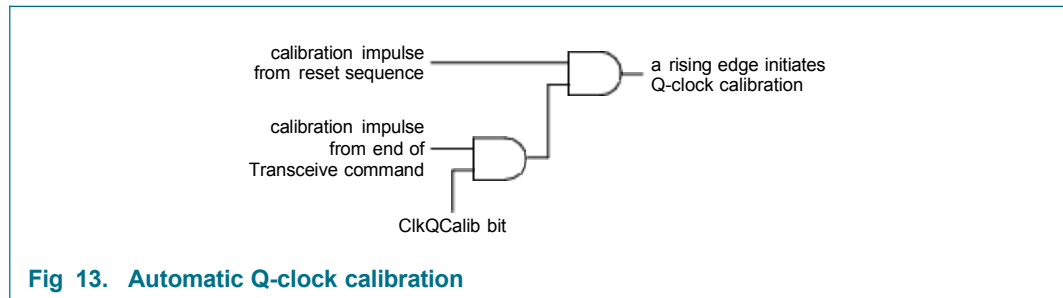

Remark: The duration of the automatic Q-clock calibration is 65 oscillator periods or approximately 4.8 μ s.

The ClockQControl register's ClkQDelay[4:0] value is proportional to the phase-shift between the Q-clock and the I-clock. The ClkQ180Deg status flag bit is set when the phase-shift between the Q-clock and the I-clock is greater than 180°.

Remark:

- The StartUp configuration file enables automatic Q-clock calibration after a reset
- If bit ClkQCalib = logic 1, automatic calibration is not performed. Leaving this bit set to logic 1 can be used to permanently disable automatic calibration.
- It is possible to write data to the ClkQDelay[4:0] bits using the microprocessor. The aim could be to disable automatic calibration and set the delay using the software. Configuring the delay value using the software requires bit ClkQCalib to have been previously set to logic 1 and a time interval of at least 4.8 μ s has elapsed. Each delay value must be written with bit ClkQCalib set to logic 1. If bit ClkQCalib is logic 0, the configured delay value is overwritten by the next automatic calibration interval.

9.10.2.2 Amplifier

The demodulated signal must be amplified by the variable amplifier to achieve the best performance. The gain of the amplifiers can be adjusted using the RxControl1 register Gain[1:0] bits; see Table 29.

Table 29. Gain factors for the internal amplifier

See Table 86 “RxControl1 register bit descriptions” on page 64 for additional information.

Register setting	Gain factor [dB] (simulation results)
00	20
01	24
10	31
11	35



9.10.2.3 Correlation circuitry

The correlation circuitry calculates the degree of matching between the received and an expected signal. The output is a measure of the amplitude of the expected signal in the received signal. This is done for both, the Q and I-channels. The correlator provides two outputs for each of the two input channels, resulting in a total of four output signals.

The correlation circuitry needs the phase information for the incoming card signal for optimum performance. This information is defined for the microprocessor using the BitPhase register. This value defines the phase relationship between the transmitter and receiver clock in multiples of the BitPhase time ($t_{\text{BitPhase}} = 1 / 13.56 \text{ MHz}$).

9.10.2.4 Evaluation and digitizer circuitry

The correlation results are evaluated for each bit-half of the Manchester coded signal. The evaluation and digitizer circuit decides from the signal strengths of both bit-halves, if the current bit is valid

- If the bit is valid, its value is identified
- If the bit is not valid, it is checked to identify if it contains a bit-collision

Select the following levels for optimal using RxThreshold register bits:

- **MinLevel[3:0]:** defines the minimum signal strength of the stronger bit-half's signal which is considered valid.
- **CollLevel[3:0]:** defines the minimum signal strength relative to the amplitude of the stronger half-bit that has to be exceeded by the weaker half-bit of the Manchester coded signal to generate a bit-collision. If the signal's strength is below this value, logic 1 and logic 0 can be determined unequivocally.

After data transmission, the card is not allowed to send its response before a preset time period which is called the frame guard time in the ISO/IEC 14443 standard. The length of this time period is set using the RxWait register's RxWait[7:0] bits. The RxWait register defines when the receiver is switched on after data transmission to the card in multiples of one bit duration.

If bit RcvClkSell is set to logic 1, the I-clock is used to clock the correlator and evaluation circuits. If bit RcvClkSell is set to logic 0, the Q-clock is used.

Remark: It is recommended to use the Q-clock.

9.11 Serial signal switch

The FSV9532 comprises two main blocks:

- **digital circuitry:** comprising the state machines, encoder and decoder logic etc.
- **analog circuitry:** comprising the modulator, antenna drivers, receiver and amplification circuitry

The interface between these two blocks can be configured so that the interface signals are routed to pins MFIN and MFOUT. This makes it possible to connect the analog part of one FSV9532 to the digital part of another device.

The serial signal switch can be used to measure MIFARE and ISO/IEC 14443 A as well as related I-CODE1 and ISO/IEC 15693 signals.



Remark: Pin MFIN can only be accessed at 106 kBd based on ISO/IEC 14443 A. The Manchester signal and the Manchester signal with subcarrier can only be accessed on pin MFOUT at 106 kBd based on ISO/IEC 14443 A.

9.11.1 Serial signal switch block diagram

Figure 14 shows the serial signal switches. Three different switches are implemented in the serial signal switch enabling the FSV9532 to be used in different configurations.

The serial signal switch can also be used to check the transmitted and received data during the design-in phase or for test purposes. Section 15.2.1 on page 110 describes the analog test signals and measurements at the serial signal switch.

Remark: The FSV9504 uses pin name SIGOUT for pin MFOUT. The FSV9532 functionality includes the test modes for the FSV9504 using pin MFOUT.

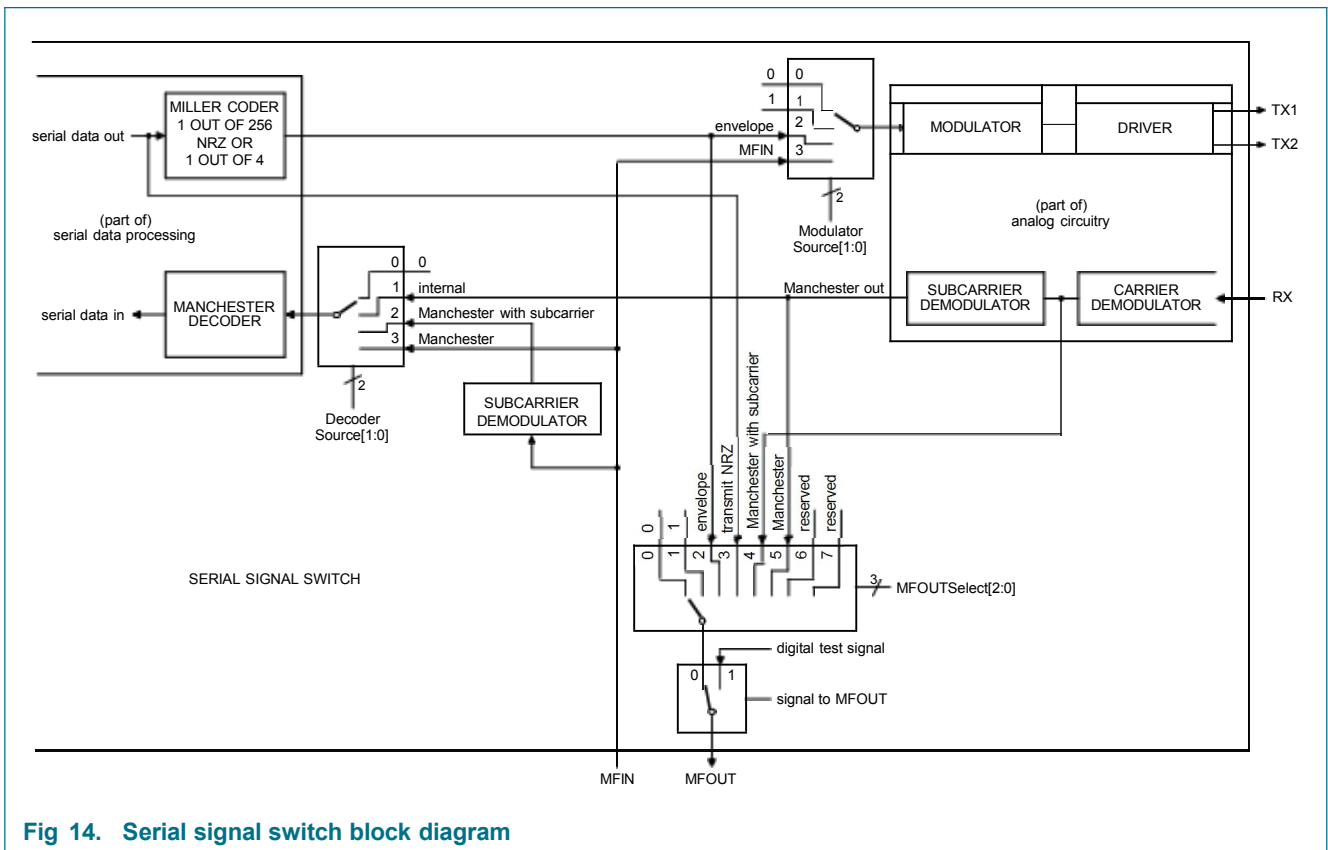

Fig 14. Serial signal switch block diagram

Section 9.11.2, Section 9.11.2.1 and Section 9.11.2.2 describe the relevant registers and settings used to configure and control the serial signal switch.

9.11.2 Serial signal switch registers

The RxControl2 register DecoderSource[1:0] bits define the input signal for the internal Manchester decoder and are described in Table 30.



Table 30. DecoderSource[1:0] values

See [Table 96 on page 67](#) for additional information.

Number	DecoderSource [1:0]	Input signal to decoder
0	00	constant 0
1	01	output of the analog part. This is the default configuration
2	10	direct connection to pin MFIN; expects an 847.5 kHz subcarrier signal modulated by a Manchester encoded signal
3	11	direct connection to pin MFIN; expects a Manchester encoded signal

The TxControl register ModulatorSource[1:0] bits define the signal used to modulate the transmitted 13.56 MHz energy carrier. The modulated signal drives pins TX1 and TX2.

Table 31. ModulatorSource[1:0] values

See [Table 96 on page 67](#) for additional information.

Number	ModulatorSource [1:0]	Input signal to modulator
0	00	constant 0 (energy carrier off on pins TX1 and TX2)
1	01	constant 1 (continuous energy carrier on pins TX1 and TX2)
2	10	modulation signal (envelope) from the internal encoder. This is the default configuration.
3	11	direct connection to MFIN; expects a Miller pulse coded signal

The MFOUTSelect register MFOUTSelect[2:0] bits select the output signal which is to be routed to pin MFOUT.

Table 32. MFOUTSelect[2:0] values

See [Table 110 on page 70](#) for additional information.

Number	MFOUTSelect [2:0]	Signal routed to pin MFOUT
0	000	constant LOW
1	001	constant HIGH
2	010	modulation signal (envelope) from the internal encoder
3	011	serial data stream to be transmitted; the same as for MFOUTSelect[2:0] = 001 but not encoded by the selected pulse encoder
4	100	output signal of the receiver circuit; card modulation signal regenerated and delayed
5	101	output signal of the subcarrier demodulator; Manchester coded card signal
6	110	reserved
7	111	reserved

To use the MFOUTSelect[2:0] bits, the TestDigiSelect register SignalToMFOUT bit must be logic 0.

9.11.2.1 Active antenna concept

The FSV9532 analog and digital circuitry is accessed using pins MFIN and MFOUT. [Table 33](#) lists the required settings.



Table 33. Register settings to enable use of the analog circuitry

Register	Number ^[1]	Signal	FSV9532 pin
Analog circuitry settings			
ModulatorSource	3	Miller pulse encoded	MFIN
MFOUTSelect	4	Manchester encoded with subcarrier	MFOUT
DecoderSource	X	-	-
Digital circuitry settings			
ModulatorSource	X	-	-
MFOUTSelect	2	Miller pulse encoded	MFOUT
DecoderSource	2	Manchester encoded with subcarrier	MFIN

[1] The number column refers to the value in the number column of [Table 30](#), [Table 31](#) and [Table 32](#).

Two FSV9532 devices configured as described in [Table 33](#) can be connected to each other using pins MFOUT and MFIN.

Remark: The active antenna concept can only be used at 106 kBd based on ISO/IEC 14443 A.

9.11.2.2 Driving both RF parts

It is possible to connect both passive and active antennas to a single IC. The passive antenna pins TX1, TX2 and RX are connected using the appropriate filter and matching circuit. At the same time an active antenna is connected to pins MFOUT and MFIN. In this configuration, two RF parts can be driven, one after another, by one microprocessor.

9.12 MIFARE higher baud rates

The MIFARE system is specified with a fixed baud rate of 106 kBd for communication on the RF interface. The current version of ISO/IEC 14443 A also defines 106 kBd for the initial phase of a communication between Proximity Integrated Circuit Cards (PICC) and Proximity Coupling Devices (PCD).

To cover requirements of large data transmissions and to speed up terminal to card communication, the FSV9532 supports communication at MIFARE higher baud rates in combination with a microcontroller IC such as the MIFARE ProX.

Table 34. MIFARE higher baud rates

Communication direction	Baud rates (kBd)
FSV9532 based PCD → microcontroller PICC supporting higher baud rates	106, 212, 424
Microcontroller PICC supporting higher baud rates → FSV9532 based PCD	106, 212, 424

The MIFARE higher baud rates concept is described in the application note: *MIFARE Implementation of Higher Baud rates* [Ref. 5](#). This application covers the integration of the MIFARE higher baud rates communication concept in current applications.



9.13 ISO/IEC 14443 B communication scheme

The international standard ISO/IEC 14443 covers two communication schemes; ISO/IEC 14443 A and ISO/IEC 14443 B. The FSV9532 reader IC fully supports both ISO/IEC 14443 variants.

Table 35 describes the registers and flags covered by the ISO/IEC 14443 B communication protocol.

Table 35. ISO/IEC 14443 B registers and flags

Flag	Register	Bit	Register address
CharSpacing[2:0]	TypeBFraming	4 to 2	17h
CoderRate[2:0]	CoderControl	5 to 3	14h
EOFWidth	TypeBFraming	5	17h
FilterAmpDet	BPSKDemControl	4	1Dh
Force100ASK	TxControl	4	11h
GsCfgCW[5:0]	CwConductance	5 to 0	12h
GsCfgMod[5:0]	ModConductance	5 to 0	13h
MinLevel[3:0]	RxThreshold	7 to 4	1Ch
NoTxEOF	TypeBFraming	6	17h
NoTxSOF	TypeBFraming	7	17h
NoRxEGT	BPSKDemControl	6	1Dh
NoRxEOF	BPSKDemControl	5	1Dh
NoRxSOF	BPSKDemControl	7	1Dh
RxCoding	DecoderControl	0	1Ah
RxFraming[1:0]	DecoderControl	4 to 3	1Ah
SOFWidth[1:0]	TypeBFraming	1 to 0	17h
SubCPulses[2:0]	RxControl1	7 to 5	19h
TauB[1:0]	BPSKDemControl	1 to 0	1Dh
TauD[1:0]	BPSKDemControl	3 to 2	1Dh
TxCoding[2:0]	CoderControl	2 to 0	14h

As reference documentation, the international standard *ISO/IEC 14443 Identification cards - Contactless integrated circuit(s) cards - Proximity cards, part 1-4* (Ref. 4) can be used.



9.14 MIFARE authentication and Crypto1

The security algorithm used in the MIFARE products is called Crypto1. It is based on a proprietary stream cipher with a 48-bit key length. To access data on MIFARE cards, knowledge of the key format is needed. The correct key must be available in the FSV9532 to enable successful card authentication and access to the card's data stored in the EEPROM.

After a card is selected as defined in ISO/IEC 14443 A standard, the user can continue with the MIFARE protocol. It is mandatory that card authentication is performed.

Crypto1 authentication is a 3-pass authentication which is automatically performed when the Authent1 and Authent2 commands are executed (see [Section 11.7.3 on page 98](#) and [Section 11.7.4 on page 98](#)).

During the card authentication procedure, the security algorithm is initialized. After a successful authentication, communication with the MIFARE card is encrypted.

9.14.1 Crypto1 key handling

On execution of the authentication command, the FSV9532 reads the key from the key buffer. The key is always read from the key buffer and ensures Crypto1 authentication commands do not require addressing of a key. The user must ensure the correct key is prepared in the key buffer before triggering card authentication.

The key buffer can be loaded from:

- the EEPROM using the LoadKeyE2 command (see [Section 11.7.1 on page 97](#))
- the microprocessor's FIFO buffer using the LoadKey command (see [Section 11.7.2 on page 97](#)). This is shown in [Figure 15](#).

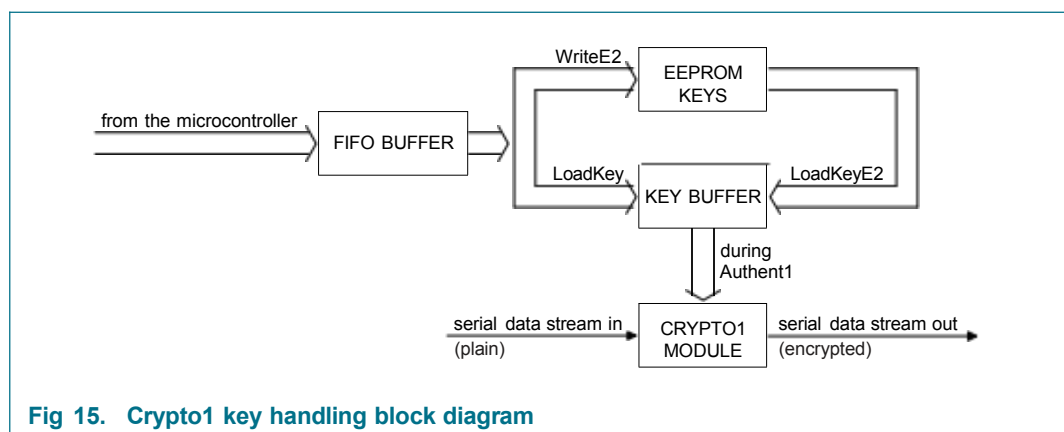

Fig 15. Crypto1 key handling block diagram



9.14.2 Authentication procedure

The Crypto1 security algorithm enables authentication of MIFARE cards. To obtain valid authentication, the correct key has to be available in the key buffer of the FSV9532. This can be ensured as follows:

1. Load the internal key buffer by using the LoadKeyE2 (see [Section 11.7.1 on page 97](#)) or the LoadKey (see [Section 11.7.2 on page 97](#)) commands.
2. Start the Authent1 command (see [Section 11.7.3 on page 98](#)). When finished, check the error flags to obtain the command execution status.
3. Start the Authent2 command (see [Section 11.7.4 on page 98](#)). When finished, check the error flags and bit Crypto1On to obtain the command execution status.

10. FSV9532 registers

10.1 Register addressing modes

Three methods can be used to operate the FSV9532:

- initiating functions and controlling data by executing commands
- configuring the functional operation using a set of configuration bits
- monitoring the state of the FSV9532 by reading status flags

The commands, configuration bits and flags are accessed using the microprocessor interface. The FSV9532 can internally address 64 registers using six address lines.

10.1.1 Page registers

The FSV9532 register set is segmented into eight pages contain eight registers each. A Page register can always be addressed, irrespective of which page is currently selected.

10.1.2 Dedicated address bus

When using the FSV9532 with the dedicated address bus, the microprocessor defines three address lines using address pins A0, A1 and A2. This enables addressing within a page. To switch between registers in different pages a paging mechanism needs to be used.

[Table 36](#) shows how the register address is assembled.

Table 36. Dedicated address bus: assembling the register address

Register bit: UsePageSelect	Register address					
1	PageSelect2	PageSelect1	PageSelect0	A2	A1	A0

10.1.3 Multiplexed address bus

The microprocessor may define all six address lines at once using the FSV9532 with a multiplexed address bus. In this case either the paging mechanism or linear addressing can be used.

[Table 37](#) shows how the register address is assembled.



Table 37. Multiplexed address bus: assembling the register address

Multiplexed address bus type	UsePage Select	Register address					
		PageSelect2	PageSelect1	PageSelect0	AD2	AD1	AD0
Paging mode	1	PageSelect2	PageSelect1	PageSelect0	AD2	AD1	AD0
Linear addressing	0	AD5	AD4	AD3	AD2	AD1	AD0

10.2 Register bit behavior

Bits and flags for different registers behave differently, depending on their functions. In principle, bits with same behavior are grouped in common registers. [Table 38](#) describes the function of the Access column in the register tables.

Table 38. Behavior and designation of register bits

Abbreviation	Behavior	Description
R/W	read and write	These bits can be read and written by the microprocessor. Since they are only used for control, their content is not influenced by internal state machines. Example: TimerReload register may be read and written by the microprocessor. It will also be read by internal state machines but never changed by them.
D	dynamic	These bits can be read and written by the microprocessor. Nevertheless, they may also be written automatically by internal state machines. Example: the Command register changes its value automatically after the execution of the command.
R	read only	These registers hold flags which have a value determined by internal states only. Example: the ErrorFlag register cannot be written externally but shows internal states.
W	write only	These registers are used for control only. They may be written by the microprocessor but cannot be read. Reading these registers returns an undefined value. Example: The TestAnaSelect register is used to determine the signal on pin AUX however, it is not possible to read its content.



10.3 Register overview

Table 39. FSV9532 register overview

Sub address (Hex)	Register name	Function	Refer to
Page 0: Command and status			
00h	Page	selects the page register	Table 41 on page 50
01h	Command	starts and stops command execution	Table 43 on page 50
02h	FIFOData	input and output of 64-byte FIFO buffer	Table 45 on page 51
03h	PrimaryStatus	receiver and transmitter and FIFO buffer status flags	Table 47 on page 51
04h	FIFOLength	number of bytes buffered in the FIFO buffer	Table 49 on page 52
05h	SecondaryStatus	secondary status flags	Table 51 on page 53
06h	InterruptEn	enable and disable interrupt request control bits	Table 53 on page 53
07h	InterruptRq	interrupt request flags	Table 55 on page 54
Page 1: Control and status			
08h	Page	selects the page register	Table 41 on page 50
09h	Control	control flags for timer unit, power saving etc	Table 57 on page 55
0Ah	ErrorFlag	show the error status of the last command executed	Table 59 on page 55
0Bh	CollPos	bit position of the first bit-collision detected on the RF interface	Table 61 on page 56
0Ch	TimerValue	value of the timer	Table 63 on page 57
0Dh	CRCResultLSB	LSB of the CRC coprocessor register	Table 65 on page 57
0Eh	CRCResultMSB	MSB of the CRC coprocessor register	Table 67 on page 57
0Fh	BitFraming	adjustments for bit oriented frames	Table 69 on page 58
Page 2: Transmitter and coder control			
10h	Page	selects the page register	Table 41 on page 50
11h	TxControl	controls the operation of the antenna driver pins TX1 and TX2	Table 71 on page 59
12h	CwConductance	selects the conductance of the antenna driver pins TX1 and TX2	Table 73 on page 60
13h	ModConductance	defines the driver output conductance	Table 75 on page 60
14h	CoderControl	sets the clock frequency and the encoding	Table 77 on page 61
15h	ModWidth	selects the modulation pulse width	Table 79 on page 62
16h	ModWidthSOF	selects the SOF pulse-width modulation (I-CODE1 fast mode)	Table 81 on page 62
17h	TypeBFraming	defines the framing for ISO/IEC 14443 B communication	Table 83 on page 63
Page 3: Receiver and decoder control			
18	Page	selects the page register	Table 41 on page 50
19	RxControl1	controls receiver behavior	Table 85 on page 64
1A	DecoderControl	controls decoder behavior	Table 87 on page 65
1B	BitPhase	selects the bit-phase between transmitter and receiver clock	Table 89 on page 65
1C	RxThreshold	selects thresholds for the bit decoder	Table 91 on page 66
1D	BPSKDemControl	controls BPSK receiver behavior	Table 93 on page 66
1Eh	RxControl2	controls decoder and defines the receiver input source	Table 95 on page 67
1Fh	ClockQControl	clock control for the 90° phase-shifted Q-channel clock	Table 97 on page 67



Table 39. FSV9532 register overview

Sub address (Hex)	Register name	Function	Refer to
Page 4: RF Timing and channel redundancy			
20h	Page	selects the page register	Table 41 on page 50
21h	RxWait	selects the interval after transmission before the receiver starts	Table 99 on page 68
22h	ChannelRedundancy	selects the method and mode used to check data integrity on the RF channel	Table 101 on page 68
23h	CRCPresetLSB	preset LSB value for the CRC register	Table 103 on page 69
24h	CRCPresetMSB	preset MSB value for the CRC register	Table 105 on page 69
25h	TimeSlotPeriod	selects the time between automatically transmitted frames	Table 107 on page 69
26h	MFOUSelect	selects internal signal applied to pin MFOU, includes the MSB of value TimeSlotPeriod; see Table 107 on page 69	Table 109 on page 70
27h	PreSet27	these values are not changed	Table 111 on page 70
Page 5: FIFO, timer and IRQ pin configuration			
28h	Page	selects the page register	Table 41 on page 50
29h	FIFOLevel	defines the FIFO buffer overflow and underflow warning levels	Table 49 on page 52
2Ah	TimerClock	selects the timer clock divider	Table 114 on page 71
2Bh	TimerControl	selects the timer start and stop conditions	Table 116 on page 72
2Ch	TimerReload	defines the timer preset value	Table 118 on page 72
2Dh	IRQPinConfig	configures pin IRQ output stage	Table 120 on page 73
2Eh	PreSet2E	these values are not changed	Table 122 on page 73
2Fh	PreSet2F	these values are not changed	Table 123 on page 73
Page 6: reserved registers			
30h	Page	selects the page register	Table 41 on page 50
31h	reserved	reserved	Table 124 on page 73
32h	reserved	reserved	
33h	reserved	reserved	
34h	reserved	reserved	
35h	reserved	reserved	
36h	reserved	reserved	
37h	reserved	reserved	
Page 7: Test control			
38h	Page	selects the page register	Table 41 on page 50
39h	reserved	reserved	Table 125 on page 74
3Ah	TestAnaSelect	selects analog test mode	Table 126 on page 74
3Bh	reserved	reserved	Table 128 on page 75
3Ch	reserved	reserved	Table 129 on page 75
3Dh	TestDigiSelect	selects digital test mode	Table 130 on page 75
3Eh	reserved	reserved	Table 132 on page 76
3Fh	reserved	reserved	



10.4 FSV9532 register flags overview

Table 40. FSV9532 register flags overview

Flag(s)	Register	Bit	Address
AccessErr	ErrorFlag	5	0Ah
BitPhase[7:0]	BitPhase	7 to 0	1Bh
CharSpacing[2:0]	TypeBFraming	4 to 2	17h,
ClkQ180Deg	ClockQControl	7	1Fh
ClkQCalib	ClockQControl	6	1Fh
ClkQDelay[4:0]	ClockQControl	4 to 0	1Fh
CoderRate[2:0]	CoderControl	5 to 3	14h
CollErr	ErrorFlag	0	0Ah
CollLevel[3:0]	RxThreshold	3 to 0	1Ch
CollPos[7:0]	CollPos	7 to 0	0Bh
Command[5:0]	Command	5 to 0	01h
CRC3309	ChannelRedundancy	5	22h
CRC8	ChannelRedundancy	4	22h
CRCErr	ErrorFlag	3	0Ah
CRCPresetLSB[7:0]	CRCPresetLSB	7 to 0	23h
CRCPresetMSB[7:0]	CRCPresetMSB	7 to 0	24h
CRCReady	SecondaryStatus	5	05h
CRCResultMSB[7:0]	CRCResultMSB	7 to 0	0Eh
CRCResultLSB[7:0]	CRCResultLSB	7 to 0	0Dh
Crypto1On	Control	3	09h
DecoderSource[1:0]	RxControl2	1 to 0	1Eh
E2Ready	SecondaryStatus	6	05h
EOFWidth	TypeBFraming	5	17h
Err	PrimaryStatus	2	03h
FIFOData[7:0]	FIFOData	7 to 0	02h
FIFOLength[6:0]	FIFOLength	6 to 0	04h
FIFOovfl	ErrorFlag	4	0Ah
FilterAmpDet	BPSKDemControl	4	1Dh
FlushFIFO	Control	0	09h
Force100ASK	TxControl	4	11h
FramingErr	ErrorFlag	2	0Ah
Gain[1:0]	RxControl1	1 to 0	19h
GsCfgCW[5:0]	CwConductance	5 to 0	12h
GsCfgMod[5:0]	ModConductance	5 to 0	13h
HiAlert	PrimaryStatus	1	03h
HiAlertIEn	InterruptEn	1	06h
HiAlertIRq	InterruptRq	1	07h
IdleIEn	InterruptEn	2	06h
IdleIRq	InterruptRq	2	07h



Table 40. FSV9532 register flags overview

Flag(s)	Register	Bit	Address
IFDetectBusy	Command	7	01h
IRq	PrimaryStatus	3	03h
IRQInv	IRQPinConfig	1	2Dh
IRQPushPull	IRQPinConfig	0	2Dh
ISO Selection[1:0]	RxControl1	4 to 3	19h
KeyErr	ErrorFlag	6	0Ah
LoAlert	PrimaryStatus	0	03h
LoAlertEn	InterruptEn	0	06h
LoAlertIRq	InterruptRq	0	07h
LPOff	RxControl1	2	19h
MFOUTSelect[2:0]	MFOUTSelect	2 to 0	26h
MinLevel[3:0]	RxThreshold	7 to 4	1Ch
ModemState[2:0]	PrimaryStatus	6 to 4	03h
ModulatorSource[1:0]	TxControl	6 to 5	11h
ModWidth[7:0]	ModWidth	7 to 0	15h
NoRxEGT	BPSKDemControl	6	1Dh
NoRxEOF	BPSKDemControl	5	1Dh
NoRxSOF	BPSKDemControl	7	1Dh
NoTxEOF	TypeBFraming	6	17h
NoTxSOF	TypeBFraming	7	17h
PageSelect[2:0]	Page	2 to 0	00h, 08h, 10h, 18h, 20h, 28h, 30h and 38h
ParityEn	ChannelRedundancy	0	22h
ParityErr	ErrorFlag	1	0Ah
ParityOdd	ChannelRedundancy	1	22h
PowerDown	Control	4	09h
RcvClkSell	RxControl2	7	1Eh
RxAlign[2:0]	BitFraming	6 to 4	0Fh
RxAutoPD	RxControl2	6	1Eh
RxCRCEn	ChannelRedundancy	3	22h
RxCoding	DecoderControl	0	1Ah
RxFraming[1:0]	DecoderControl	4 to 3	1Ah
RxIEn	InterruptEn	3	06h
RxIRq	InterruptRq	3	07h
RxLastBits[2:0]	SecondaryStatus	2 to 0	05h
RxMultiple	DecoderControl	6	1Ah
RxWait[7:0]	RxWait	7 to 0	21h
SetIEn	InterruptEn	7	06h
SetIRq	InterruptRq	7	07h
SignalToMFOUT	TestDigiSelect	7	3Dh
SOFWidth[1:0]	TypeBFraming	1 to 0	17h



Table 40. FSV9532 register flags overview

Flag(s)	Register	Bit	Address
StandBy	Control	5	09h
SubCPulses[2:0]	RxControl1	7 to 5	19h
TauB[1:0]	BPSKDemControl	1 to 0	1Dh
TauD[1:0]	BPSKDemControl	3 to 2	1Dh
TAutoRestart	TimerClock	5	2Ah
TestAnaOutSel[4:0]	TestAnaSelect	3 to 0	3Ah
TestDigiSignalSel[6:0]	TestDigiSelect	6 to 0	3Dh
TimerIEn	InterruptEn	5	06h
TimerIRq	InterruptRq	5	07h
TimerValue[7:0]	TimerValue	7 to 0	0Ch
TimeSlotPeriod[7:0]	TimeSlotPeriod	7 to 0	25h
TimeSlotPeriodMSB	MFOUTSelect	4	26h
TPreScaler[4:0]	TimerClock	4 to 0	2Ah
TReloadValue[7:0]	TimerReload	7 to 0	2Ch
TRunning	SecondaryStatus	7	05h
TStartTxBegin	TimerControl	0	2Bh
TStartTxEnd	TimerControl	1	2Bh
TStartNow	Control	1	09h
TStopRxBegin	TimerControl	2	2Bh
TStopRxEnd	TimerControl	3	2Bh
TStopNow	Control	2	09h
TX1RFEn	TxControl	0	11h
TX2Cw	TxControl	3	11h
TX2Inv	TxControl	3	11h
TX2RFEn	TxControl	1	11h
TxCoding[2:0]	CoderControl	2 to 0	14h
TxCRCEn	ChannelRedundancy	2	22h
TxIEn	InterruptEn	4	06h
TxIRq	InterruptRq	4	07h
TxLastBits[2:0]	BitFraming	2 to 0	0Fh
UsePageSelect	Page	7	00h, 08h, 10h, 18h, 20h, 28h, 30h and 38h
WaterLevel[5:0]	FIFOLevel	5 to 0	29h
ZeroAfterColl	DecoderControl	7	1Ah, bit 5



10.5 Register descriptions

10.5.1 Page 0: Command and status

10.5.1.1 Page register

Selects the page register.

**Table 41. Page register (address: 00h, 08h, 10h, 18h, 20h, 28h, 30h, 38h)
reset value: 1000 0000b, 80h bit allocation**

Bit	7	6	5	4	3	2	1	0
Symbol	UsePageSelect	0000			PageSelect[2:0]			
Access	R/W	R/W			R/W	R/W	R/W	

Table 42. Page register bit descriptions

Bit	Symbol	Value	Description
7	UsePageSelect	1	the value of PageSelect[2:0] is used as the register address A5, A4, and A3. The LSBs of the register address are defined using the address pins or the internal address latch, respectively.
		0	the complete content of the internal address latch defines the register address. The address pins are used as described in Table 5 on page 8 .
6 to 3	0000	-	reserved
2 to 0	PageSelect[2:0]	-	when UsePageSelect = logic 1, the value of PageSelect is used to specify the register page (A5, A4 and A3 of the register address)

10.5.1.2 Command register

Starts and stops the command execution.

Table 43. Command register (address: 01h) reset value: x000 0000b, x0h bit allocation

Bit	7	6	5	4	3	2	1	0
Symbol	IFDetectBusy	0	Command[5:0]					
Access	R	R	D					

Table 44. Command register bit descriptions

Bit	Symbol	Value	Description
7	IFDetectBusy	-	shows the status of interface detection logic
		0	interface detection finished successfully
		1	interface detection ongoing
6	0	-	reserved
5 to 0	Command[5:0]	-	activates a command based on the Command code. Reading this register shows which command is being executed.



10.5.1.3 FIFOData register

Input and output of the 64 byte FIFO buffer.

Table 45. FIFOData register (address: 02h) reset value: xxxx xxxxb, 05h bit allocation

Bit	7	6	5	4	3	2	1	0
Symbol	FIFOData[7:0]							
Access	D							

Table 46. FIFOData register bit descriptions

Bit	Symbol	Description
7 to 0	FIFOData[7:0]	data input and output port for the internal 64-byte FIFO buffer. The FIFO buffer acts as a parallel in to parallel out converter for all data streams.

10.5.1.4 PrimaryStatus register

Bits relating to receiver, transmitter and FIFO buffer status flags.

Table 47. PrimaryStatus register (address: 03h) reset value: 0000 0101b, 05h bit allocation

Bit	7	6	5	4	3	2	1	0
Symbol	0	ModemState[2:0]			IRq	Err	HiAlert	LoAlert
Access	R	R			R	R	R	R

Table 48. PrimaryStatus register bit descriptions

Bit	Symbol	Value	Status	Description
7	0	-		reserved
6 to 4	ModemState[2:0]			shows the state of the transmitter and receiver state machines:
		000	Idle	neither the transmitter or receiver are operating; neither of them are started or have input data
		001	TxSOF	transmit start of frame pattern
		010	TxData	transmit data from the FIFO buffer (or redundancy CRC check bits)
		011	TxEof	transmit End Of Frame (EOF) pattern
		100	GoToRx1	intermediate state 1; receiver starts
			GoToRx2	intermediate state 2; receiver finishes
		101	PrepareRx	waiting until the RxWait register time period expires
		110	AwaitingRx	receiver activated; waiting for an input signal on pin RX
111	Receiving	receiving data		
3	IRq	-		shows any interrupt source requesting attention based on the InterruptEn register flag settings



Table 48. PrimaryStatus register bit descriptions

Bit	Symbol	Value	Status	Description
2	Err	1		any error flag in the ErrorFlag register is set
1	HiAlert	1		the alert level for the number of bytes in the FIFO buffer (FIFOLength[6:0]) is: $HiAlert = 64 - FIFOLength \leq WaterLevel$ otherwise value = logic 0 Example: FIFOLength = 60, WaterLevel = 4 then HiAlert = logic 1 FIFOLength = 59, WaterLevel = 4 then HiAlert = logic 0
0	LoAlert	1		the alert level for number of bytes in the FIFO buffer (FIFOLength[6:0]) is: $LoAlert = FIFOLength \leq WaterLevel$ otherwise value = logic 0 Example: FIFOLength = 4, WaterLevel = 4 then LoAlert = logic 1 FIFOLength = 5, WaterLevel = 4 then LoAlert = logic 0

10.5.1.5 FIFOLength register

Number of bytes in the FIFO buffer.

Table 49. FIFOLength register (address: 04h) reset value: 0000 0000b, 00h bit allocation

Bit	7	6	5	4	3	2	1	0
Symbol	0	FIFOLength[6:0]						
Access	R	R						

Table 50. FIFOLength bit descriptions

Bit	Symbol	Description
7	0	reserved
6 to 0	FIFOLength[6:0]	gives the number of bytes stored in the FIFO buffer. Writing increments the FIFOLength register value while reading decrements the FIFOLength register value



10.5.1.6 SecondaryStatus register

Various secondary status flags.

Table 51. SecondaryStatus register (address: 05h) reset value: 01100 000b, 60h bit allocation

Bit	7	6	5	4	3	2	1	0
Symbol	TRunning	E2Ready	CRCReady	00		RxLastBits[2:0]		
Access	R	R	R	R		R		

Table 52. SecondaryStatus register bit descriptions

Bit	Symbol	Value	Description
7	TRunning	1	the timer unit is running and the counter decrements the TimerValue register on the next timer clock cycle
		0	the timer unit is not running
6	E2Ready	1	EEPROM programming is finished
		0	EEPROM programming is ongoing
5	CRCReady	1	CRC calculation is finished
		0	CRC calculation is ongoing
4 to 3	00	-	reserved
2 to 0	RxLastBits [2:0]	-	shows the number of valid bits in the last received byte. If zero, the whole byte is valid

10.5.1.7 InterruptEn register

Control bits to enable and disable passing of interrupt requests.

Table 53. InterruptEn register (address: 06h) reset value: 0000 0000b, 00h bit allocation

Bit	7	6	5	4	3	2	1	0
Symbol	SetIEn	0	TimerIEn	TxIEn	RxIEn	IdleIEn	HiAlertIEn	LoAlertIEn
Access	W	R/W	R/W	R/W	R/W	R/W	R/W	R/W

Table 54. InterruptEn register bit descriptions

Bit	Symbol	Value	Description
7	SetIEn	1	indicates that the marked bits in the InterruptEn register are set
		0	clears the marked bits
6	0	-	reserved
5	TimerIEn	-	sends the TimerIRq timer interrupt request to pin IRQ^[1]
4	TxIEn	-	sends the TxIRq transmitter interrupt request to pin IRQ^[1]
3	RxIEn	-	sends the RxIRq receiver interrupt request to pin IRQ^[1]
2	IdleIEn	-	sends the IdleIRq idle interrupt request to pin IRQ^[1]
1	HiAlertIEn	-	sends the HiAlertIRq high alert interrupt request to pin IRQ^[1]
0	LoAlertIEn	-	sends the LoAlertIRq low alert interrupt request to pin IRQ^[1]

[1] This bit can only be set or cleared using bit SetIEn.



10.5.1.8 InterruptRq register

Interrupt request flags.

Table 55. InterruptRq register (address: 07h) reset value: 0000 0000b, 00h bit allocation

Bit	7	6	5	4	3	2	1	0
Symbol	SetIRq	0	TimerIRq	TxIRq	RxIRq	IdleIRq	HiAlertIRq	LoAlertIRq
Access	W	R/W	D	D	D	D	D	D

Table 56. InterruptRq register bit descriptions

Bit	Symbol	Value	Description
7	SetIRq	1	sets the marked bits in the InterruptRq register
		0	clears the marked bits in the InterruptRq register
6	0	-	reserved
5	TimerIRq	1	timer decrements the TimerValue register to zero
		0	timer decrements are still greater than zero
4	TxIRq	1	TxIRq is set to logic 1 if one of the following events occurs: Transceive command; all data transmitted Authent1 and Authent2 commands; all data transmitted WriteE2 command; all data is programmed CalcCRC command; all data is processed
		0	when not acted on by Transceive, Authent1, Authent2, WriteE2 or CalcCRC commands
3	RxIRq	1	the receiver terminates
		0	reception still ongoing
2	IdleIRq	1	command terminates correctly. For example; when the Command register changes its value from any command to the Idle command. If an unknown command is started the IdleIRq bit is set. Microprocessor start-up of the Idle command does not set the IdleIRq bit.
		0	IdleIRq = logic 0 in all other instances
1	HiAlertIRq	1	PrimaryStatus register HiAlert bit is set ^[1]
		0	PrimaryStatus register HiAlert bit is not set
0	LoAlertIRq	1	PrimaryStatus register LoAlert bit is set ^[1]
		0	PrimaryStatus register LoAlert bit is not set

[1] PrimaryStatus register Bit HiAlertIRq stores this event and it can only be reset using bit SetIRq.



10.5.2 Page 1: Control and status

10.5.2.1 Page register

Selects the page register; see [Section 10.5.1.1 “Page register”](#) on page 50.

10.5.2.2 Control register

Various control flags, for timer, power saving, etc.

Table 57. Control register (address: 09h) reset value: 0000 0000b, 00h bit allocation

Bit	7	6	5	4	3	2	1	0
Symbol	00		StandBy	PowerDown	Crypto1On	TStopNow	TStartNow	FlushFIFO
Access	R/W		D	D	D	D	D	D

Table 58. Control register bit descriptions

Bit	Symbol	Value	Description
7 to 6	00	-	reserved
5	StandBy	1	activates Standby mode. The current consuming blocks are switched off but the clock keeps running
4	PowerDown	1	activates Power-down mode. The current consuming blocks are switched off including the clock
3	Crypto1On	1	Crypto1 unit is switched on and all data communication with the card is encrypted. This bit can only be set to logic 1 by successful execution of the Authent2 command
		0	Crypto1 unit is switched off. All data communication with the card is unencrypted (plain)
2	TStopNow	1	immediately stops the timer. Reading this bit always returns logic 0
1	TStartNow	1	immediately starts the timer. Reading this bit will always returns logic 0
0	FlushFIFO	1	immediately clears the internal FIFO buffer's read and write pointer, the FIFOLength[6:0] bits are set to logic 0 and the FIFOovfl flag. Reading this bit always returns logic 0

10.5.2.3 ErrorFlag register

Error flags show the error status of the last executed command.

Table 59. ErrorFlag register (address: 0Ah) reset value: 0100 0000b, 40h bit allocation

Bit	7	6	5	4	3	2	1	0
Symbol	0	KeyErr	AccessErr	FIFOovfl	CRCErr	FramingErr	ParityErr	CollErr
Access	R	R	R	R	R	R	R	R

Table 60. ErrorFlag register bit descriptions

Bit	Symbol	Value	Description
7	0	-	reserved
6	KeyErr	1	set when the LoadKeyE2 or LoadKey command recognize that the input data is not encoded based on the Key format definition
		0	set when the LoadKeyE2 or the LoadKey command starts



Table 60. ErrorFlag register bit descriptions

Bit	Symbol	Value	Description
5	AccessErr	1	set when the access rights to the EEPROM are violated
		0	set when an EEPROM related command starts
4	FIFOovfl	1	set when the microprocessor or FSV9532 internal state machine (e.g. receiver) tries to write data to the FIFO buffer when it is full
3	CRCErr	1	set when RxCRCEn is set and the CRC fails
		0	automatically set during the PrepareRx state in the receiver start phase
2	FramingErr	1	set when the SOF is incorrect
		0	automatically set during the PrepareRx state in the receiver start phase
1	ParityErr	1	set when the parity check fails
		0	automatically set during the PrepareRx state in the receiver start phase
0	CollErr	1	set when a bit-collision is detected ^[1]
		0	automatically set during the PrepareRx state in the receiver start phase ^[1]

[1] Only valid for communication using ISO/IEC 14443 A.

10.5.2.4 CollPos register

Bit position of the first bit-collision detected on the RF interface.

Table 61. CollPos register (address: 0Bh) reset value: 0000 0000b, 00h bit allocation

Bit	7	6	5	4	3	2	1	0
Symbol	CollPos[7:0]							
Access	R							

Table 62. CollPos register bit descriptions

Bit	Symbol	Description
7 to 0	CollPos[7:0]	<p>this register shows the bit position of the first detected collision in a received frame.</p> <p>Example:</p> <p>00h indicates a bit collision in the start bit</p> <p>01h indicates a bit collision in the 1st bit</p> <p>...</p> <p>08h indicates a bit collision in the 8th bit</p>

Remark: A bit collision is not indicated in the CollPos register when using the ISO/IEC 14443 B protocol standard.



10.5.2.5 TimerValue register

Value of the timer.

Table 63. TimerValue register (address: 0Ch) reset value: xxxx xxxxb, xxh bit allocation

Bit	7	6	5	4	3	2	1	0
Symbol	TimerValue[7:0]							
Access	R							

Table 64. TimerValue register bit descriptions

Bit	Symbol	Description
7 to 0	TimerValue[7:0]	this register shows the timer counter value

10.5.2.6 CRCResultLSB register

LSB of the CRC coprocessor register.

Table 65. CRCResultLSB register (address: 0Dh) reset value: xxxx xxxxb, xxh bit allocation

Bit	7	6	5	4	3	2	1	0
Symbol	CRCResultLSB[7:0]							
Access	R							

Table 66. CRCResultLSB register bit descriptions

Bit	Symbol	Description
7 to 0	CRCResultLSB[7:0]	gives the CRC register's least significant byte value; only valid if CRCReady = logic 1

10.5.2.7 CRCResultMSB register

MSB of the CRC coprocessor register.

Table 67. CRCResultMSB register (address: 0Eh) reset value: xxxx xxxxb, xxh bit allocation

Bit	7	6	5	4	3	2	1	0
Symbol	CRCResultMSB[7:0]							
Access	R							

Table 68. CRCResultMSB register bit descriptions

Bit	Symbol	Description
7 to 0	CRCResultMSB[7:0]	gives the CRC register's most significant byte value; only valid if CRCReady = logic 1. The register's value is undefined for 8-bit CRC calculation.



10.5.2.8 BitFraming register

Adjustments for bit oriented frames.

Table 69. BitFraming register (address: 0Fh) reset value: 0000 0000b, 00h bit allocation

Bit	7	6	5	4	3	2	1	0
Symbol	0	RxAlign[2:0]			0	TxLastBits[2:0]		
Access	R/W	D			R/W	D		

Table 70. BitFraming register bit descriptions

Bit	Symbol	Value	Description
7	0	-	reserved
6 to 4	RxAlign[2:0]		defines the bit position for the first bit received to be stored in the FIFO buffer. Additional received bits are stored in the next subsequent bit positions. After reception, RxAlign[2:0] is automatically cleared. For example:
		000	the LSB of the received bit is stored in bit position 0 and the second received bit is stored in bit position 1
		001	the LSB of the received bit is stored in bit position 1, the second received bit is stored in bit position 2
		..	
	111	the LSB of the received bit is stored in bit position 7, the second received bit is stored in the next byte in bit position 0	
3	0	-	reserved
2 to 0	TxLastBits[2:0]	-	defines the number of bits of the last byte that shall be transmitted. 000 indicates that all bits of the last byte will be transmitted. TxLastBits[2:0] is automatically cleared after transmission.



10.5.3 Page 2: Transmitter and control

10.5.3.1 Page register

Selects the page register; see [Section 10.5.1.1 “Page register” on page 50](#).

10.5.3.2 TxControl register

Controls the logical behavior of the antenna pin TX1 and TX2.

Table 71. TxControl register (address: 11h) reset value: 0101 1000b, 58h bit allocation

Bit	7	6	5	4	3	2	1	0
Symbol	0	ModulatorSource [1:0]		Force 100ASK	TX2Inv	TX2Cw	TX2RFEn	TX1RFEn
Access	R/W	R/W		R/W	R/W	R/W	R/W	R/W

Table 72. TxControl register bit descriptions

Bit	Symbol	Value	Description
7	0	-	this value must not be changed
6 to 5	ModulatorSource[1:0]		selects the source for the modulator input:
		00	modulator input is LOW
		01	modulator input is HIGH
		10	modulator input is the internal encoder
	11	modulator input is pin MFIN	
4	Force100ASK	-	forces a 100 % ASK modulation independent ModConductance register setting
3	TX2Inv	0	delivers an inverted 13.56 MHz energy carrier output signal on pin TX2
2	TX2Cw	1	delivers a continuously unmodulated 13.56 MHz energy carrier output signal on pin TX2
		0	enables modulation of the 13.56 MHz energy carrier
1	TX2RFEn	1	the output signal on pin TX2 is the 13.56 MHz energy carrier modulated by the transmission data
		0	TX2 is driven at a constant output level
0	TX1RFEn	1	the output signal on pin TX1 is the 13.56 MHz energy carrier modulated by the transmission data
		0	TX1 is driven at a constant output level



10.5.3.3 CwConductance register

Selects the conductance of the antenna driver pins TX1 and TX2.

Table 73. CwConductance register (address: 12h) reset value: 0011 1111b, 3Fh bit allocation

Bit	7	6	5	4	3	2	1	0
Symbol	00		GsCfgCW[5:0]					
Access	R/W	R/W	R/W					

Table 74. CwConductance register bit descriptions

Bit	Symbol	Description
7 to 6	00	these values must not be changed
5 to 0	GsCfgCW[5:0]	defines the conductance register value for the output driver. This can be used to regulate the output power/current consumption and operating distance.

See [Section 9.9.3 on page 32](#) for detailed information about GsCfgCW[5:0].

10.5.3.4 ModConductance register

Defines the driver output conductance.

Table 75. ModConductance register (address: 13h) reset value: 0011 1111b, 3Fh bit allocation

Bit	7	6	5	4	3	2	1	0
Symbol	00		GsCfgMod[5:0]					
Access	R/W	R/W	R/W					

Table 76. ModConductance register bit descriptions

Bit	Symbol	Description
7 to 6	00	these values must not be changed
5 to 0	GsCfgMod[5:0]	defines the ModConductance register value for the output driver during modulation. This is used to regulate the modulation index.

Remark: When Force100ASK = logic 1, the GsCfgMod[5:0] value has no effect.

See [Section 9.9.3 on page 32](#) for detailed information about GsCfgMod[5:0].



10.5.3.5 CoderControl register

Sets the clock rate and the coding mode.

Table 77. CoderControl register (address: 14h) reset value: 0001 1001b, 19h bit allocation

Bit	7	6	5	4	3	2	1	0
Symbol	SendOnePulse	0	CoderRate[2:0]			TxCoding[2:0]		
Access	R/W	R/W	R/W			R/W		

Table 78. CoderControl register bit descriptions

Bit	Symbol	Value	Description
7	SendOnePulse	1	forced ISO/IEC 15693 modulation. This is used to switch to the next TimeSlot if the Inventory command is used.
		0	this bit is not cleared automatically, it must be reset by the user to logic 0
6	0	-	this value must not be changed
5 to 3	CoderRate[2:0]		this register defines the clock rate for the encoder circuit
		000	MIFARE 848 kBd
		001	MIFARE 424 kBd
		010	MIFARE 212 kBd
		011	MIFARE 106 kBd; ISO/IEC 14443 A
		100	ISO/IEC 14443 B
		101	I-CODE1 standard mode and ISO/IEC 15693 (~52.97 kHz)
		110	I-CODE1 fast mode (~26.48 kHz)
2 to 0	TxCoding[2:0]		this register defines the bit coding mode and framing during transmission
		000	NRZ according to ISO/IEC 14443 B
		001	MIFARE, ISO/IEC 14443 A, (Miller coded)
		010	reserved
		011	reserved
		100	I-CODE1 standard mode (1 out of 256 coding)
		101	I-CODE1 fast mode (NRZ coding)
		110	ISO/IEC 15693 standard mode (1 out of 256 coding)
111	ISO/IEC 15693 fast mode (1 out of 4 coding)		



10.5.3.6 ModWidth register

Selects the pulse-modulation width.

Table 79. ModWidth register (address: 15h) reset value: 0001 0011b, 13h bit allocation

Bit	7	6	5	4	3	2	1	0
Symbol	ModWidth[7:0]							
Access	R/W							

Table 80. ModWidth register bit descriptions

Bit	Symbol	Description
7 to 0	ModWidth[7:0]	defines the width of the modulation pulse based on $t_{mod} = 2 \cdot (\text{ModWidth} + 1) / f_{clk}$

10.5.3.7 ModWidthSOF register

Table 81. ModWidthSOF register (address: 16h) reset value: 0011 1111b, 3Fh bit allocation

Bit	7	6	5	4	3	2	1	0
Symbol	ModWidthSOF[7:0]							
Access	R/W							

Table 82. ModWidthSOF register bit descriptions

Bit	Symbol	Value	Description
7 to 0	ModWidthSOF		defines the width of the modulation pulse for SOF as $t_{mod} = 2 \cdot (\text{ModWidth} + 1) / f_{clk}$ the register settings are:
		3Fh	MIFARE and ISO/IEC 14443; modulation width SOF = 9.44 μ s
		3Fh	I-CODE1 standard mode; modulation width SOF = 9.44 μ s
		73h	I-CODE1 fast mode; modulation width SOF = 18.88 μ s
		3Fh	ISO/IEC 15693; modulation width SOF = 9.44 μ s



10.5.3.8 TypeBFraming

Defines the framing for ISO/IEC 14443 B communication.

Table 83. TypeBFraming register (address: 17h) reset value: 0011 1011b, 3Bh bit allocation

Bit	7	6	5	4	3	2	1	0
Symbol	NoTxSOF	NoTxEOF	EOFWidth	CharSpacing[2:0]		SOFWidth[1:0]		
Access	R/W	R/W	R/W	R/W		R/W		

Table 84. TypeBFraming register bit descriptions

Bit	Symbol	Value	Description
7	NoTxSOF	1	TxCoder suppresses the SOF
		0	TxCoder does not suppress SOF
6	NoTxEOF	1	TxCoder suppresses the EOF
		0	TxCoder does not suppress the EOF
5	EOFWidth	1	set the EOF to a length to 11 ETU
		0	set the EOF to a length of 10 ETU
4 to 2	CharSpacing[2:0]		set the EGT length between 0 and 7 ETU
1 to 0	SOFWidth[1:0]	00	sets the SOF to a length to 10 ETU LOW and 2 ETU HIGH
		01	sets the SOF to a length of 10 ETU LOW and 3 ETU HIGH
		10	sets the SOF to a length of 11 ETU LOW and 2 ETU HIGH
		11	sets the SOF to a length of 11 ETU LOW and 3 ETU HIGH



10.5.4 Page 3: Receiver and decoder control

10.5.4.1 Page register

Selects the page register; see [Section 10.5.1.1 “Page register”](#) on page 50.

10.5.4.2 RxControl1 register

Controls receiver operation.

Table 85. RxControl1 register (address: 19h) reset value: 0111 0011b, 73h bit allocation

Bit	7	6	5	4	3	2	1	0
Symbol	SubCPulses[2:0]			ISOSelection[1:0]		LPOff	Gain[1:0]	
Access	R/W			R/W		R/W	R/W	

Table 86. RxControl1 register bit descriptions

Bit	Symbol	Value	Description
7 to 5	SubCPulses[2:0]		defines the number of subcarrier pulses for each bit
		000	1 pulse for each bit
		001	2 pulses for each bit
		010	4 pulses for each bit
		011	8 pulses for each bit ISO/IEC 14443 A and ISO/IEC 14443 B
		100	16 pulses for each bit I-CODE1, ISO/IEC 15693
		101	reserved
		110	reserved
4 to 3	ISOSelection[1:0]		used to select the communication protocol
		00	reserved
		10	ISO/IEC 14443 A and ISO/IEC 14443 B
		01	I-CODE1, ISO/IEC 15693
		11	reserved
2	LPOff		switches off a low-pass filter at the internal amplifier
1 to 0	Gain[1:0]		defines the receiver's signal voltage gain factor
		00	20 dB gain factor
		01	24 dB gain factor
		10	31 dB gain factor
		11	35 dB gain factor



10.5.4.3 DecoderControl register

Controls decoder operation.

Table 87. DecoderControl register (address: 1Ah) reset value: 0000 1000b, 08h bit allocation

Bit	7	6	5	4	3	2	1	0
Symbol	0	RxMultiple	ZeroAfterColl	RxFraming[1:0]	RxInvert	0	RxCoding	
Access	R/W	R/W	R/W	R/W	R/W	R/W	R/W	R/W

Table 88. DecoderControl register bit descriptions

Bit	Symbol	Value	Description
7	0	-	this value must not be changed
6	RxMultiple	0	after receiving one frame, the receiver is deactivated
		1	enables reception of more than one frame
5	ZeroAfterColl	1	any bits received after a bit-collision are masked to zero. This helps to resolve the anti-collision procedure as defined in ISO/IEC 14443 A
4 to 3	RxFraming[1:0]	00	I-CODE1
		01	MIFARE or ISO/IEC 14443 A
		10	ISO/IEC 15693
		11	ISO/IEC 14443 B
2	RxInvert	0	modulation at the first half-bit results in logic 1 (I-CODE1)
		1	modulation at the first half-bit results in logic 0 (ISO/IEC 15693)
1	0	-	this value must not be changed
0	RxCoding	0	Manchester encoding
		1	BPSK encoding

10.5.4.4 BitPhase register

Selects the bit-phase between transmitter and receiver clock.

Table 89. BitPhase register (address: 1Bh) reset value: 1010 1101b, ADh bit allocation

Bit	7	6	5	4	3	2	1	0
Symbol	BitPhase[7:0]							
Access	R/W							

Table 90. BitPhase register bit descriptions

Bit	Symbol	Description
7 to 0	BitPhase	defines the phase relationship between transmitter and receiver clock Remark: The correct value of this register is essential for proper operation.



10.5.4.5 RxThreshold register

Selects thresholds for the bit decoder.

Table 91. RxThreshold register (address: 1Ch) reset value: 1111 1111b, FFh bit allocation

Bit	7	6	5	4	3	2	1	0
Symbol	MinLevel[3:0]				CollLevel[3:0]			
Access	R/W				R/W			

Table 92. RxThreshold register bit descriptions

Bit	Symbol	Description
7 to 4	MinLevel[3:0]	the minimum signal strength the decoder will accept. If the signal strength is below this level, it is not evaluated.
3 to 0	CollLevel[3:0]	the minimum signal strength the decoder input that must be reached by the weaker half-bit of the Manchester encoded signal to generate a bit-collision (relative to the amplitude of the stronger half-bit)

10.5.4.6 BPSKDemControl

Controls BPSK demodulation.

Table 93. BPSKDemControl register (address: 1Dh) reset value: 0001 1110b, 1Eh bit allocation

Bit	7	6	5	4	3	2	1	0
Symbol	NoRxSOF	NoRxEGT	NoRxEOF	FilterAmpDet	TauD[1:0]		TauB[1:0]	
Access	R/W	R/W	R/W	R/W	R/W		R/W	

Table 94. BPSKDemControl register bit descriptions

Bit	Symbol	Value	Description
7	NoRxSOF	1	a missing SOF in the received data stream is ignored and no framing errors are indicated
		0	a missing SOF in the received data stream generates framing errors
6	NoRxEGT	1	an EGT which is too short or too long in the received data stream is ignored and no framing errors are indicated
		0	an EGT which is too short or too long in the received data stream will cause framing errors
5	NoRxEOF	1	a missing EOF in the received data stream is ignored and no framing errors indicated
		0	a missing EOF in the receiving data stream produces framing errors
4	FilterAmpDet	-	switches on a high-pass filter for amplitude detection
3 to 2	TauD[1:0]	-	changes the time constant of the internal PLL whilst receiving data
1 to 0	TauB[1:0]	-	changes the time constant of the internal PLL during data bursts



10.5.4.7 RxControl2 register

Controls decoder behavior and defines the input source for the receiver.

Table 95. RxControl2 register (address: 1Eh) reset value: 0100 0001b, 41h bit allocation

Bit	7	6	5	4	3	2	1	0
Symbol	RcvClkSell	RxAutoPD	0000			DecoderSource[1:0]		
Access	R/W	R/W	R/W			R/W		

Table 96. RxControl2 register bit descriptions

Bit	Symbol	Value	Description
7	RcvClkSell	1	I-clock is used as the receiver clock ^[1]
		0	Q-clock is used as the receiver clock ^[1]
6	RxAutoPD	1	receiver circuit is automatically switched on before receiving and switched off afterwards. This can be used to reduce current consumption.
		0	receiver is always activated
5 to 2	0000	-	these values must not be changed
1 to 0	DecoderSource[1:0]	-	selects the source for the decoder input
		00	LOW
		01	internal demodulator
		10	a subcarrier modulated Manchester encoded signal on pin MFIN
		11	a baseband Manchester encoded signal on pin MFIN

[1] I-clock and Q-clock are 90° phase-shifted from each other.

10.5.4.8 ClockQControl register

Controls clock generation for the 90° phase-shifted Q-clock.

Table 97. ClockQControl register (address: 1Fh) reset value: 000x xxxxb, xxh bit allocation

Bit	7	6	5	4	3	2	1	0
Symbol	ClkQ180Deg	ClkQCalib	0	ClkQDelay[4:0]				
Access	R	R/W	R/W	D				

Table 98. ClockQControl register bit descriptions

Bit	Symbol	Value	Description
7	ClkQ180Deg	1	Q-clock is phase-shifted more than 180° compared to the I-clock
		0	Q-clock is phase-shifted less than 180° compared to the I-clock
6	ClkQCalib	0	Q-clock is automatically calibrated after the reset phase and after data reception from the card
		1	no calibration is performed automatically
5	0	-	this value must not be changed
4 to 0	ClkQDelay[4:0]	-	this register shows the number of delay elements used to generate a 90° phase-shift of the I-clock to obtain the Q-clock. It can be written directly by the microprocessor or by the automatic calibration cycle.



10.5.5 Page 4: RF Timing and channel redundancy

10.5.5.1 Page register

Selects the page register; see [Section 10.5.1.1 “Page register” on page 50](#).

10.5.5.2 RxWait register

Selects the time interval after transmission, before the receiver starts.

Table 99. RxWait register (address: 21h) reset value: 0000 0101b, 06h bit allocation

Bit	7	6	5	4	3	2	1	0
Symbol	RxWait[7:0]							
Access	R/W							

Table 100. RxWait register bit descriptions

Bit	Symbol	Function
7 to 0	RxWait[7:0]	after data transmission, the activation of the receiver is delayed for RxWait bit-clock cycles. During this frame guard time any signal on pin RX is ignored.

10.5.5.3 ChannelRedundancy register

Selects kind and mode of checking the data integrity on the RF channel.

Table 101. ChannelRedundancy register (address: 22h) reset value: 0000 0011b, 03h bit allocation

Bit	7	6	5	4	3	2	1	0
Symbol	00		CRC3309	CRC8	RxCRCEn	TxCRCEn	ParityOdd	ParityEn
Access	R/W	R/W	R/W	R/W	R/W	R/W	R/W	R/W

Table 102. ChannelRedundancy bit descriptions

Bit	Symbol	Value	Function
7 to 6	00	-	this value must not be changed
5	CRC3309	1	CRC calculation is performed using ISO/IEC 3309 (ISO/IEC 14443 B) and ISO/IEC 15693
		0	CRC calculation is performed using ISO/IEC 14443 A and I-CODE1
4	CRC8	1	an 8-bit CRC is calculated
		0	a 16-bit CRC is calculated
3	RxCRCEn	1	the last byte(s) of a received frame are interpreted as CRC bytes. If the CRC is correct, the CRC bytes are not passed to the FIFO. If the CRC bytes are incorrect, the CRCerr flag is set.
		0	no CRC is expected
2	TxCRCEn	1	a CRC is calculated over the transmitted data and the CRC bytes are appended to the data stream
		0	no CRC is transmitted



Table 102. ChannelRedundancy bit descriptions

Bit	Symbol	Value	Function
1	ParityOdd	1	odd parity is generated or expected ^[1]
		0	even parity is generated or expected
0	ParityEn	1	a parity bit is inserted in the transmitted data stream after each byte and expected in the received data stream after each byte (MIFARE, ISO/IEC 14443 A)
		0	no parity bit is inserted or expected (ISO/IEC 14443 B)

[1] When used with ISO/IEC 14443 A, this bit must be set to logic 1.

10.5.5.4 CRCPresetLSB register

LSB of the preset value for the CRC register.

Table 103. CRCPresetLSB register (address: 23h) reset value: 0101 0011b, 63h bit allocation

Bit	7	6	5	4	3	2	1	0
Symbol	CRCPresetLSB[7:0]							
Access	R/W							

Table 104. CRCPresetLSB register bit descriptions

Bit	Symbol	Description
7 to 0	CRCPresetLSB[7:0]	defines the start value for CRC calculation. This value is loaded into the CRC at the beginning of transmission, reception and the CalcCRC command (if CRC calculation is enabled) ^[1] .

[1] To use the ISO/IEC 15693 functionality, the CRCPresetLSB register has to be set to FFh.

10.5.5.5 CRCPresetMSB register

MSB of the preset value for the CRC register.

Table 105. CRCPresetMSB register (address: 24h) reset value: 0101 0011b, 63h bit allocation

Bit	7	6	5	4	3	2	1	0
Symbol	CRCPresetMSB[7:0]							
Access	R/W							

Table 106. CRCPresetMSB bit descriptions

Bit	Symbol	Description
7 to 0	CRCPresetMSB[7:0]	defines the starting value for CRC calculation. This value is loaded into the CRC at the beginning of transmission, reception and the CalcCRC command (if the CRC calculation is enabled) Remark: This register is not relevant if CRC8 is set to logic 1.

10.5.5.6 TimeSlotPeriod register

Defines the time-slot period for I-CODE1 protocol.

Table 107. TimeSlotPeriod register (address: 25h) reset value: 0000 0000b, 00h bit allocation

Bit	7	6	5	4	3	2	1	0
Symbol	TimeSlotPeriod[7:0]							
Access	R/W							



Table 108. TimeSlotPeriod register bit descriptions

Bit	Symbol	Description
7 to 0	TimeSlotPeriod[7:0]	defines the time between automatically transmitted frames. To send a Quit frame using the I-CODE1 protocol it is necessary to relate to the beginning of the command frame. The TimeSlotPeriod starts at the end of the command transmission. See Section 9.5.1.5 on page 26 for additional information.

10.5.5.7 MFOUTSelect register

Selects the internal signal applied to pin MFOUT.

Table 109. MFOUTSelect register (address: 26h) reset value: 0000 0000b, 00h bit allocation

Bit	7	6	5	4	3	2	1	0
Symbol	000			TimeSlotPeriodMSB	0	MFOUTSelect[2:0]		
Access	R/W	R/W	R/W	R/W	R/W	R/W		

Table 110. MFOUTSelect register bit descriptions

Bit	Symbol	Value	Description
7 to 5	000	-	these values must not be changed
4	TimeSlotPeriodMSB	-	MSB of value TimeSlotPeriod; see Table 107 on page 69 for more detailed information
3	0	-	this value must not be changed
2 to 0	MFOUTSelect[2:0]		defines which signal is routed to pin MFOUT:
		000	constant LOW
		001	constant HIGH
		010	modulation signal (envelope) from the internal encoder, (Miller coded)
		011	serial data stream, not Miller encoded
		100	output signal of the energy carrier demodulator (card modulation signal) ^[1]
		101	output signal of the subcarrier demodulator (Manchester encoded card signal) ^[1]
		110	reserved
111	reserved		

[1] Only valid for MIFARE and ISO/IEC 14443 A communication at 106 kBd.

10.5.5.8 PreSet27 register

Table 111. PreSet27 (address: 27h) reset value: xxxx xxxxb, xxh bit allocation

Bit	7	6	5	4	3	2	1	0
Symbol	x	x	x	x	x	x	x	x
Access	W	W	W	W	W	W	W	W

**10.5.6 Page 5: FIFO, timer and IRQ pin configuration****10.5.6.1 Page register**

Selects the page register; see [Section 10.5.1.1 “Page register”](#) on page 50.

10.5.6.2 FIFOLevel register

Defines the levels for FIFO underflow and overflow warning.

Table 112. FIFOLevel register (address: 29h) reset value: 0000 1000b, 08h bit allocation

Bit	7	6	5	4	3	2	1	0
Symbol	00		WaterLevel[5:0]					
Access	R/W	R/W	R/W					

Table 113. FIFOLevel register bit descriptions

Bit	Symbol	Description
7 to 6	00	these values must not be changed
5 to 0	WaterLevel[5:0]	defines, the warning level of a FIFO buffer overflow or underflow: HiAlert is set to logic 1 if the remaining FIFO buffer space is equal to, or less than, WaterLevel[5:0] bits in the FIFO buffer. LoAlert is set to logic 1 if equal to, or less than, WaterLevel[5:0] bits in the FIFO buffer.

10.5.6.3 TimerClock register

Selects the divider for the timer clock.

Table 114. TimerClock register (address: 2Ah) reset value: 0000 0111b, 07h bit allocation

Bit	7	6	5	4	3	2	1	0
Symbol	00		TAutoRestart	TPreScaler[4:0]				
Access	R/W	R/W	R/W	R/W				

Table 115. TimerClock register bit descriptions

Bit	Symbol	Value	Function
7 to 6	00	-	these values must not be changed
5	TAutoRestart	1	the timer automatically restarts its countdown from the TReloadValue[7:0] instead of counting down to zero
		0	the timer decrements to zero and register InterruptIrq TimerIRq bit is set to logic 1
4 to 0	TPreScaler[4:0]	-	defines the timer clock frequency ($f_{\text{TimerClock}}$). The TPreScaler[4:0] can be adjusted from 0 to 21. The following formula is used to calculate the TimerClock frequency ($f_{\text{TimerClock}}$): $f_{\text{TimerClock}} = 13.56 \text{ MHz} / 2^{\text{TPreScaler}} \text{ [MHz]}$



10.5.6.4 TimerControl register

Selects start and stop conditions for the timer.

Table 116. TimerControl register (address: 2Bh) reset value: 0000 0110b, 06h bit allocation

Bit	7	6	5	4	3	2	1	0
Symbol	0000			TStopRxEnd	TStopRxBegin	TStartTxEnd	TStartTxBegin	
Access	R/W			R/W	R/W	R/W	R/W	R/W

Table 117. TimerControl register bit descriptions

Bit	Symbol	Value	Description
7 to 4	0000	-	these values must not be changed
3	TStopRxEnd	1	the timer automatically stops when data reception ends
		0	the timer is not influenced by this condition
2	TStopRxBegin	1	the timer automatically stops when the first valid bit is received
		0	the timer is not influenced by this condition
1	TStartTxEnd	1	the timer automatically starts when data transmission ends. If the timer is already running, the timer restarts by loading TReloadValue[7:0] into the timer.
		0	the timer is not influenced by this condition
0	TStartTxBegin	1	the timer automatically starts when the first bit is transmitted. If the timer is already running, the timer restarts by loading TReloadValue[7:0] into the timer.
		0	the timer is not influenced by this condition

10.5.6.5 TimerReload register

Defines the preset value for the timer.

Table 118. TimerReload register (address: 2Ch) reset value: 0000 1010b, 0Ah bit allocation

Bit	7	6	5	4	3	2	1	0
Symbol	TReloadValue[7:0]							
Access	R/W							

Table 119. TimerReload register bit descriptions

Bit	Symbol	Description
7 to 0	TReloadValue[7:0]	on a start event, the timer loads the TReloadValue[7:0] value. Changing this register only affects the timer on the next start event. If TReloadValue[7:0] is set to logic 0 the timer cannot start.



10.5.6.6 IRQPinConfig register

Configures the output stage for pin IRQ.

Table 120. IRQPinConfig register (address: 2Dh) reset value: 0000 0010b, 02h bit allocation

Bit	7	6	5	4	3	2	1	0
Symbol	000000						IRQInv	IRQPushPull
Access	R/W						R/W	R/W

Table 121. IRQPinConfig register bit descriptions

Bit	Symbol	Value	Description
7 to 2	000000	-	these values must not be changed
1	IRQInv	1	inverts the signal on pin IRQ with respect to bit IRq
		0	the signal on pin IRQ is not inverted and is the same as bit IRq
0	IRQPushPull	1	pin IRQ functions as a standard CMOS output pad
		0	pin IRQ functions as an open-drain output pad

10.5.6.7 PreSet2E register

Table 122. PreSet2E register (address: 2Eh) reset value: xxxx xxxxb, xxh bit allocation

Bit	7	6	5	4	3	2	1	0
Symbol	x	x	x	x	x	x	x	x
Access	W	W	W	W	W	W	W	W

10.5.6.8 PreSet2F register

Table 123. PreSet2F register (address: 2Fh) reset value: xxxx xxxxb, xxh bit allocation

Bit	7	6	5	4	3	2	1	0
Symbol	x	x	x	x	x	x	x	x
Access	W	W	W	W	W	W	W	W

10.5.7 Page 6: reserved

10.5.7.1 Page register

Selects the page register; see [Section 10.5.1.1 “Page register”](#) on page 50.

10.5.7.2 Reserved registers 31h, 32h, 33h, 34h, 35h, 36h and 37h

Table 124. Reserved registers (address: 31h, 32h, 33h, 34h, 35h, 36h, 37h) reset value: xxxx xxxxb, xxh bit allocation

Bit	7	6	5	4	3	2	1	0
Symbol	x	x	x	x	x	x	x	x
Access	R/W	R/W	R/W	R/W	R/W	R/W	R/W	R/W

Remark: These registers are reserved for future use.



10.5.8 Page 7: Test control

10.5.8.1 Page register

Selects the page register; see [Section 10.5.1.1 “Page register”](#) on page 50.

10.5.8.2 Reserved register 39h

Table 125. Reserved register (address: 39h) reset value: xxxx xxxxb, xxh bit allocation

Bit	7	6	5	4	3	2	1	0
Symbol	x	x	x	x	x	x	x	x
Access	W	W	W	W	W	W	W	W

Remark: This register is reserved for future use.

10.5.8.3 TestAnaSelect register

Selects analog test signals.

Table 126. TestAnaSelect register (address: 3Ah) reset value: 0000 0000b, 00h bit allocation

Bit	7	6	5	4	3	2	1	0
Symbol	0000				TestAnaOutSel[4:0]			
Access	W				W			

Table 125. TestAnaSelect bit descriptions

Bit	Symbol	Value	Description
7 to 4	0000	-	these values must not be changed
3 to 0	TestAnaOutSel[4:0]		selects the internal analog signal to be routed to pin AUX. See Section 15.2.2 on page 112 for detailed information. The settings are as follows:
		0	VMID
		1	Vbandgap
		2	VRxFollI
		3	VRxFollQ
		4	VRxAmpI
		5	VRxAmpQ
		6	VCorrNI
		7	VCorrNQ
		8	VCorrDI
		9	VCorrDQ
		A	VEvalL
		B	VEvalR
		C	VTemp
D	reserved		
E	reserved		
F	reserved		



10.5.8.4 Reserved register 3Bh

Table 128. Reserved register (address: 3Bh) reset value: xxxx xxxxb, xxh bit allocation

Bit	7	6	5	4	3	2	1	0
Symbol	x	x	x	x	x	x	x	x
Access	W	W	W	W	W	W	W	W

Remark: This register is reserved for future use.

10.5.8.5 Reserved register 3Ch

Table 129. Reserved register (address: 3Ch) reset value: xxxx xxxxb, xxh bit allocation

Bit	7	6	5	4	3	2	1	0
Symbol	x	x	x	x	x	x	x	x
Access	W	W	W	W	W	W	W	W

Remark: This register is reserved for future use.

10.5.8.6 TestDigiSelect register

Selects digital test mode.

Table 130. TestDigiSelect register (address: 3Dh) reset value: xxxx xxxxb, xxh bit allocation

Bit	7	6	5	4	3	2	1	0
Symbol	SignalToMFOUT	TestDigiSignalSel[6:0]						
Access	W	W						

Table 131. TestDigiSelect register bit descriptions

Bit	Symbol	Value	Description
7	SignalToMFOUT	1	overrides the MFOUTSelect[2:0] setting and routes the digital test signal defined with the TestDigiSignalSel[6:0] bits to pin MFOUT
		0	MFOUTSelect[2:0] defines the signal on pin MFOUT
6 to 0	TestDigiSignalSel[6:0]	-	selects the digital test signal to be routed to pin MFOUT. Refer to Section 15.2.3 on page 113 for detailed information. The following lists the signal names for the TestDigiSignalSel[6:0] addresses:
		F4h	s_data
		E4h	s_valid
		D4h	s_coll
		C4h	s_clock
		B5h	rd_sync
		A5h	wr_sync
		96h	int_clock
83h	BPSK_out		
E2h	BPSK_sig		



10.5.8.7 Reserved registers 3Eh, 3Fh

Table 132. Reserved register (address: 3Eh, 3Fh) reset value: xxxx xxxxb, xxh bit allocation

Bit	7	6	5	4	3	2	1	0
Symbol	x	x	x	x	x	x	x	x
Access	W	W	W	W	W	W	W	W

Remark: This register is reserved for future use.

11. FSV9532 command set

FSV9532 operation is determined by an internal state machine capable of performing a command set. The commands can be started by writing the command code to the Command register. Arguments and/or data necessary to process a command are mainly exchanged using the FIFO buffer.

- Each command needing a data stream (or data byte stream) as an input immediately processes the data in the FIFO buffer
- Each command that requires arguments only starts processing when it has received the correct number of arguments from the FIFO buffer
- The FIFO buffer is not automatically cleared at the start of a command. It is, therefore, possible to write command arguments and/or the data bytes into the FIFO buffer before starting a command.
- Each command (except the StartUp command) can be interrupted by the microprocessor writing a new command code to the Command register e.g. the Idle command.

11.1 FSV9532 command overview

Table 133. FSV9532 commands overview

Command	Value	Action	FIFO communication	
			Arguments and data sent	Data received
StartUp	3Fh	runs the reset and initialization phase. See Section 11.1.2 on page 78 . Remark: This command can only be activated by Power-On or Hard resets.	-	-
Idle	00h	no action; cancels execution of the current command. See Section 11.1.3 on page 78	-	-
Transmit	1Ah	transmits data from the FIFO buffer to the card. See Section 11.2.1 on page 79	data stream	-
Receive	16h	activates receiver circuitry. Before the receiver starts, the state machine waits until the time defined in the RxWait register has elapsed. See Section 11.2.2 on page 82 . Remark: This command may be used for test purposes only, since there is no timing relationship to the Transmit command.	-	data stream



Table 133. FSV9532 commands overview

Command	Value	Action	FIFO communication	
			Arguments and data sent	Data received
Transceiver ^[1]	1Eh	transmits data from FIFO buffer to the card and automatically activates the receiver after transmission. The receiver waits until the time defined in the RxWait register has elapsed before starting. See Section 11.2.3 on page 85 .	data stream	data stream
WriteE2	01h	reads data from the FIFO buffer and writes it to the EEPROM. See Section 11.4.1 on page 93 .	start address LSB start address MSB data byte stream	-
ReadE2	03h	reads data from the EEPROM and sends it to the FIFO buffer. See Section 11.4.2 on page 95 . Remark: Keys cannot be read back	start address LSB start address MSB number of data bytes	data bytes
LoadKeyE2	0Bh	copies a key from the EEPROM into the key buffer ^[2] . See Section 11.7.1 on page 97 .	start address LSB start address MSB	-
LoadKey	19h	reads a key from the FIFO buffer and loads it into the key buffer ^[2] . See Section 11.7.2 on page 97 . Remark: The key has to be prepared in a specific format (refer to Section 9.2.3.1 "Key format" on page 18)	byte 0 LSB byte 1 ... byte 10 byte 11 MSB	-
Authent1	0Ch	performs the first part of card authentication using the Crypto1 algorithm ^[2] . See Section 11.7.3 on page 98 .	card Authent1 command card block address card serial number LSB card serial number byte 1 card serial number byte 2 card serial number MSB	-
Authent2	14h	performs the second part of card authentication using the Crypto1 algorithm ^[2] . See Section 11.7.4 on page 98 .	-	-
LoadConfig	07h	reads data from EEPROM and initializes the FSV9532 registers. See Section 11.5.1 on page 95 .	start address LSB start address MSB	-
CalcCRC	12h	activates the CRC coprocessor Remark: The result of the CRC calculation is read from the CRCResultLSB and CRCResultMSB registers. See Section 11.5.2 on page 96 .	data byte stream	-

[1] This command is the combination of the Transmit and Receive commands.

[2] Relates to MIFARE Mini/MIFARE 1K/MIFARE 4K security.



11.1.1 Basic states

11.1.2 StartUp command 3Fh

Table 134. StartUp command 3Fh

Command	Value	Action	Arguments and data	Returned data
StartUp	3Fh	runs the reset and initialization phase	-	-

Remark: This command can only be activated by a Power-On or Hard reset.

The StartUp command runs the reset and initialization phases. It does not need or return, any data. It cannot be activated by the microprocessor but is automatically started after one of the following events:

- Power-On Reset (POR) caused by power-up on pin DVDD
- POR caused by power-up on pin AVDD
- Negative edge on pin RSTPD

The reset phase comprises an asynchronous reset and configuration of certain register bits. The initialization phase configures several registers with values stored in the EEPROM.

When the StartUp command finishes, the Idle command is automatically executed.

Remark:

- The microprocessor must not write to the FSV9532 while it is still executing the StartUp command. To avoid this, the microprocessor polls for the Idle command to determine when the initialization phase has finished; see [Section 9.7.4 on page 30](#).
- When the StartUp command is active, it is only possible to read from the Page 0 register.
- The StartUp command cannot be interrupted by the microprocessor.

11.1.3 Idle command 00h

Table 135. Idle command 00h

Command	Value	Action	Arguments and data	Returned data
Idle	00h	no action; cancels current command execution	-	-

The Idle command switches the FSV9532 to its inactive state where it waits for the next command. It does not need or return, any data.

The device automatically enters the idle state when a command finishes. When this happens, the FSV9532 sends an interrupt request by setting bit IdleIRq. When triggered by the microprocessor, the Idle command can be used to stop execution of all other commands (except the StartUp command) but this does not generate an interrupt request (IdleIRq).

Remark: Stopping command execution with the Idle command does not clear the FIFO buffer.



11.2 Commands for ISO/IEC 14443 A card communication

The FSV9532 is a fully ISO/IEC 14443 A, ISO/IEC 14443 B, ISO/IEC 15693 and I-CODE1 compliant reader IC. This enables the command set to be more flexible and generalized when compared to dedicated MIFARE or I-CODE1 reader ICs. [Section 11.2.1](#) to [Section 11.2.5](#) describe the command set for ISO/IEC 14443 A card communication and related communication protocols.

11.2.1 Transmit command 1Ah

Table 136. Transmit command 1Ah

Command	Value	Action	Arguments and data	Returned data
Transmit	1Ah	transmits data from FIFO buffer to card	data stream	-

The Transmit command reads data from the FIFO buffer and sends it to the transmitter. It does not return any data. The Transmit command can only be started by the microprocessor.

11.2.1.1 Using the Transmit command

To transmit data, one of the following sequences can be used:

1. All data to be transmitted to the card is written to the FIFO buffer while the Idle command is active. Then the command code for the Transmit command is written to the Command register.
Remark: This is possible for transmission of a data stream up to 64 bytes.
2. The command code for the Transmit command is stored in the Command register. Since there is not any data available in the FIFO buffer, the command is only enabled but transmission is not activated. Data transmission starts when the first data byte is written to the FIFO buffer. To generate a continuous data stream on the RF interface, the microprocessor must write the subsequent data bytes into the FIFO buffer in time.
Remark: This allows transmission of any data stream length but it requires data to be written to the FIFO buffer in time.
3. Part of the data transmitted to the card is written to the FIFO buffer while the Idle command is active. Then the command code for the Transmit command is written to the Command register. While the Transmit command is active, the microprocessor can send further data to the FIFO buffer. This is then appended by the transmitter to the transmitted data stream.
Remark: This allows transmission of any data stream length but it requires data to be written to the FIFO buffer in time.

When the transmitter requests the next data byte to ensure the data stream on the RF interface is continuous and the FIFO buffer is empty, the Transmit command automatically terminates. This causes the internal state machine to change its state from transmit to idle.

When the data transmission to the card is finished, the TxIRq flag is set by the FSV9532 to indicate to the microprocessor transmission is complete.

Remark: If the microprocessor overwrites the transmit code in the Command register with another command, transmission stops immediately on the next clock cycle. This can produce output signals that are not in accordance with ISO/IEC 14443 A.



11.2.1.2 RF channel redundancy and framing

Each ISO/IEC 14443 A transmitted frame consists of a Start Of Frame (SOF) pattern, followed by the data stream and is closed by an End Of Frame (EOF) pattern. These different phases of the transmission sequence can be monitored using the PrimaryStatus register ModemState[2:0] bit; see [Section 11.2.4 on page 85](#).

Depending on the setting of the ChannelRedundancy register bit TxCRCEn, the CRC is calculated and appended to the data stream. The CRC is calculated according to the settings in the ChannelRedundancy register. Parity generation is handled according to the ChannelRedundancy register ParityEn and ParityOdd bits settings.

11.2.1.3 Transmission of bit oriented frames

The transmitter can be configured to send an incomplete last byte. To achieve this the BitFraming register's TxLastBits[2:0] bits must be set at above zero (for example, 1). This is shown in [Figure 16](#).

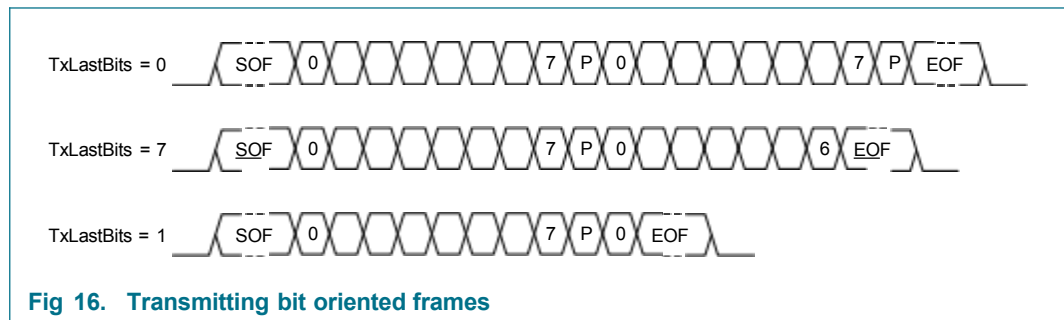

[Figure 16](#) shows the data stream if bit ParityEn is set in the ChannelRedundancy register. All fully transmitted bytes are followed by a parity check bit but the incomplete byte is not followed by a parity check bit. After transmission, the TxLastBits[2:0] bits are automatically cleared.

Remark: If the TxLastBits[2:0] bits are not equal to zero, CRC generation must be disabled. This is done by clearing the ChannelRedundancy register TxCRCEn bit.

11.2.1.4 Transmission of frames with more than 64 bytes

To generate frames of more than 64 bytes, the microprocessor must write data to the FIFO buffer while the Transmit command is active. The state machine checks the FIFO buffer status when it starts transmitting the last bit of the data stream; the check time is marked in [Figure 17](#) with arrows.

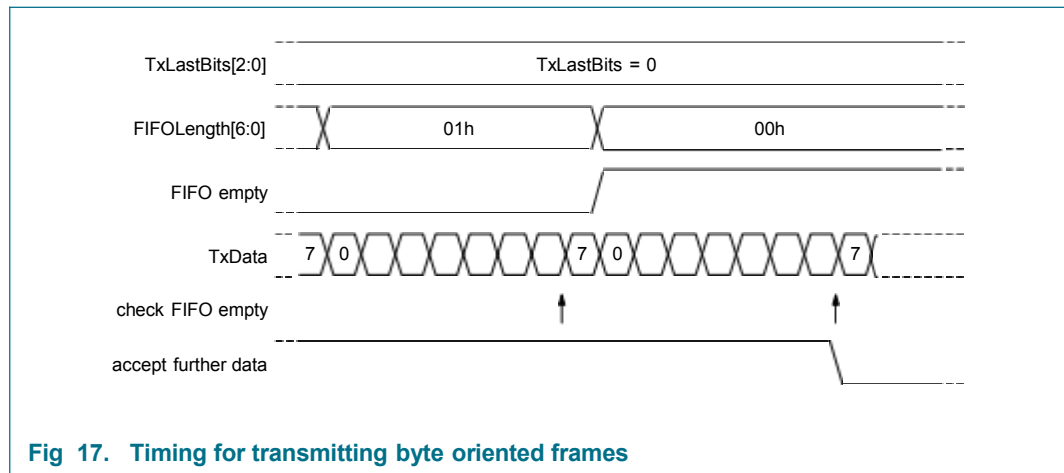

Fig 17. Timing for transmitting byte oriented frames

As long as the internal accept further data signal is logic 1, further data can be written to the FIFO buffer. The FSV9532 appends this data to the data stream transmitted using the RF interface.

If the internal accept further data signal is logic 0, the transmission terminates. All data written to the FIFO buffer after accept further data signal was set to logic 0 is not transmitted, however, it remains in the FIFO buffer.

Remark: If parity generation is enabled (ParityEn = logic 1), the parity bit is the last bit transmitted. This delays the accept further data signal by a duration of one bit.

If the TxLastBits[2:0] bits are not zero, the last byte is not transmitted completely. Only the number of bits set by TxLastBits[2:0], starting with the least significant bit are transmitted. This means that the internal state machine has to check the FIFO buffer status at an earlier point in time; see [Figure 18](#).

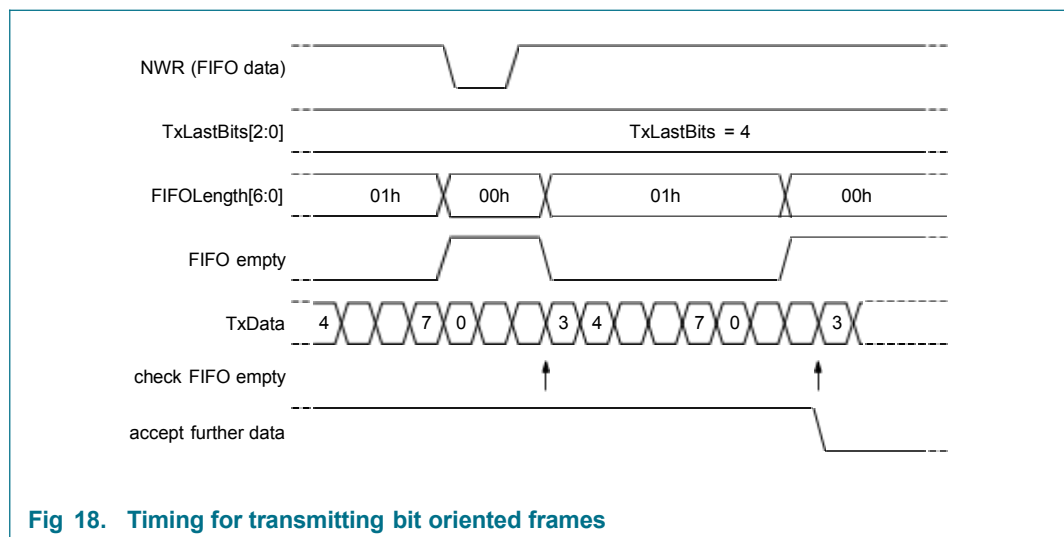

Fig 18. Timing for transmitting bit oriented frames

Since in this example TxLastBits[2:0] = 4, transmission stops after bit 3 is transmitted and the frame is completed with an EOF, if configured.



Figure 18 also shows write access to the FIFOData register just before the FIFO buffer's status is checked. This leads to FIFO empty state being held LOW which keeps the accept further data active. The new byte written to the FIFO buffer is transmitted using the RF interface.

Accept further data is only changed by the check FIFO empty function. This function verifies FIFO empty for one bit duration before the last expected bit transmission.

Table 137. Transmission of frames of more than 64 bytes

Frame definition	Verification at:
8-bit with parity	8 th bit
8-bit without parity	7 th bit
x-bit without parity	(x - 1) th bit

11.2.2 Receive command 16h

Table 138. Receive command 16h

Command	Value	Action	Arguments and data	Returned data
Receive	16h	activates receiver circuitry	-	data stream

The Receive command activates the receiver circuitry. All data received from the RF interface is written to the FIFO buffer. The Receive command can be started either using the microprocessor or automatically during execution of the Transceive command.

Remark: This command can only be used for test purposes since there is no timing relationship to the Transmit command.

11.2.2.1 Using the Receive command

After starting the Receive command, the internal state machine decrements to the RxWait register value on every bit-clock. The analog receiver circuitry is prepared and activated from 3 down to 1. When the counter reaches 0, the receiver starts monitoring the incoming signal at the RF interface.

When the signal strength reaches a level higher than the RxThreshold register MinLevel[3:0] bits value, it starts decoding. The decoder stops when the signal can no longer be detected on the receiver input pin RX. The decoder sets bit RxIRq indicating receive termination.

The different phases of the receive sequence are monitored using the PrimaryStatus register ModemState[2:0] bits; see [Section 11.2.4 on page 85](#).

Remark: Since the counter values from 3 to 0 are needed to initialize the analog receiver circuitry, the minimum value for RxWait[7:0] is 3.

11.2.2.2 RF channel redundancy and framing

The decoder expects the SOF pattern at the beginning of each data stream. When the SOF is detected, it activates the serial-to-parallel converter and gathers the incoming data bits. Every completed byte is forwarded to the FIFO buffer.



If an EOF pattern is detected or the signal strength falls below the RxThreshold register MinLevel[3:0] bits setting, both the receiver and the decoder stop. Then the Idle command is entered and an appropriate response for the microprocessor is generated (interrupt request activated, status flags set).

When the ChannelRedundancy register bit RxCRCEn is set, a CRC block is expected. The CRC block can be one byte or two bytes depending on the ChannelRedundancy register CRC8 bit setting.

Remark: If the CRC block received is correct, it is not sent to the FIFO buffer. This is realized by shifting the incoming data bytes through an internal buffer of either one or two bytes (depending on the defined CRC). The CRC block remains in this internal buffer. Consequently, all data bytes in the FIFO buffer are delayed by one or two bytes. If the CRC fails, all received bytes are sent to the FIFO buffer including the faulty CRC.

If ParityEn is set in the ChannelRedundancy register, a parity bit is expected after each byte. If ParityOdd = logic 1, the expected parity is odd, otherwise even parity is expected.

11.2.2.3 Collision detection

If more than one card is within the RF field during the card selection phase, they both respond simultaneously. The FSV9532 supports the algorithm defined in ISO/IEC 14443 A to resolve card serial number data collisions by performing the anti-collision procedure. The basis for this procedure is the ability to detect bit-collisions.

Bit-collision detection is supported by the Manchester coding bit encoding scheme used in the FSV9532. If in the first and second half-bit of a subcarrier, modulation is detected, instead of forwarding a 1-bit or 0-bit, a bit-collision is indicated. The FSV9532 uses the RxThreshold register CollLevel[3:0] bits setting to distinguish between a 1-bit or 0-bit and a bit-collision. If the amplitude of the half-bit with smaller amplitude is larger than that defined by the CollLevel[3:0] bits, the FSV9532 flags a bit-collision using the error flag CollErr. If a bit-collision is detected in a parity bit, the ParityErr flag is set.

On a detected collision, the receiver continues receiving the incoming data stream. In the case of a bit-collision, the decoder sends logic 1 at the collision position.

Remark: As an exception, if bit ZeroAfterColl is set, all bits received after the first bit-collision are forced to zero, regardless whether a bit-collision or an unequivocal state has been detected. This feature makes it easier for the control software to perform the anti-collision procedure as defined in ISO/IEC 14443 A.

When the first bit collision in a frame is detected, the bit-collision position is stored in the CollPos register.

Table 139 shows the collision positions.



Table 139. Return values for bit-collision positions

Collision in bit	CollPos register value (Decimal)
SOF	0
Least Significant Bit (LSB) of the Least Significant Byte (LSByte)	1
...	...
Most Significant Bit (MSB) of the LSByte	8
LSB of second byte	9
...	...
MSB of second byte	16
LSB of third byte	17
...	...

Parity bits are not counted in the CollPos register because bit-collisions in parity bit occur after bit-collisions in the data bits. If a collision is detected in the SOF, a frame error is flagged and no data is sent to the FIFO buffer. In this case, the receiver continues to monitor the incoming signal. It generates the correct notifications to the microprocessor when the end of the faulty input stream is detected. This helps the microprocessor to determine when it is next allowed to send data to the card.

11.2.2.4 Receiving bit oriented frames

The receiver can manage byte streams with incomplete bytes which result in bit-oriented frames. To support this, the following values may be used:

- BitFraming register's RxAlign[2:0] bits select a bit offset for the first incoming byte. For example, if RxAlign[2:0] = 3, the first 5 bits received are forwarded to the FIFO buffer. Further bits are packed into bytes and forwarded. After reception, RxAlign[2:0] is automatically cleared. If RxAlign[2:0] = logic 0, all incoming bits are packed into one byte.
- RxLastBits[2:0] returns the number of bits valid in the last received byte. For example, if RxLastBits[2:0] evaluates to 5 bits at the end of the received command, the 5 least significant bits are valid. If the last byte is complete, RxLastBits[2:0] evaluates to zero.

RxLastBits[2:0] is only valid if a frame error is not indicated by the FramingErr flag. If RxAlign[2:0] is not zero and ParityEn is active, the first parity bit is ignored and not checked.

11.2.2.5 Communication errors

The events which can set error flags are shown in [Table 140](#).

Table 140. Communication error table

Cause	Flag bit
Received data did not start with the SOF pattern	FramingErr
CRC block is not equal to the expected value	CRCErr
Received data is shorter than the CRC block	CRCErr
The parity bit is not equal to the expected value (i.e. a bit-collision, not parity)	ParityErr
A bit-collision is detected	CollErr



11.2.3 Transceive command 1Eh

Table 141. Transceive command 1Eh

Command	Value	Action	Arguments and data	Returned data
Transceive	1Eh	transmits data from FIFO buffer to the card and then automatically activates the receiver	data stream	data stream

The Transceive command first executes the Transmit command (see [Section 11.2.1 on page 79](#)) and then starts the Receive command (see [Section 11.2.2 on page 82](#)). All data transmitted is sent using the FIFO buffer and all data received is written to the FIFO buffer. The Transceive command can only be started by the microprocessor.

Remark: To adjust the timing relationship between transmitting and receiving, use the RxWait register. This register is used to define the time delay between the last bit transmitted and activation of the receiver. In addition, the BitPhase register determines the phase-shift between the transmitter and receiver clock.

11.2.4 States of the card communication

The status of the transmitter and receiver state machine can be read from bits ModemState[2:0] in the PrimaryStatus register.

The assignment of ModemState[2:0] to the internal action is shown in [Table 142](#).

Table 142. Meaning of ModemState

ModemState [2:0]	State	Description
000	Idle	transmitter and/or receiver are not operating
001	TxSOF	transmitting the SOF pattern
010	TxData	transmitting data from the FIFO buffer (or redundancy CRC check bits)
011	TxEof	transmitting the EOF pattern
100	GoToRx1	intermediate state passed, when receiver starts
	GoToRx2	intermediate state passed, when receiver finishes
101	PrepareRx	waiting until the RxWait register time period expires
110	AwaitingRx	receiver activated; waiting for an input signal on pin RX



11.2.5 Card communication state diagram

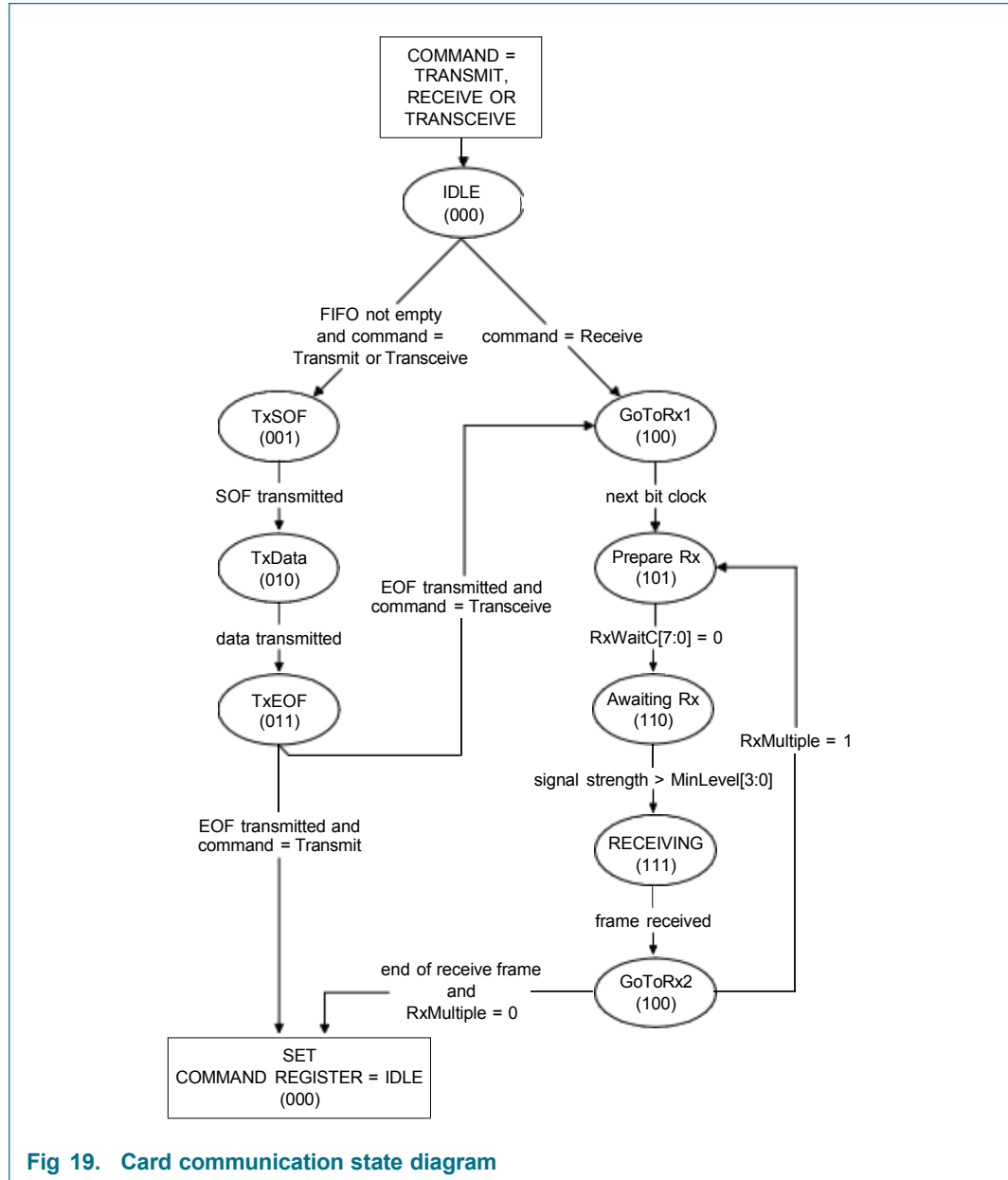

Fig 19. Card communication state diagram



11.3 I-CODE1 and ISO/IEC 15693 label communication commands

The FSV9532 is a fully ISO/IEC 14443 A, ISO/IEC 14443 B, ISO/IEC 15693 and I-CODE1 compliant reader IC. This enables the command set to be more flexible and generalized when compared to dedicated MIFARE or I-CODE1 reader ICs. [Section 11.3.1](#) to [Section 11.3.5](#) give an overview of the command set for I-CODE1 and ISO/IEC 15693 card communication and related communication protocols.

11.3.1 Transmit command 1Ah

Table 143. Transmit command 1Ah

Command	Value	Action	Arguments and data	Returned data
Transmit	1Ah	transmits data from FIFO buffer to the label	data stream	-

The Transmit command reads data from the FIFO buffer and sends it to the transmitter. It does not return any data. The Transmit command can only be started by the microprocessor.

11.3.1.1 Using the Transmit command

To transmit data, one of the following sequences can be used:

1. All data to be transmitted to the label is written to the FIFO buffer while the Idle command is active. Then the command code for the Transmit command is written to the Command register.
Remark: This is possible for transmission of a data stream up to 64 bytes long.
2. The command code for the Transmit command is stored in the Command register. Since there is not any data available in the FIFO buffer, the command is only enabled but transmission is not triggered. Data transmission starts when the first data byte is written to the FIFO buffer. To generate a continuous data stream on the RF interface, the microprocessor must write the subsequent data bytes into the FIFO buffer in time.
Remark: This allows transmission of any data stream length but it requires data to be written to the FIFO buffer in time.
3. Part of the data transmitted to the label is written to the FIFO buffer while the Idle command is active. Then the command code for the Transmit command is written to the Command register. While the Transmit command is active, the microprocessor can send further data to the FIFO buffer. This is then appended by the transmitter to the transmitted data stream.
Remark: This allows transmission of any data stream length but it requires data to be written to the FIFO buffer in time.

When the transmitter requests the next data byte, to ensure that the data stream on the RF interface is continuous and the FIFO buffer is empty, the Transmit command automatically terminates. This causes the internal state machine to change its state from transmit to idle. When the data transmission to the label is finished, the TxIRq flag is set by the FSV9532 to indicate transmission is complete to the microprocessor.

Remark: If the microprocessor overwrites the transmit code in the Command register with another command, transmission stops immediately on the next clock cycle. This can produce output signals that do not comply with the ISO/IEC 15693 standard or the I-CODE1 protocol.



11.3.1.2 RF channel redundancy and framing

Each transmitted ISO/IEC 15693 frame consists of a Start Of Frame (SOF) pattern, followed by the data stream and is closed by an End Of Frame (EOF) pattern. All I-CODE1 command frames consists of a start pulse followed by the data stream. The I-CODE1 commands have a fixed length and do not need an EOF. The phases of the transmission sequence are monitored using the PrimaryStatus register's ModemState[2:0] bits; see Section 11.2.4 on page 85.

Depending on the ChannelRedundancy register TxCRCEn bit setting, the CRC is calculated and appended to the data stream. The CRC is calculated using the ChannelRedundancy register settings.

11.3.1.3 Transmission of frames of more than 64 bytes

To generate frames of more than 64 bytes of data, the microprocessor has to write data to the FIFO buffer while the Transmit command is active. The state machine checks the FIFO buffer status when it starts transmitting the last bit of the data stream (the check time is shown in Figure 20 with arrows).

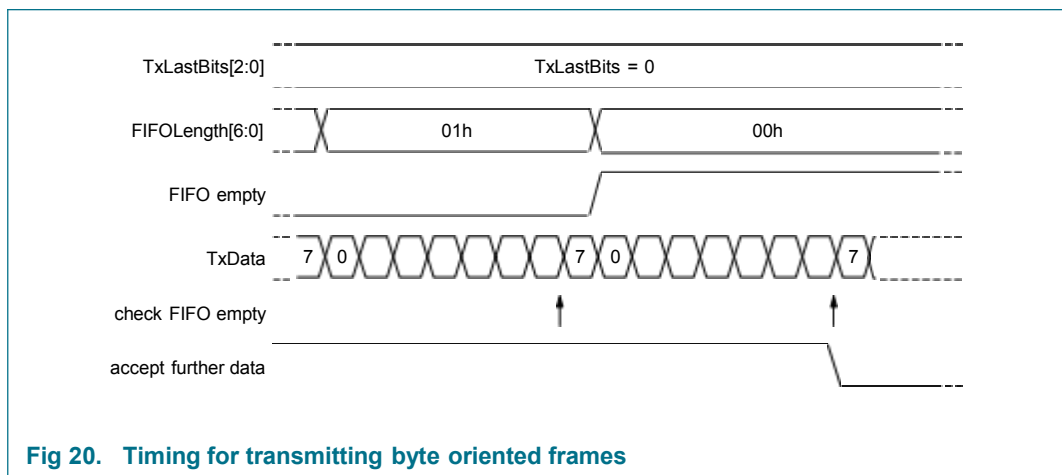

Fig 20. Timing for transmitting byte oriented frames

As long as the internal accept further data signal is logic 1 further data can be written to the FIFO buffer. The FSV9532 appends this data to the data stream transmitted using the RF interface.

If the internal accept further data signal is logic 0 the transmission terminates. All data written to the FIFO buffer after accept further data signal was set to logic 0 is not transmitted, however, it remains in the FIFO buffer.

11.3.2 Receive command 16h

Table 144. Receive command 16h

Command	Value	Action	Arguments and data	Returned data
Receive	16h	activates receiver circuitry	-	data stream

The Receive command activates the receiver circuitry. All data received from the RF interface is written to the FIFO buffer. The Receive command can be started either by the microprocessor or automatically during execution of the Transceive command.



Remark: This command may be used for test purposes only, since there is no timing relation to the Transmit command.

11.3.2.1 Using the Receive command

After starting the Receive command the internal state machine decrements the RxWait register value on every bit-clock. The analog receiver circuitry is prepared and activated from 3 down to 1. When the counter reaches 0, the receiver starts monitoring the incoming signal using the RF interface. If the signal strength reaches a level above the value set in the RxThreshold register's MinLevel[3:0] bits, the receiver starts decoding. The decoder stops when the signal cannot be detected on the receiver input pin RX. The decoder sets the RxIRq flag bit to indicate that the operation has finished.

The receive sequence phases can be monitored using bits ModemStatus[2:0] in the PrimaryStatus register; see [Section 11.2.4 on page 85](#).

Remark: The minimum value for RxWait[7:0] is 3 because counter values from 3 to 0 are needed to initialize the analog receiver circuitry.

11.3.2.2 RF channel redundancy and framing

In ISO/IEC 15693 mode, the decoder expects a SOF pattern at the beginning of each data stream. When a SOF is detected, it activates the serial-to-parallel converter and gathers the incoming data bits. If an EOF pattern (ISO/IEC 15693) is detected or the signal strength falls below the MinLevel value, the receiver and the decoder stop, the Idle command is entered and an appropriate response for the microprocessor is generated (interrupt request activated, status flags set).

In I-CODE1 mode, the decoder does not expect a SOF pattern at the beginning of each data stream. It activates the serial-to-parallel converter on the first received bit of the data. Every full byte is then sent to the FIFO buffer.

If ChannelRedundancy register bit RxCRCEn is set a CRC block is expected. The CRC block may be one byte or two bytes based on the ChannelRedundancy register's CRC8 bit.

Remark: If it is correct, the CRC block is not forwarded to the FIFO buffer. The CRC is realized by shifting the incoming data bytes through an internal buffer of one or two bytes (depending on the defined CRC). The CRC block remains in this internal buffer. Consequently, all data bytes in the FIFO buffer are delayed by one or two bytes. If the CRC fails, all bytes received are forwarded to the FIFO buffer (including the faulty CRC).

11.3.2.3 Collision detection

If more than one label is within the RF field during the label selection phase, they will respond simultaneously. The FSV9532 supports the algorithm defined in ISO/IEC 15693 as well as the I-CODE1 anti-collision algorithm to resolve label serial number data collisions using the anti-collision procedure. The basis for this procedure is the ability to detect bit-collisions.

Bit-collision detection is supported by the Manchester coding bit encoding scheme used. If in the first and second half-bit of a bit a subcarrier modulation is detected, instead of forwarding a 1-bit or a 0-bit, a bit-collision is flagged.



To distinguish between a 1-bit or 0-bit from a bit-collision, the RxThreshold register's CollLevel[3:0] value is used. If the amplitude of the half-bit with smaller amplitude is larger than defined by CollLevel[3:0], a bit-collision is flagged by setting the CollErr error flag.

The receiver continues receiving the incoming data stream independently from the detected collision. In case of a bit-collision, the decoder forwards logic 1 at the collision position.

Remark: As an exception, if bit ZeroAfterColl is set, all bits received after the first bit-collision are forced to zero, regardless of whether a bit-collision or an unequivocal state has been detected. This feature makes it easier for the software to carry out the anti-collision procedure as defined in ISO/IEC 15693.

When the first bit-collision in a frame is detected, the bit position of the collision is stored in the CollPos register.

The collision positions are shown in [Table 145](#).

Table 145. Return values for bit-collision positions

Collision in bit	CollPos register value (Decimal)
SOF	0
Least Significant Bit (LSB) of the Least Significant Byte (LSByte)	1
...	...
Most Significant Bit (MSB) of the LSByte	8
LSB of second byte	9
...	...
MSB of second byte	16
LSB of third byte	17
...	...

If a collision is detected in the SOF, a frame error is reported and no data is sent to the FIFO buffer. In this case the receiver continues to monitor the incoming signal and generates the correct notifications to the microprocessor when the end of the faulty input stream is detected. This helps the microprocessor to determine the time when it is next allowed to send data to the label.

11.3.2.4 Communication errors

[Table 146](#) shows the events that set error flags.

Table 146. Communication error table

Cause	Bit set
Received data did not start with a SOF pattern	FramingErr
CRC block is not equal to the expected value	CRCErr
Received data is shorter than the CRC block	CRCErr
A collision is detected	CollErr



11.3.3 Transceive command 1Eh

Table 147. Transceive command 1Eh

Command	Value	Action	Arguments and data	Returned data
Transceive	1Eh	transmits data from FIFO buffer to the label and then activates the receiver	data stream	data stream

The Transceive command first executes the Transmit command (see [Section 11.2.1 on page 79](#)) and then starts the Receive command (see [Section 11.2.2 on page 82](#)). All data to be transmitted is sent using the FIFO buffer and all received data is written to the FIFO buffer. The Transceive command can be started only by the microprocessor.

Remark: To adjust the timing relationship between transmitting and receiving, use the RxWait register. This enables the time delay from the last bit transmitted until the receiver is activated to be defined. The BitPhase register is used to set-up the phase-shift between the transmitter and the receiver clock.

11.3.4 Label communication states

The status of the transmitter and receiver state machine can be read from the PrimaryStatus register ModemState[2:0] bits. The assignment of ModemState[2:0] to the internal action is shown in [Table 148](#).

Table 148. ModemState values

ModemState [2:0]	Name	Description
000	Idle	transmitter and/or receiver are not operating
001	TxSOF	transmitting the start of frame pattern
010	TxData	transmitting data from the FIFO buffer (or CRC check bits)
011	TxEOF	transmitting the end of frame pattern
100	GoToRx1	intermediate state passed, when receiver starts
	GoToRx2	intermediate state passed, when receiver finishes
101	PrepareRx	waiting until the RxWait register wait time has elapsed
110	AwaitingRx	receiver activated; awaiting an input signal on pin RX
111	Receiving	receiving data



11.3.5 Label communication state diagram

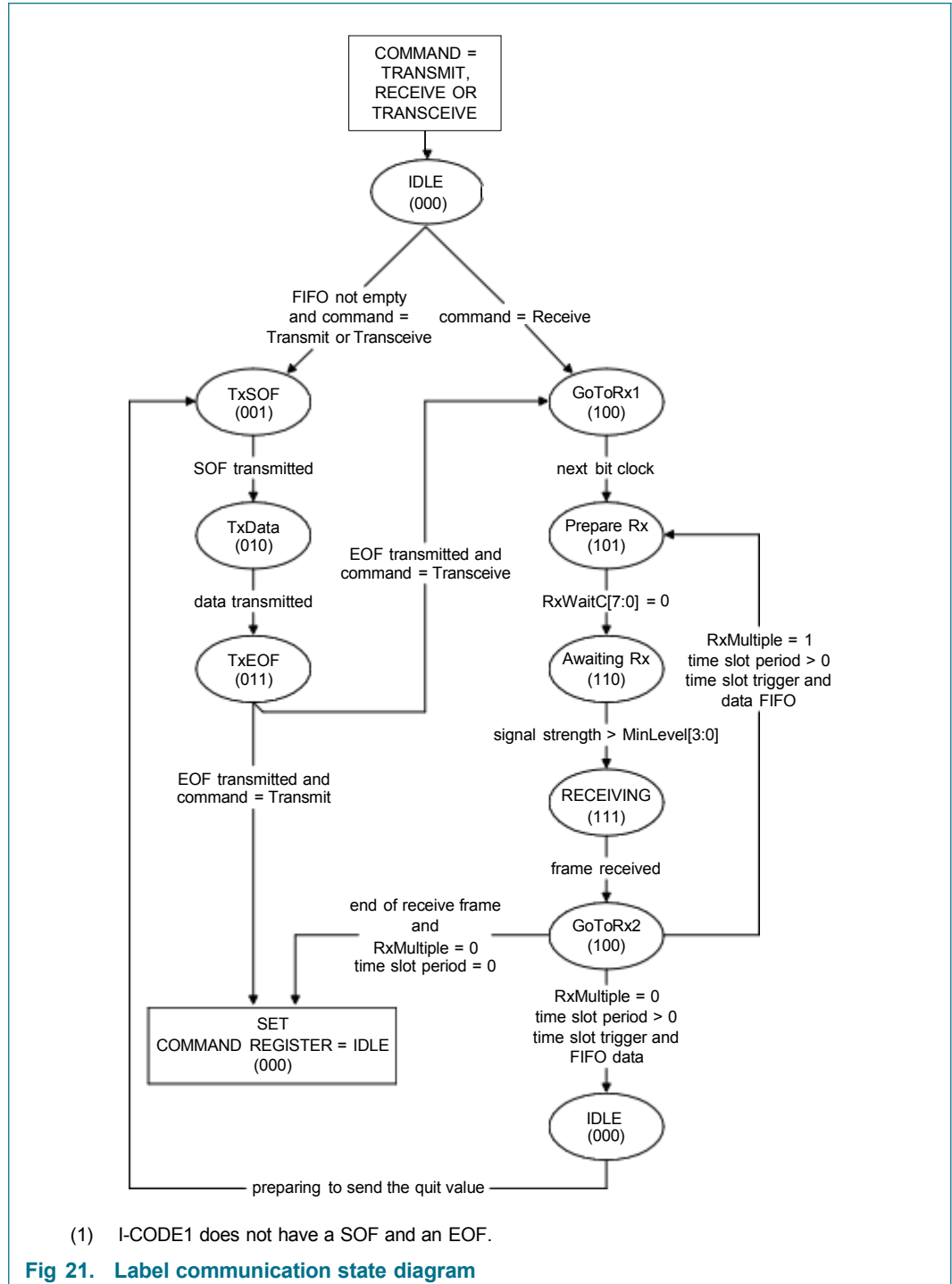



11.4 EEPROM commands

11.4.1 WriteE2 command 01h

Table 149. WriteE2 command 01h

Command	Value	Action	FIFO	
			Arguments and data	Returned data
WriteE2	01h	get data from FIFO buffer and write it to the EEPROM	start address LSB	-
			start address MSB	-
			data byte stream	-

The WriteE2 command interprets the first two bytes in the FIFO buffer as the EEPROM start byte address. Any further bytes are interpreted as data bytes and are programmed into the EEPROM, starting from the given EEPROM start byte address. This command does not return any data.

The WriteE2 command can only be started by the microprocessor. It will not stop automatically but has to be stopped explicitly by the microprocessor by issuing the Idle command.

11.4.1.1 Programming process

One byte up to 16-byte can be programmed into the EEPROM during a single programming cycle. The time needed is approximately 5.8 ms.

The state machine copies all the prepared data bytes to the FIFO buffer and then to the EEPROM input buffer. The internal EEPROM input buffer is 16 bytes long which is equal to the block size of the EEPROM. A programming cycle is started if the last position of the EEPROM input buffer is written or if the last byte of the FIFO buffer has been read.

The E2Ready flag remains logic 0 when there are unprocessed bytes in the FIFO buffer or the EEPROM programming cycle is still in progress. When all the data from the FIFO buffer are programmed into the EEPROM, the E2Ready flag is set to logic 1. Together with the rising edge of E2Ready the TxIRq interrupt request flag shows logic 1. This can be used to generate an interrupt when programming of all data is finished.

Remark: During the EEPROM programming indicated by E2Ready = logic 0, the WriteE2 command cannot be stopped using any other command.

Once E2Ready = logic 1, the WriteE2 command can be stopped by the microprocessor by sending the Idle command.



11.4.1.2 Timing diagram

Figure 22 shows programming five bytes into the EEPROM.

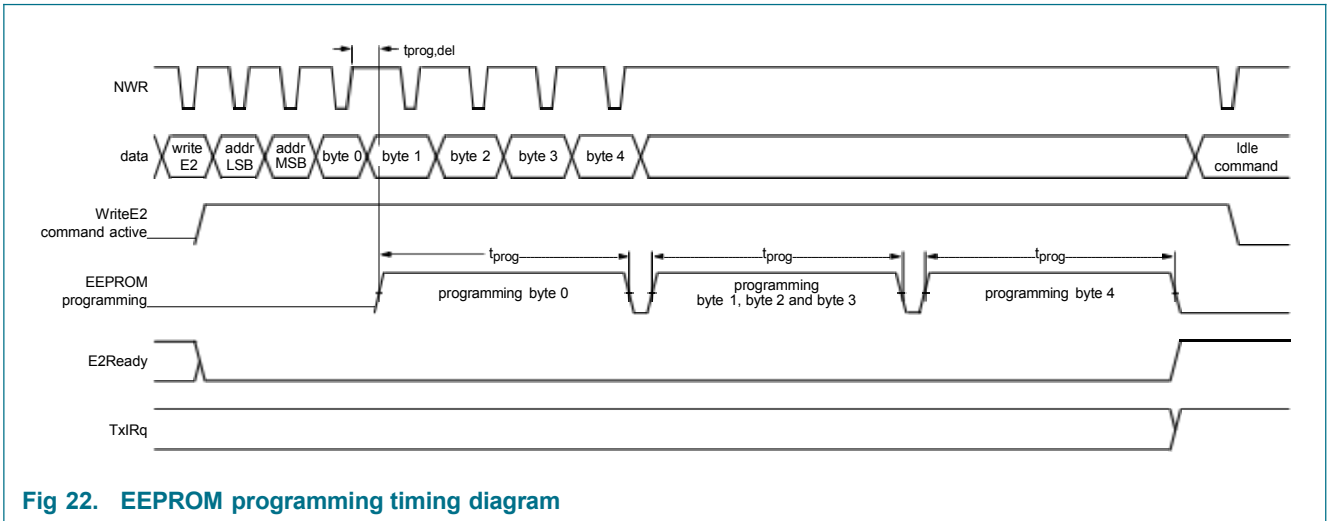

Fig 22. EEPROM programming timing diagram

Assuming that the FSV9532 finds and reads byte 0 before the microprocessor is able to write byte 1 ($t_{prog,del} = 300$ ns). This causes the FSV9532 to start the programming cycle (t_{prog}), which takes approximately 5.8 ms to complete. In the meantime, the microprocessor stores byte 1 to byte 4 in the FIFO buffer.

If the EEPROM start byte address is 16Ch then byte 0 is stored at that address. The FSV9532 copies the subsequent data bytes into the EEPROM input buffer. Whilst copying byte 3, it detects that this data byte has to be programmed at the EEPROM byte address 16Fh. As this is the end of the memory block, the FSV9532 automatically starts a programming cycle.

Next, byte 4 is programmed at the EEPROM byte address 170h. As this is the last data byte, the E2Ready and TxIRq flags are set indicating the end of the EEPROM programming activity.

Although all data has been programmed into the E2PROM, the FSV9532 stays in the WriteE2 command. Writing more data to the FIFO buffer would lead to another EEPROM programming cycle continuing from EEPROM byte address 171h. The command is stopped using the Idle command.

11.4.1.3 WriteE2 command error flags

Programming is restricted for EEPROM block 0 (EEPROM byte address 00h to 0Fh). If you program these addresses, the AccessErr flag is set and a programming cycle is not started.

Addresses above 1FFh are taken modulo 200h; see Section 9.2 on page 12 for the EEPROM memory organization.



11.4.2 ReadE2 command 03h

Table 150. ReadE2 command 03h

Command	Value	Action	Arguments	Returned data
ReadE2	03h	reads EEPROM data and stores it in the FIFO buffer	start address LSB	data bytes
			start address MSB	
			number of data bytes	

The ReadE2 command interprets the first two bytes stored in the FIFO buffer as the EEPROM starting byte address. The next byte specifies the number of data bytes returned.

When all three argument bytes are available in the FIFO buffer, the specified number of data bytes is copied from the EEPROM into the FIFO buffer, starting from the given EEPROM starting byte address.

The ReadE2 command can only be triggered by the microprocessor and it automatically stops when all data has been copied.

11.4.2.1 ReadE2 command error flags

Reading is restricted to EEPROM blocks 8h to 1Fh (key memory area). Reading from these addresses sets the flag AccessErr = logic 1.

Addresses above 1FFh are taken as modulo 200h; see [Section 9.2 on page 12](#) for the EEPROM memory organization.

11.5 Diverse commands

11.5.1 LoadConfig command 07h

Table 151. LoadConfig command 07h

Command	Value	Action	Arguments and data	Returned data
LoadConfig	07h	reads data from EEPROM and initializes the registers	start address LSB	-
			start address MSB	-

The LoadConfig command interprets the first two bytes found in the FIFO buffer as the EEPROM starting byte address. When the two argument bytes are available in the FIFO buffer, 32 bytes from the EEPROM are copied into the Control and other relevant registers, starting at the EEPROM starting byte address. The LoadConfig command can only be started by the microprocessor and it automatically stops when all relevant registers have been copied.

11.5.1.1 Register assignment

The 32 bytes of EEPROM content are written to the FSV9532 registers 10h to register 2Fh; see [Section 9.2 on page 12](#) for the EEPROM memory organization.

Remark: The procedure for the register assignment is the same as it is for the startup initialization (see [Section 9.7.3 on page 30](#)). The difference is, the EEPROM starting byte address for the startup initialization is fixed to 10h (block 1, byte 0). However, it can be chosen with the LoadConfig command.



11.5.1.2 Relevant LoadConfig command error flags

Valid EEPROM starting byte addresses are between 10h and 60h.

Copying from block 8h to 1Fh (keys) is restricted. Reading from these addresses sets the flag AccessErr = logic 1.

Addresses above 1FFh are taken as modulo 200h; see [Section 9.2 on page 12](#) for the EEPROM memory organization.

11.5.2 CalcCRC command 12h

Table 152. CalcCRC command 12h

Command	Value	Action	Arguments and data	Returned data
CalcCRC	12h	activates the CRC coprocessor	data byte stream	-

The CalcCRC command takes all the data from the FIFO buffer as the input bytes for the CRC coprocessor. All data stored in the FIFO buffer before the command is started is processed.

This command does not return any data to the FIFO buffer but the content of the CRC can be read using the CRCResultLSB and CRCResultMSB registers.

The CalcCRC command can only be started by the microprocessor and it does not automatically stop. It must be stopped by the microprocessor sending the Idle command. If the FIFO buffer is empty, the CalcCRC command waits for further input before proceeding.

11.5.2.1 CRC coprocessor settings

Table 153 shows the parameters that can be configured for the CRC coprocessor.

Table 153. CRC coprocessor parameters

Parameter	Value	Bit	Register
CRC register length	8-bit or 16-bit CRC	CRC8	ChannelRedundancy
CRC algorithm	ISO/IEC 14443 A or ISO/IEC 3309	CRC3309	ChannelRedundancy
CRC preset value	any	CRCPresetLSB	CRCPresetLSB
		CRCPresetMSB	CRCPresetMSB

The CRC polynomial for the 8-bit CRC is fixed to $x^8 + x^4 + x^3 + x^2 + 1$.

The CRC polynomial for the 16-bit CRC is fixed to $x^{16} + x^{12} + x^5 + 1$.

11.5.2.2 CRC coprocessor status flags

The CRCReady status flag indicates that the CRC coprocessor has finished processing all the data bytes in the FIFO buffer. When the CRCReady flag is set to logic 1, an interrupt is requested which sets the TxIRq flag. This supports interrupt driven use of the CRC coprocessor.

When CRCReady and TxIRq flags are set to logic 1 the content of the CRCResultLSB and CRCResultMSB registers and the CRCErr flag are valid. The CRCResultLSB and CRCResultMSB registers hold the content of the CRC, the CRCErr flag indicates CRC validity for the processed data.



11.6 Error handling during command execution

If an error is detected during command execution, the PrimaryStatus register Err flag is set. The microprocessor can evaluate the status flags in the ErrorFlag register to get information about the cause of the error.

Table 154. ErrorFlag register error flags overview

Error flag	Related commands
KeyErr	LoadKeyE2, LoadKey
AccessErr	WriteE2, ReadE2, LoadConfig
FIFOvlf	no specific commands
CRCErr	Receive, Transceive, CalcCRC
FramingErr	Receive, Transceive
ParityErr	Receive, Transceive
CollErr	Receive, Transceive

11.7 MIFARE security commands

11.7.1 LoadKeyE2 command 0Bh

Table 155. LoadKeyE2 command 0Bh

Command	Value	Action	Arguments and data	Returned data
LoadKeyE2	0Bh	reads a key from the EEPROM and puts it into the internal key buffer	start address LSB	-
			start address MSB	-

The LoadKeyE2 command interprets the first two bytes found in the FIFO buffer as the EEPROM starting byte address. The EEPROM bytes starting from the given starting byte address are interpreted as the key when stored in the correct key format as described in [Section 9.2.3.1 “Key format” on page 18](#). When both argument bytes are available in the FIFO buffer, the command executes.

The LoadKeyE2 command can only be started by the microprocessor and it automatically stops after copying the key from the EEPROM to the key buffer.

11.7.1.1 Relevant LoadKeyE2 command error flags

If the key format is incorrect (see [Section 9.2.3.1 “Key format” on page 18](#)) an undefined value is copied into the key buffer and the KeyErr flag is set.

11.7.2 LoadKey command 19h

Table 156. LoadKey command 19h

Command	Value	Action	Arguments and data	Returned data
LoadKey	19h	reads a key from the FIFO buffer and puts it into the key buffer	byte 0 (LSB)	-
			byte 1	-
			...	-
			byte 10	-
			byte 11 (MSB)	-



The LoadKey command interprets the first twelve bytes it finds in the FIFO buffer as the key when stored in the correct key format as described in [Section 9.2.3.1 “Key format” on page 18](#). When the twelve argument bytes are available in the FIFO buffer they are checked and, if valid, are copied into the key buffer.

The LoadKey command can only be started by the microprocessor and it automatically stops after copying the key from the FIFO buffer to the key buffer.

11.7.2.1 Relevant LoadKey command error flags

All bytes requested are copied from the FIFO buffer to the key buffer. If the key format is not correct (see [Section 9.2.3.1 “Key format” on page 18](#)) an undefined value is copied into the key buffer and the KeyErr flag is set.

11.7.3 Authent1 command 0Ch

Table 157. Authent1 command 0Ch

Command	Value	Action	Arguments and data	Returned data
Authent1	0Ch	performs the first part of the Crypto1 card authentication	card Authent1 command	-
			card block address	-
			card serial number LSB	-
			card serial number byte1	-
			card serial number byte2	-
			card serial number MSB	-

The Authent1 command is a special Transceive command; it sends six argument bytes to the card. The card's response is not sent to the microprocessor, it is used instead to authenticate the card to the FSV9532 and vice versa.

The Authent1 command can be triggered only by the microprocessor. The sequence of states for this command are the same as those for the Transceive command; see [Section 11.2.3 on page 85](#).

11.7.4 Authent2 command 14h

Table 158. Authent2 command 14h

Command	Value	Action	Arguments and data	Returned data
Authent2	14h	performs the second part of the card authentication using the Crypto1 algorithm	-	-

The Authent2 command is a special Transceive command. It does not need any argument byte, however all the data needed to be sent to the card is assembled by the FSV9532. The card response is not sent to the microprocessor but is used to authenticate the card to the FSV9532 and vice versa.

The Authent2 command can only be started by the microprocessor. The sequence of states for this command are the same as those for the Transceive command; see [Section 11.2.3 on page 85](#).



11.7.4.1 Authent2 command effects

If the Authent2 command is successful, the authenticity of card and the FSV9532 are proved. This automatically sets the Crypto1On control bit. When bit Crypto1On = logic 1, all further card communication is encrypted using the Crypto1 security algorithm. If the Authent2 command fails, bit Crypto1On is cleared (Crypto1On = logic 0).

Remark: The Crypto1On flag can only be set by a successfully executed Authent2 command and not by the microprocessor. The microprocessor can clear bit Crypto1On to continue with unencrypted (plain) card communication.

Remark: The Authent2 command must be executed immediately after a successful Authent1 command; see [Section 11.7.3 “Authent1 command 0Ch”](#). In addition, the keys stored in the key buffer and those on the card must match.

12. Limiting values

Table 159. Limiting values

In accordance with the Absolute Maximum Rating System (IEC 60134).

Symbol	Parameter	Conditions	Min	Max	Unit
T_{amb}	ambient temperature		-40	+150	°C
T_{stg}	storage temperature		-40	+150	°C
V_{DDD}	digital supply voltage		-0.5	+6	V
V_{DDA}	analog supply voltage		-0.5	+6	V
$V_{DD(TVDD)}$	TVDD supply voltage		-0.5	+6	V
V_i	input voltage (absolute value)	on any digital pin to DVSS	-0.5	$V_{DDD} + 0.5$	V
		on pin RX to AVSS	-0.5	$V_{DDA} + 0.5$	V

13. Characteristics

13.1 Operating condition range

Table 160. Operating condition range

Symbol	Parameter	Conditions	Min	Typ	Max	Unit
T_{amb}	ambient temperature	-	-25	+25	+85	°C
V_{DDD}	digital supply voltage	DVSS = AVSS = TVSS = 0 V	3.0	3.3	3.6	V
			4.5	5.0	5.5	V
V_{DDA}	analog supply voltage	DVSS = AVSS = TVSS = 0 V	4.5	5.0	5.5	V
$V_{DD(TVDD)}$	TVDD supply voltage	DVSS = AVSS = TVSS = 0 V	3.0	5.0	5.5	V
V_{ESD}	electrostatic discharge voltage	Human Body Model (HBM); 1.5 k Ω , 100 pF	-	-	1000	V
		Machine Model (MM); 0.75 μ H, 200 pF	-	-	100	V



13.2 Current consumption

Table 161. Current consumption

Symbol	Parameter	Conditions	Min	Typ	Max	Unit
I _{DDD}	digital supply current	Idle command	-	8	11	mA
		Standby mode	-	3	5	mA
		Soft power-down mode	-	800	1000	μA
		Hard power-down mode	-	1	10	μA
I _{DDA}	analog supply current	Idle command; receiver on	-	25	40	mA
		Idle command; receiver off	-	12	15	mA
		Standby mode	-	10	13	mA
		Soft power-down mode	-	1	10	μA
		Hard power-down mode	-	1	10	μA
I _{DD(TVDD)}	TVDD supply current	continuous wave	-	-	150	mA
		pins TX1 and TX2 unconnected; TX1RFEn and TX2RFEn = logic 1	-	5.5	7	mA
		pins TX1 and TX2 unconnected; TX1RFEn and TX2RFEn = logic 0	-	65	130	μA

13.3 Pin characteristics

13.3.1 Input pin characteristics

Pins D0 to D7, A0, and A1 have TTL input characteristics and behave as defined in Table 162.

Table 162. Standard input pin characteristics

Symbol	Parameter	Conditions	Min	Typ	Max	Unit
I _{LI}	input leakage current		- 1.0	-	+1.0	μA
V _{th}	threshold voltage	CMOS: V _{DDD} < 3.6 V	0.35V _{DDD}	-	0.65V _{DDD}	V
		TTL: 4.5 < V _{DDD}	0.8	-	2.0	V

The digital input pins NCS, NWR, NRD, ALE, A2, and MFIN have Schmitt trigger characteristics, and behave as defined in Table 163.

Table 163. Schmitt trigger input pin characteristics

Symbol	Parameter	Conditions	Min	Typ	Max	Unit
I _{LI}	input leakage current		- 1.0	-	+1.0	μA
V _{th}	threshold voltage	positive-going threshold; TTL = 4.5 < V _{DDD}	1.4	-	2.0	V
		CMOS = V _{DDD} < 3.6 V	0.65V _{DDD}	-	0.75V _{DDD}	V
		negative-going threshold; TTL = 4.5 < V _{DDD}	0.8	-	1.3	V
		CMOS = V _{DDD} < 3.6 V	0.25V _{DDD}	-	0.4V _{DDD}	V



Pin RSTPD has Schmitt trigger CMOS characteristics. In addition, it is internally filtered by a RC low-pass filter which causes a propagation delay on the reset signal.

Table 164. RSTPD input pin characteristics

Symbol	Parameter	Conditions	Min	Typ	Max	Unit
I_{LI}	input leakage current		-1.0	-	+1.0	μ A
V_{th}	threshold voltage	positive-going threshold; CMOS = $V_{DDDD} < 3.6$ V	0.65 V_{DDDD}	-	0.75 V_{DDDD}	V
		negative-going threshold; CMOS = $V_{DDDD} < 3.6$ V	0.25 V_{DDDD}	-	0.4 V_{DDDD}	V
t_{PD}	propagation delay		-	-	20	μ s

The analog input pin RX has the input capacitance and input voltage range shown in [Table 165](#).

Table 165. RX input capacitance and input voltage range

Symbol	Parameter	Conditions	Min	Typ	Max	Unit
C_i	input capacitance		-	-	15	pF
$V_{i(dyn)}$	dynamic input voltage	$V_{DDA} = 5$ V; $T_{amb} = 25$ °C	1.1	-	4.4	V

13.3.2 Digital output pin characteristics

Pins D0 to D7, MFOUT and IRQ have CMOS output characteristics and behave as defined in [Table 166](#).

Table 166. Digital output pin characteristics

Symbol	Parameter	Conditions	Min	Typ	Max	Unit
V_{OH}	HIGH-level output voltage	$V_{DDDD} = 5$ V; $o_{IH} = -1$ mA	2.4	4.9	-	V
		$V_{DDDD} = 5$ V; $o_{IH} = -10$ mA	2.4	4.2	-	V
V_{OL}	LOW-level output voltage	$V_{DDDD} = 5$ V; $o_{IL} = 1$ mA	-	25	400	mV
		$V_{DDDD} = 5$ V; $o_{IL} = 10$ mA	-	250	400	mV
I_o	output current	source or sink; $V_{DDDD} = 5$ V	-	-	10	mA

Remark: Pin IRQ can be configured as open collector which causes the V_{OH} values to be no longer applicable.

13.3.3 Antenna driver output pin characteristics

The source conductance of the antenna driver pins TX1 and TX2 for driving the HIGH-level can be configured using the CwConductance register's GsCfCW[5:0] bits, while their source conductance for driving the LOW-level is constant.

The antenna driver default configuration output characteristics are specified in [Table 167](#).



Table 167. Antenna driver output pin characteristics

Symbol	Parameter	Conditions	Min	Typ	Max	Unit
VOH	HIGH-level output voltage	V _{DD(TVDD)} = 5.0 V; o _L = 20 mA	-	4.97	-	V
		V _{DD(TVDD)} = 5.0 V; o _L = 100 mA	-	4.85	-	V
VOL	LOW-level output voltage	V _{DD(TVDD)} = 5.0 V; o _L = 20 mA	-	30	-	mV
		V _{DD(TVDD)} = 5.0 V; o _L = 100 mA	-	150	-	mV
Io	output current	transmitter; continuous wave; peak-to-peak	-	-	200	mA

13.4 AC electrical characteristics

13.4.1 Separate read/write strobe bus timing

Table 168. Timing specification for separate read/write strobe

Symbol	Parameter	Conditions	Min	Typ	Max	Unit
t _{LHLL}	ALE HIGH time		20	-	-	ns
t _{AVLL}	address valid to ALE LOW time		15	-	-	ns
t _{LLAX}	address hold after ALE LOW time		8	-	-	ns
t _{LLRWL}	ALE LOW to read/write LOW time	ALE LOW to NRD or NWR LOW	15	-	-	ns
t _{SLRWL}	chip select LOW to read/write LOW time	NCS LOW to NRD or NWR LOW	0	-	-	ns
t _{RWHS}	read/write HIGH to chip select HIGH time	NRD or NWR HIGH to NCS HIGH	0	-	-	ns
t _{RLDV}	read LOW to data input valid time	NRD LOW to data valid	-	-	65	ns
t _{RHDZ}	read HIGH to data input high impedance time	NRD HIGH to data high-impedance	-	-	20	ns
t _{WLQV}	write LOW to data output valid time	NWR LOW to data valid	-	-	35	ns
t _{WHDX}	data output hold after write HIGH time	data hold time after NWR HIGH	8	-	-	ns
t _{RWLRWH}	read/write LOW time	NRD or NWR	65	-	-	ns
t _{AVRWL}	address valid to read/write LOW time	NRD or NWR LOW (set-up time)	30	-	-	ns
t _{WHAX}	address hold after write HIGH time	NWR HIGH (hold time)	8	-	-	ns
t _{RWHRWL}	read/write HIGH time		150	-	-	ns

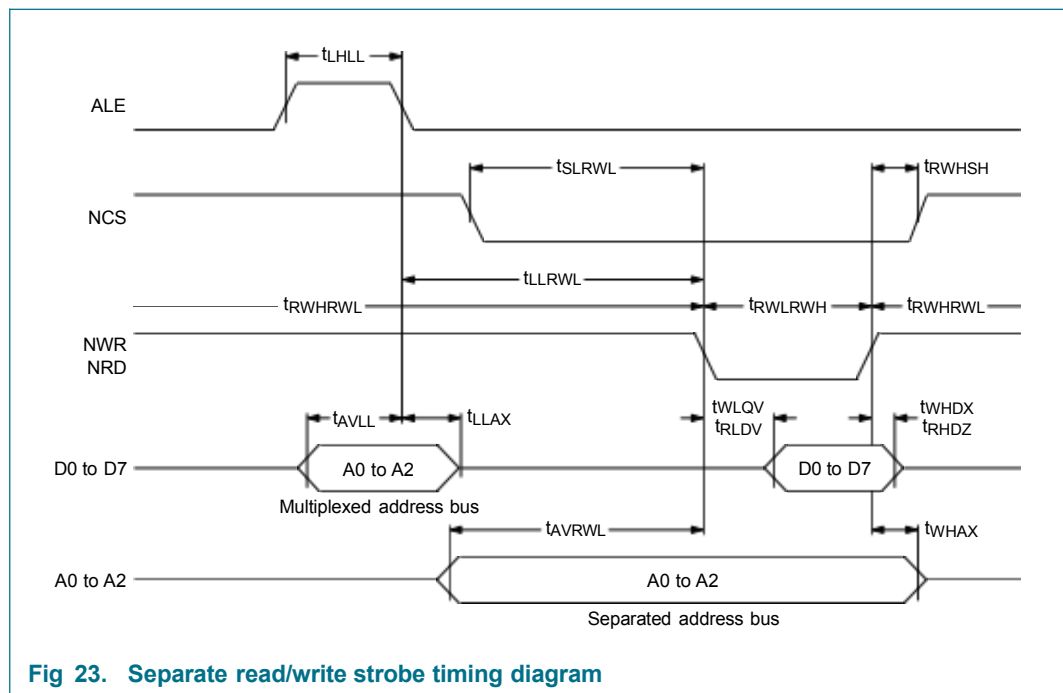

Fig 23. Separate read/write strobe timing diagram

Remark: The signal ALE is not relevant for separate address/data bus and the multiplexed addresses on the data bus do not care. The multiplexed address and data bus address lines (A0 to A2) must be connected as described in [Section 9.1.3 on page 8](#).

13.4.2 Common read/write strobe bus timing

Table 169. Common read/write strobe timing specification

Symbol	Parameter	Conditions	Min	Typ	Max	Unit
t _{LHLL}	ALE HIGH time		20	-	-	ns
t _{AVLL}	address valid to ALE LOW time		15	-	-	ns
t _{LLAX}	address hold after ALE LOW time		8	-	-	ns
t _{LLDSL}	ALE LOW to data strobe LOW time	NWR or NRD LOW	15	-	-	ns
t _{SLDSL}	chip select LOW to data strobe LOW time	NCS LOW to NDS LOW	0	-	-	ns
t _{DSSH}	data strobe HIGH to chip select HIGH time		0	-	-	ns
t _{DSLQV}	data strobe LOW to data input valid time		-	-	65	ns
t _{DSDZ}	data strobe HIGH to data input high impedance time		-	-	20	ns
t _{DSLQV}	data strobe LOW to data output valid time	NDS/NCS LOW	-	-	35	ns
t _{DSHQX}	data output hold after data strobe HIGH time	NDS HIGH (write cycle hold time)	8	-	-	ns
t _{DSHRWX}	RW hold after data strobe HIGH time	after NDS HIGH	8	-	-	ns
t _{DSLDSH}	data strobe LOW time	NDS/NCS	65	-	-	ns



Table 169. Common read/write strobe timing specification

Symbol	Parameter	Conditions	Min	Typ	Max	Unit
t_{AVDSL}	address valid to data strobe LOW time		30	-	-	ns
t_{RHAX}	address hold after read HIGH time		8	-	-	ns
t_{DSHDSL}	data strobe HIGH time	period between write sequences	150	-	-	ns
t_{WLDSL}	write LOW to data strobe LOW time	R/NW valid to NDS LOW	8	-	-	ns

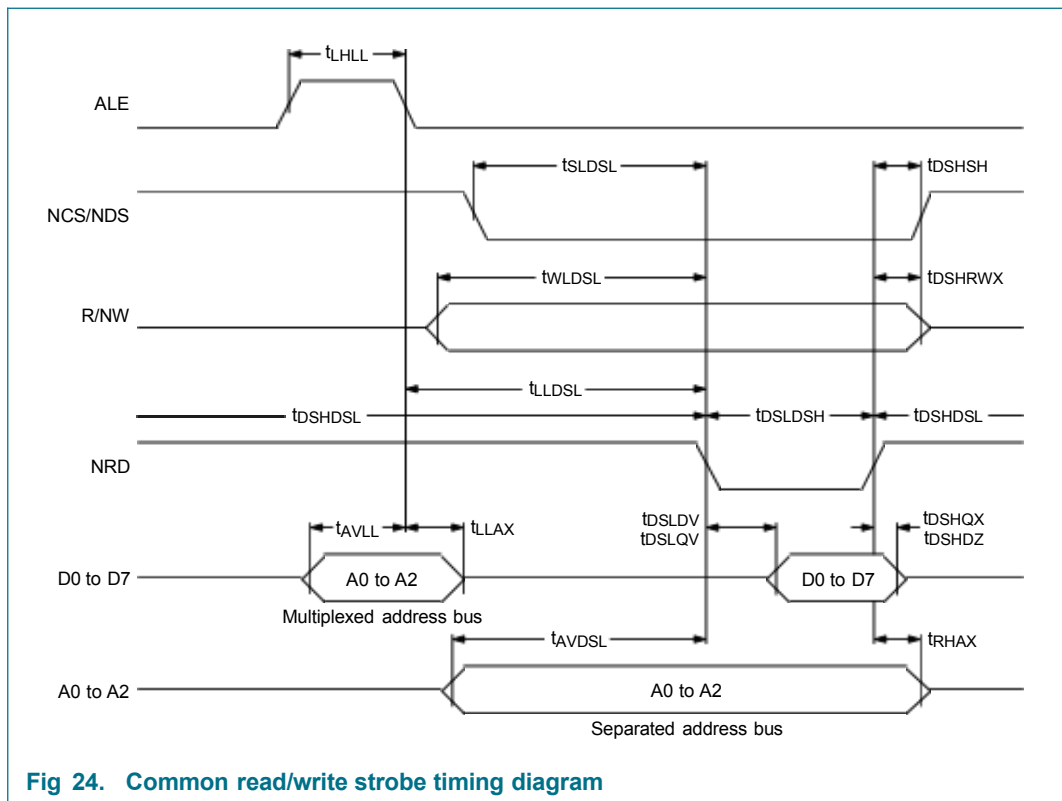

Fig 24. Common read/write strobe timing diagram

13.4.3 EPP bus timing

Table 170. Common read/write strobe timing specification for EPP

Symbol	Parameter	Conditions	Min	Typ	Max	Unit
t_{ASLASH}	address strobe LOW time	nASt r b	20	-	-	ns
t_{AVASH}	address valid to address strobe HIGH time	multiplexed address bus set-up time	15	-	-	ns
t_{ASHAV}	address valid after address strobe HIGH time	multiplexed address bus hold time	8	-	-	ns
t_{SLDSL}	chip select LOW to data strobe LOW time	NCS LOW to nDSt r b LOW	0	-	-	ns
t_{DSHSH}	data strobe HIGH to chip select HIGH time	nDSt r b HIGH to NCS HIGH	0	-	-	ns
t_{SLDV}	data strobe LOW to data input valid time	read cycle	-	-	65	ns



Table 170. Common read/write strobe timing specification for EPP

Symbol	Parameter	Conditions	Min	Typ	Max	Unit
t_{DSHDZ}	data strobe HIGH to data input high impedance time	read cycle	-	-	20	ns
t_{DSLQV}	data strobe LOW to data output valid time	nDStrb LOW	-	-	35	ns
t_{DSHQX}	data output hold after data strobe HIGH time	NCS HIGH	8	-	-	ns
t_{DSHWX}	write hold after data strobe HIGH time	nWrite	8	-	-	ns
t_{DSLDSH}	data strobe LOW time	nDStrb	65	-	-	ns
t_{WLDSL}	write LOW to data strobe LOW time	nWrite valid to nDStrb LOW	8	-	-	ns
$t_{DSL-WAITH}$	data strobe LOW to WAIT HIGH time	nDStrb LOW to nWrite HIGH	-	-	75	ns
$t_{DSH-WAITL}$	data strobe HIGH to WAIT LOW time	nDStrb HIGH to nWrite LOW	-	-	75	ns

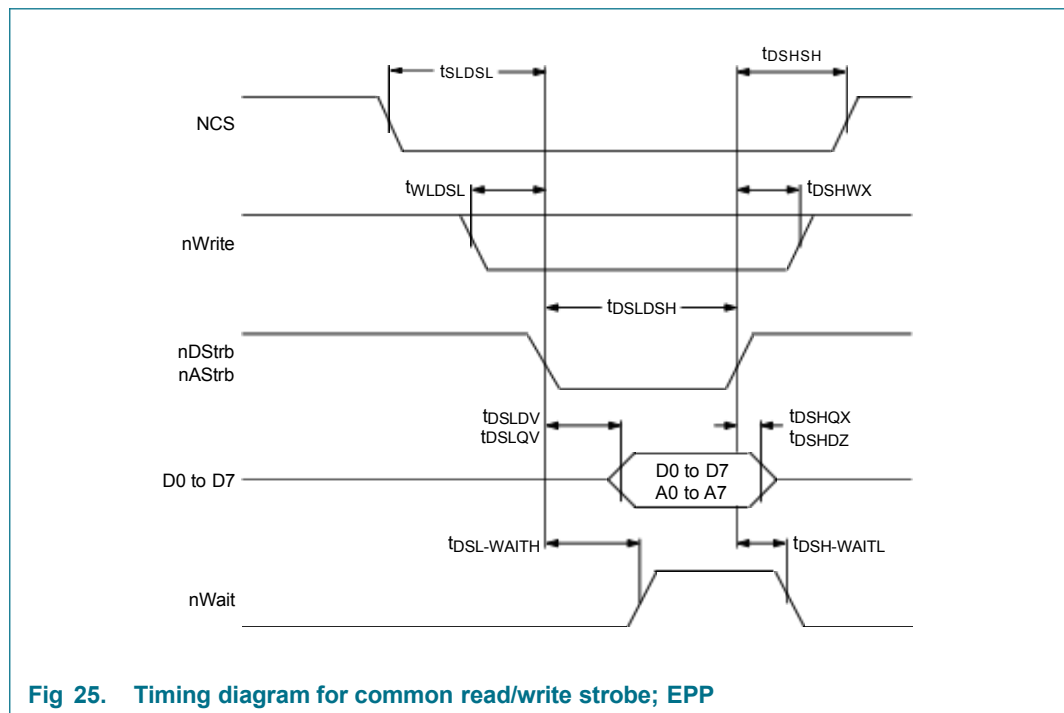

Remark: Figure 25 does not distinguish between the address write cycle and a data write cycle. The timings for the address write and data write cycle are different. In EPP mode, the address lines (A0 to A2) must be connected as described in Section 9.1.3 on page 8.



13.4.4 SPI timing

Table 171. SPI timing specification

Symbol	Parameter	Conditions	Min	Typ	Max	Unit
t_{SCKL}	SCK LOW time		100	-	-	ns
t_{SCKH}	SCK HIGH time		100	-	-	ns
t_{DSHQX}	data output hold after data strobe HIGH time		20	-	-	ns
t_{DQXCH}	data input/output changing to clock HIGH time		20	-	-	ns
$t_{h(SCKL-Q)}$	SCK LOW to data output hold time		-	-	15	ns
$t_{(SCKL-NSSH)}$	SCK LOW to NSS HIGH time		20	-	-	ns

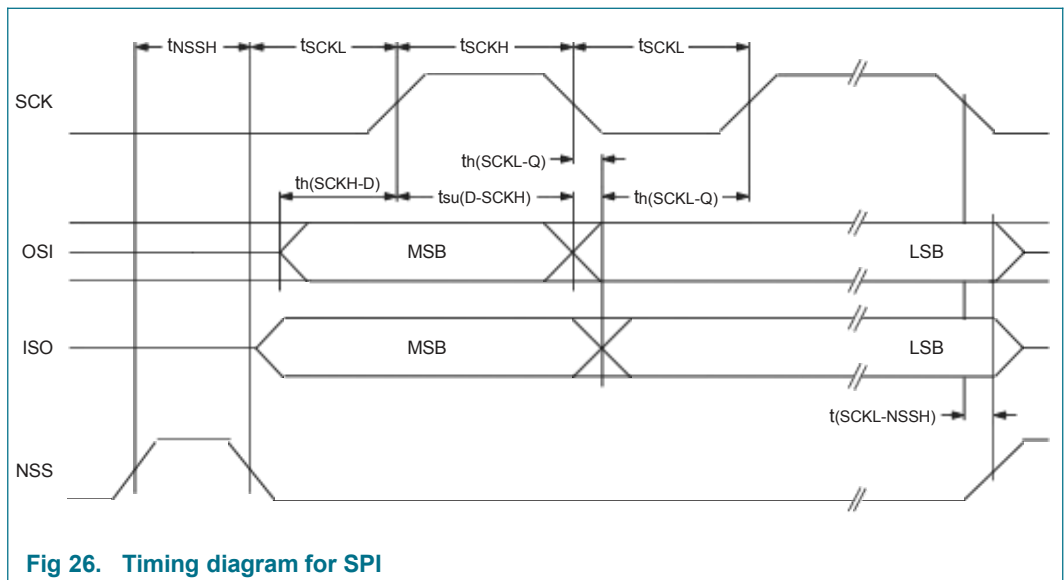

Fig 26. Timing diagram for SPI

Remark: To send more bytes in one data stream the NSS signal must be LOW during the send process. To send more than one data stream the NSS signal must be HIGH between each data stream.

13.4.5 Clock frequency

The clock input is pin OSCIN.

Table 172. Clock frequency

Symbol	Parameter	Conditions	Min	Typ	Max	Unit
f_{clk}	clock frequency	checked by the clock filter	-	13.56	-	MHz
d_{clk}	clock duty cycle		40	50	60	%
t_{jit}	jitter time	of clock edges	-	-	10	ps

The clock applied to the FSV9532 acts as a time constant for the synchronous system's encoder and decoder. The stability of the clock frequency is an important factor for ensuring proper performance. To obtain highest performance, clock jitter must be as small as possible. This is best achieved using the internal oscillator buffer and the recommended circuitry; see Section 9.8 on page 30.



14. EEPROM characteristics

The EEPROM size is $32 \times 16 \times 8 = 4096$ bit.

Table 173. EEPROM characteristics

Symbol	Parameter	Conditions	Min	Typ	Max	Unit
$N_{\text{endu(W ER)}}$	write or erase endurance	erase/write cycles	100.000	-	-	Hz
t_{ret}	retention time	$T_{\text{amb}} \leq 55 \text{ }^\circ\text{C}$	10	-	-	year
t_{er}	erase time		-	-	2.9	ms
$t_{\text{a(W)}}$	write access time		-	-	2.9	ms

15. Application information

15.1 Typical application

15.1.1 Circuit diagram

Figure 27 shows a typical application where the antenna is directly matched to the FSV9532:

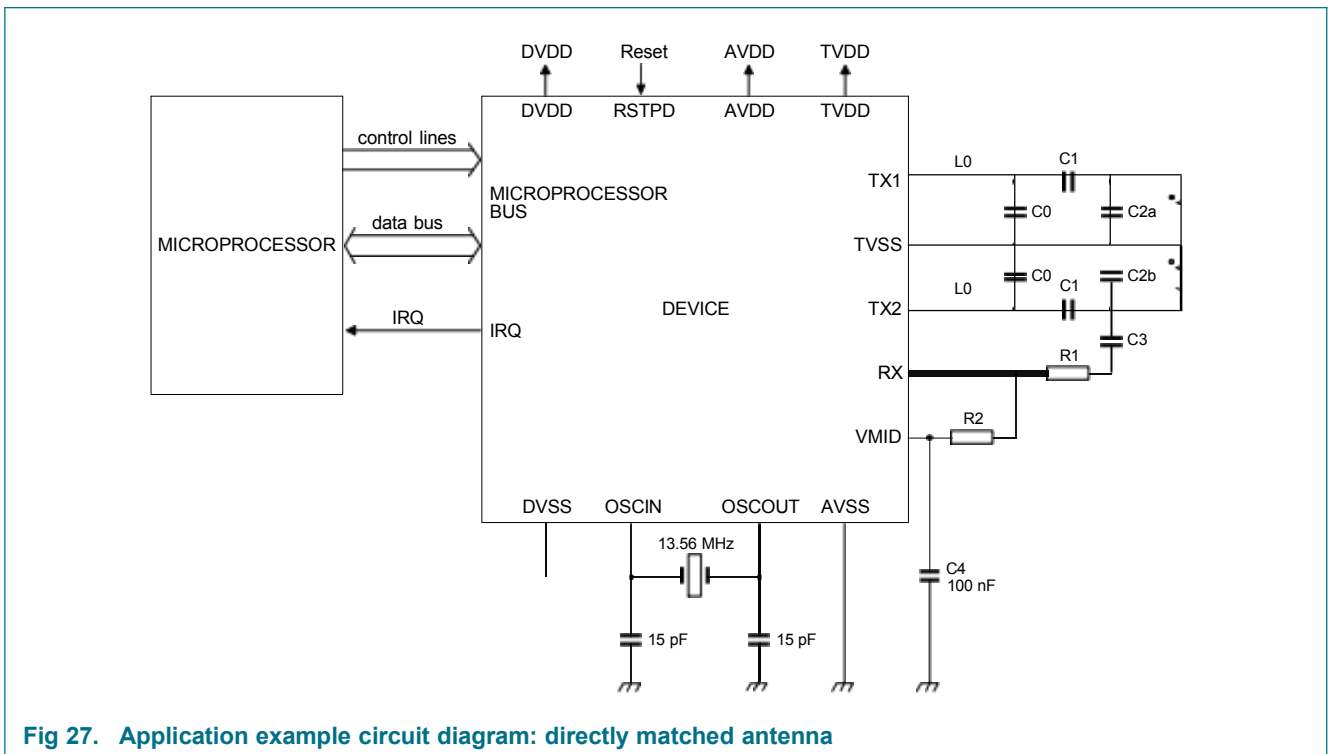

Fig 27. Application example circuit diagram: directly matched antenna



15.1.2 Circuit description

The matching circuit consists of an EMC low-pass filter (L0 and C0), matching circuitry (C1 and C2), a receiver circuit (R1, R2, C3 and C4) and the antenna itself.

Refer to the following application notes for more detailed information about designing and tuning an antenna.

- *MICORE reader IC family; Directly Matched Antenna Design* [Ref. 1](#)
- *MIFARE (14443 A) 13.56 MHz RFID Proximity Antennas* [Ref. 2](#).

15.1.2.1 EMC low-pass filter

The MIFARE system operates at a frequency of 13.56 MHz. This frequency is generated by a quartz oscillator to clock the FSV9532. It is also the basis for driving the antenna using the 13.56 MHz energy carrier. This not only causes power emissions at 13.56 MHz, it also emits power at higher harmonics. International EMC regulations define the amplitude of the emitted power over a broad frequency range. To meet these regulations, appropriate filtering of the output signal is required.

A multilayer board is recommended to implement a low-pass filter as shown in [Figure 27](#). The low-pass filter consists of the components L0 and C0. The recommended values are given in Application notes *MICORE reader IC family; Directly Matched Antenna Design* [Ref. 1](#) and *MIFARE (14443 A) 13.56 MHz RFID Proximity Antennas* [Ref. 2](#).

Remark: To achieve best performance, all components must be at least equal in quality to those recommended.

Remark: The layout has a major influence on the overall performance of the filter.

15.1.2.2 Antenna matching

Due to the impedance transformation of the low-pass filter, the antenna coil has to be matched to a given impedance. The matching elements C1 and C2 can be estimated and have to be fine tuned depending on the design of the antenna coil.

The correct impedance matching is important to ensure optimum performance. The overall quality factor has to be considered to guarantee a proper ISO/IEC 14443 A and ISO/IEC 14443 B communication schemes. Environmental influences have to be considered and common EMC design rules.

Refer to Application notes *MICORE reader IC family; Directly Matched Antenna Design* [Ref. 1](#) and *MIFARE (14443 A) 13.56 MHz RFID Proximity Antennas* [Ref. 2](#) for details.

Remark: Do not exceed the current limits ($I_{DD(TVDD)}$), otherwise the chip might be destroyed.

Remark: The overall 13.56 MHz RFID proximity antenna design in combination with the FSV9532 IC does not require any specialist RF knowledge. However, all relevant parameters have to be considered to guarantee optimum performance and international EMC compliance.

15.1.2.3 Receiver circuit

The internal receiver of the FSV9532 makes use of both subcarrier load modulation side-bands. No external filtering is required.



It is recommended to use the internally generated VMID potential as the input potential for pin RX. This VMID DC voltage level has to be coupled to pin RX using resistor (R2). To provide a stable DC reference voltage, a capacitor (C4) must be connected between VMID and ground.

The AC voltage divider of R1 + C3 and R2 has to be designed taking in to account the AC voltage limits on pin RX. Depending on the antenna coil design and the impedance, matching the voltage at the antenna coil will differ. Therefore the recommended way to design the receiver circuit is to use the given values for R1, R2, and C3; refer to Application note; *MIFARE (14443 A) 13.56 MHz RFID Proximity Antennas* Ref. 2. The voltage on pin RX can be altered by varying R1 within the given limits.

Remark: R2 is AC connected to ground using C4.

15.1.2.4 Antenna coil

The precise calculation of the antenna coil's inductance is not practicable but the inductance can be estimated using Equation 10. We recommend designing an antenna that is either circular or rectangular.

$$L_1 \text{ [nH]} = 2l_1 \text{ [cm]} \cdot \left(\ln \left(\frac{l_1}{D_1} \right) - K \right) N_1^{1.8}$$

- l_1 = length of one turn of the conductor loop
- D_1 = diameter of the wire or width of the PCB conductor, respectively
- K = antenna shape factor ($K = 1.07$ for circular antennas and $K = 1.47$ for square antennas)
- N_1 = number of turns
- \ln = natural logarithm function

The values of the antenna inductance, resistance, and capacitance at 13.56 MHz depend on various parameters such as:

- antenna construction (type of PCB)
- thickness of conductor
- distance between the windings
- shielding layer
- metal or ferrite in the near environment

Therefore a measurement of these parameters under real life conditions or at least a rough measurement and a tuning procedure is highly recommended to guarantee a reasonable performance. Refer to Application notes *MICORE reader IC family; Directly Matched Antenna Design* Ref. 1 and *MIFARE (14443 A) 13.56 MHz RFID Proximity Antennas* Ref. 2 for details.



15.2 Test signals

The FSV9532 allows different kinds of signal measurements. These measurements can be used to check the internally generated and received signals using the serial signal switch as described in [Section 9.11 on page 37](#).

In addition, the FSV9532 enables users to select between:

- internal analog signals for measurement on pin AUX
- internal digital signals for observation on pin MFOUT (based on register selections)

These measurements can be helpful during the design-in phase to optimize the receiver's behavior, or for test purposes.

15.2.1 Measurements using the serial signal switch

Using the serial signal switch on pin MFOUT, data is observed that is sent to the card or received from the card. [Table 174](#) gives an overview of the different signals available.

Table 174. Signal routed to pin MFOUT

SignalToMFOUT	MFOUTSelect	Signal routed to pin MFOUT
0	0	LOW
0	1	HIGH
0	2	envelope
0	3	transmit NRZ
0	4	Manchester with subcarrier
0	5	Manchester
0	6	reserved
0	7	reserved
1	X	digital test signal

Remark: The routing of the Manchester or the Manchester with subcarrier signal to pin MFOUT is only possible at 106 kBd based on ISO/IEC 14443 A.

15.2.1.1 TX control

[Figure 28](#) shows as an example of an ISO/IEC 14443 A communication.

The signal is measured on pin MFOUT using the serial signal switch to control the data sent to the card. Setting the flag `MFOUTSelect[2:0] = 3` sends the data to the card coded as NRZ. Setting `MFOUTSelect[2:0] = 2` shows the data as a Miller coded signal.

The RFOut signal is measured directly on the antenna and gives the RF signal pulse shape. Refer to Application note *Directly matched Antenna - Excel calculation* ([Ref. 3](#)) for detail information on the RF signal pulse.

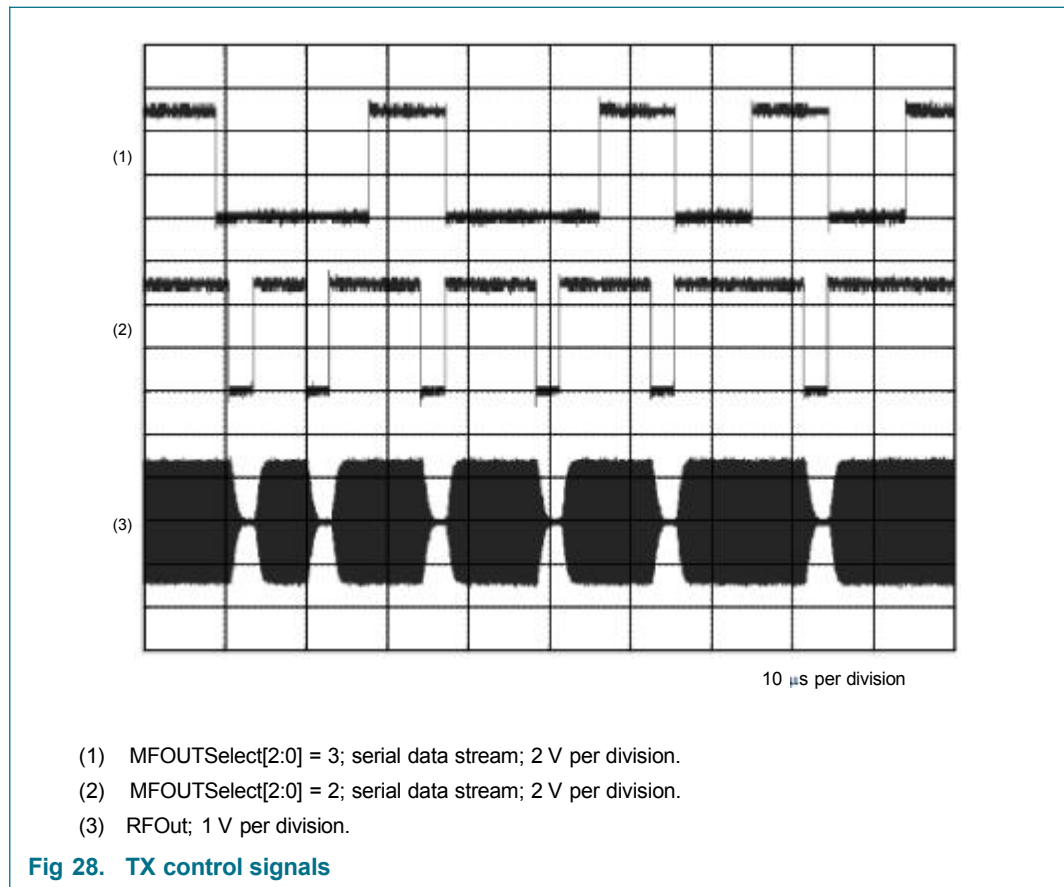

15.2.1.2 RX control

Figure 29 shows an example of ISO/IEC 14443 A communication which represents the beginning of a card's answer to a request signal.

The RF signal shows the RF voltage measured directly on the antenna so that the card's load modulation is visible. Setting MFOUTSelect[2:0] = 4 shows the Manchester decoded signal with subcarrier. Setting MFOUTSelect[2:0] = 5 shows the Manchester decoded signal.

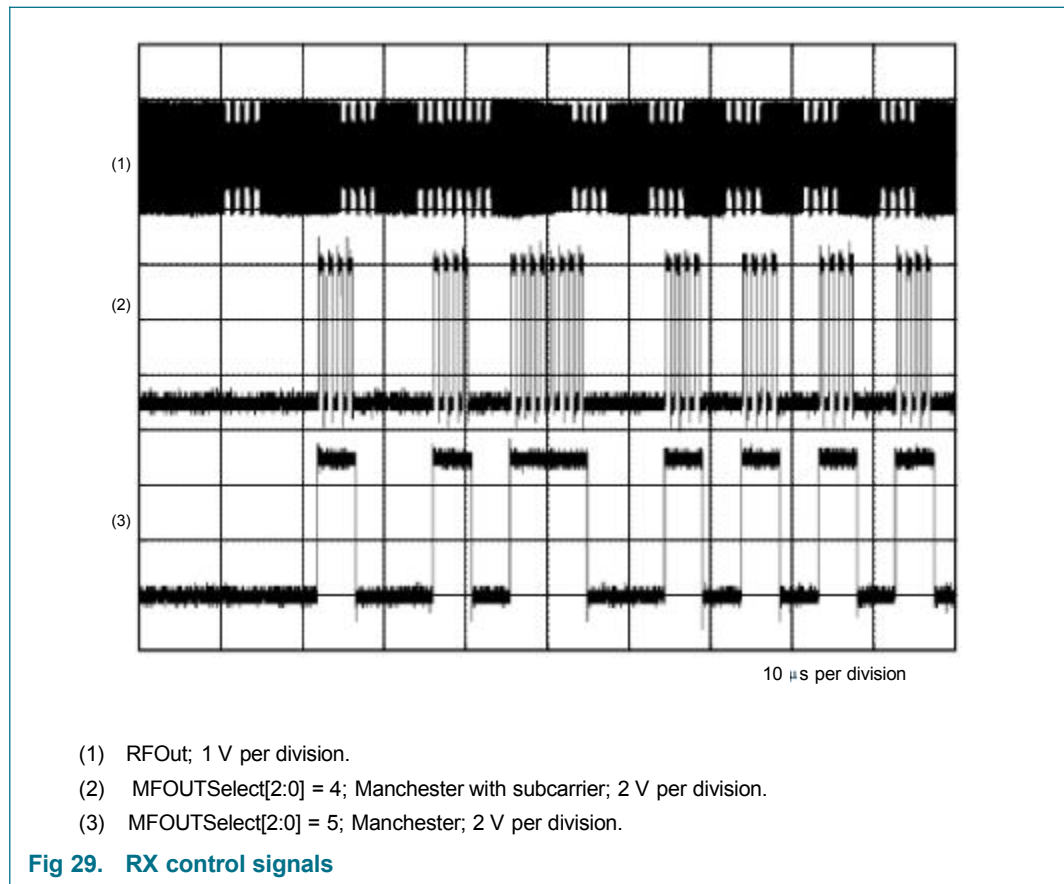

15.2.2 Analog test signals

The analog test signals can be routed to pin AUX by selecting them using the TestAnaSelect register TestAnaOutSel[4:0] bits.

Table 175. Analog test signal selection

Value	Signal Name	Description
0	VMID	voltage at internal node VMID
1	Vbandgap	internal reference voltage generated by the bandgap
2	VRxFoI1	output signal from the demodulator using the I-clock
3	VRxFoIQ	output signal from the demodulator using the Q-clock
4	VRxAmpI	I-channel subcarrier signal amplified and filtered
5	VRxAmpQ	Q-channel subcarrier signal amplified and filtered
6	VCorrNI	output signal of N-channel correlator fed by the I-channel subcarrier signal
7	VCorrNQ	output signal of N-channel correlator fed by the Q-channel subcarrier signal
8	VCorrDI	output signal of D-channel correlator fed by the I-channel subcarrier signal
9	VCorrDQ	output signal of D-channel correlator fed by the Q-channel subcarrier signal
A	VEvalL	evaluation signal from the left half-bit



Table 175. Analog test signal selection

Value	Signal Name	Description
B	VEvalR	evaluation signal from the right half-bit
C	VTemp	temperature voltage derived from band gap
D	reserved	reserved for future use
E	reserved	reserved for future use
F	reserved	reserved for future use

15.2.3 Digital test signals

Digital test signals can be routed to pin MFOUT by setting bit SignalToMFOUT = logic 1. A digital test signal is selected using the TestDigiSelect register TestDigiSignalSel[6:0] bits. The signals selected by the TestDigiSignalSel[6:0] bits are shown in Table 176.

Table 176. Digital test signal selection

TestDigiSignalSel [6:0]	Signal name	Description
F4h	s_data	data received from the card
E4h	s_valid	when logic 1 is returned the s_data and s_coll signals are valid
D4h	s_coll	when logic 1 is returned a collision has been detected in the current bit
C4h	s_clock	internal serial clock: during transmission, this is the encoder clock during reception this is the receiver clock
B5h	rd_sync	internal synchronized read signal which is derived from the parallel microprocessor interface
A5h	wr_sync	internal synchronized write signal which is derived from the parallel microprocessor interface
96h	int_clock	internal 13.56 MHz clock
83h	BPSK_out	BPSK output signal
E2h	BPSK_sig	BPSK signal's amplitude detected
00h	no test signal	output as defined by the MFOUTSelect register MFOUTSelect[2:0] bits routed to pin MFOUT

If test signals are not used, the TestDigiSelect register address value must be 00h.

Remark: All other values for TestDigiSignalSel[6:0] are for production test purposes only.

15.2.4 Examples of ISO/IEC 14443 A analog and digital test signals

Figure 30 shows a MIFARE card's answer to a request command using the Q-clock receiving path. RX reference is given to show the Manchester modulated signal on pin RX.

The signal is demodulated and amplified in the receiver circuitry. Signal VRXampQ is the amplified side-band signal using the Q-clock for demodulation. The signals VCorrDQ and VCorrNQ were generated in the correlation circuitry. They are processed further in the evaluation and digitizer circuitry.



Signals VEvalR and VEvalL show the evaluation of the signal's right and left half-bit. Finally, the digital test signal s_data shows the received data. This is then sent to the internal digital circuit and s_valid which indicates the received data stream is valid.

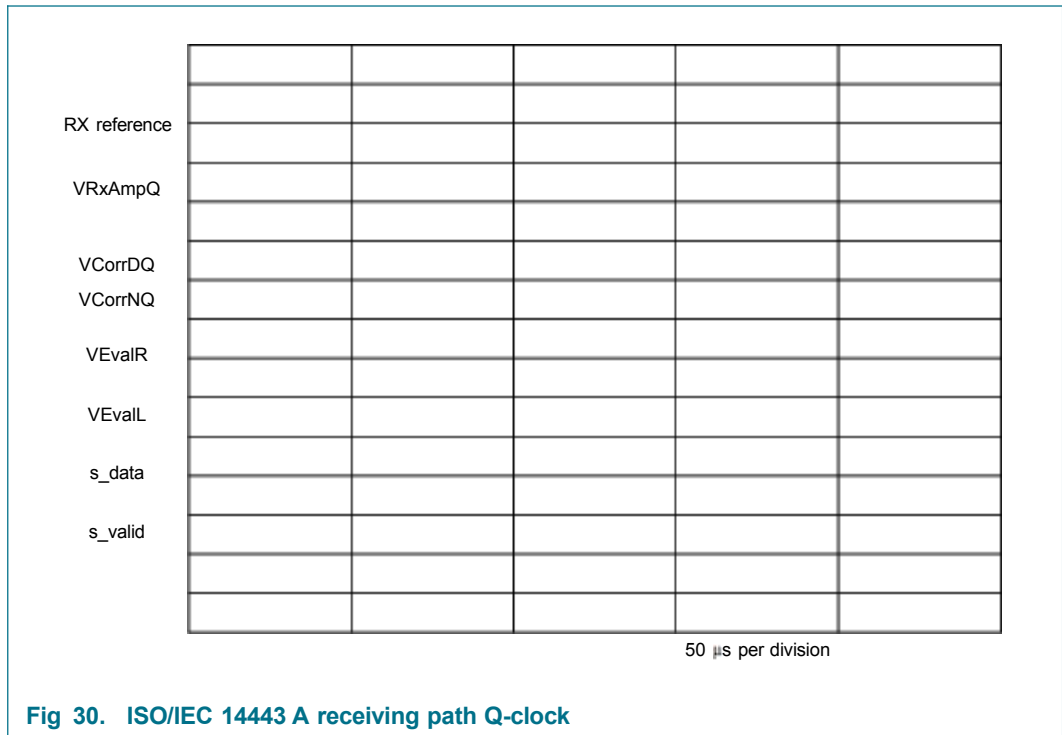

15.2.5 Examples of I-CODE1 analog and digital test signals

Figure 31 shows the answer of an I-CODE1 label IC to an unselected read command using the Q-clock receiving path. RX reference is given to show the Manchester modulated signal on pin RX.

The signal is demodulated and amplified in the receiver circuitry. Signal VRxAmpQ is the amplified side-band signal using the Q-clock for demodulation. The signals VCorrDQ and VCorrNQ generated in the correlation circuitry are processed further in the evaluation and digitizer circuitry.

Signals VEvalR and VEvalL are the evaluation signal of the right and left half-bit. Finally, the digital test-signal s_data shows the received data. This is then routed to the internal digital circuit and s_valid indicates that the received data stream is valid.

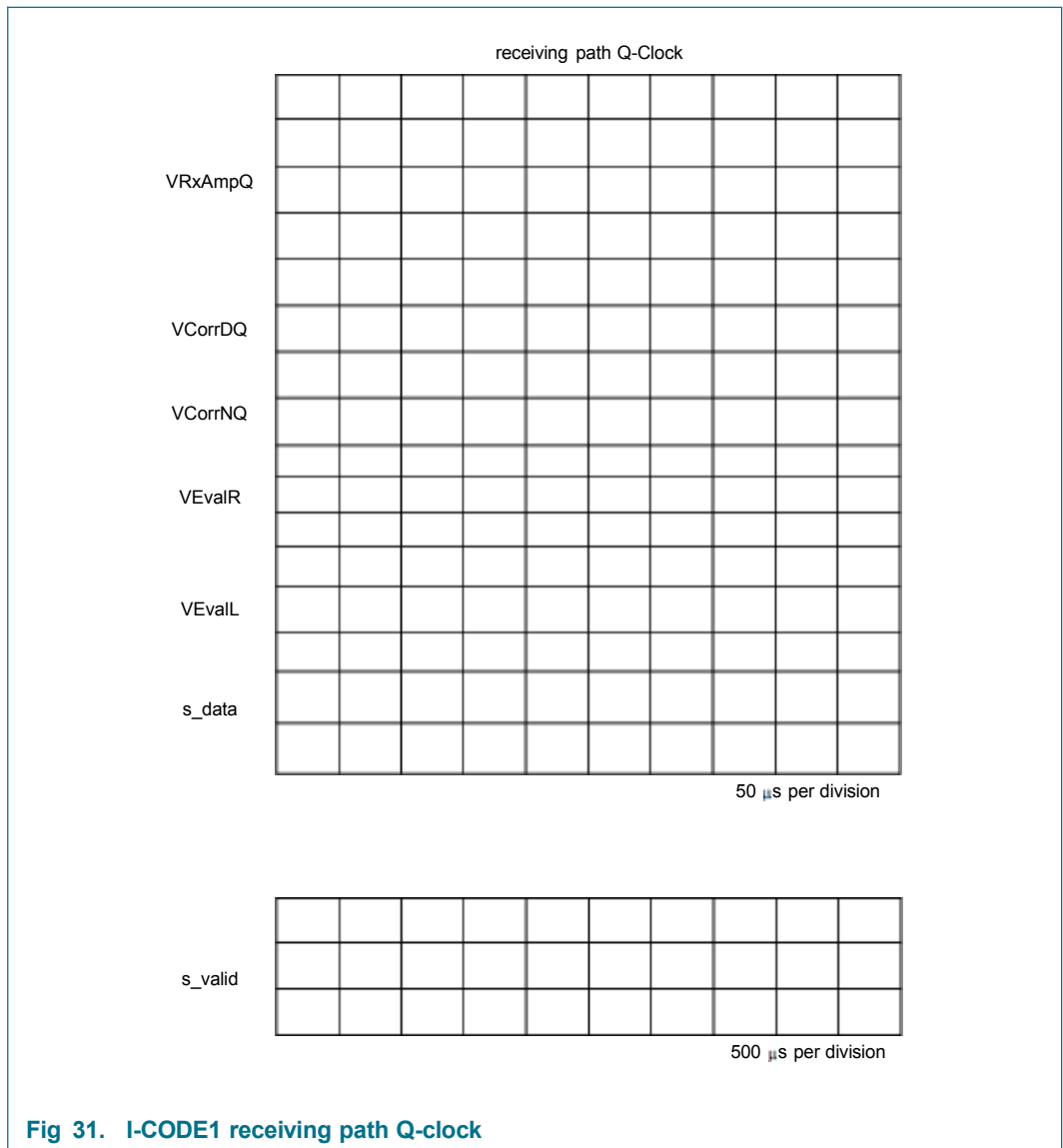

Fig 31. I-CODE1 receiving path Q-clock



16. Package outline

SO32: plastic small outline package; 32 leads; body width 7.5 mm

SOT287-1

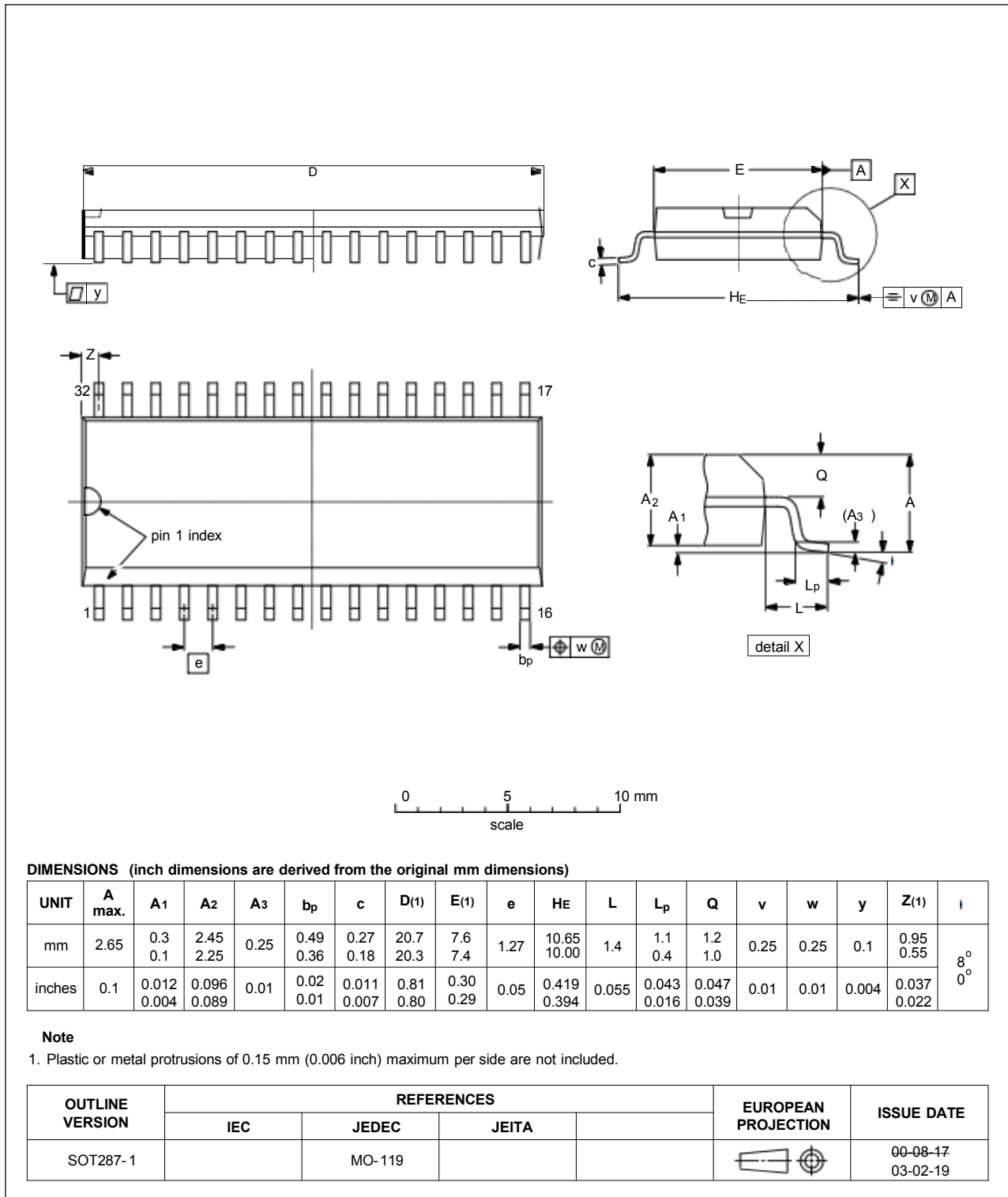

Fig 32. Package outline SOT287-1



17. Abbreviations

Table 177. Abbreviations and acronyms

Acronym	Description
ASK	Amplitude-Shift Keying
BPSK	Binary Phase-Shift Keying
CMOS	Complementary Metal-Oxide Semiconductor
CRC	Cyclic Redundancy Check
EOF	End Of Frame
EPP	Enhanced Parallel Port
ETU	Elementary Time Unit
FIFO	First In, First Out
HBM	Human Body Model
LSB	Least Significant Bit
MM	Machine Model
MSB	Most Significant Bit
NRZ	None Return to Zero
POR	Power-On Reset
PCD	Proximity Coupling Device
PICC	Proximity Integrated Circuit Card
SOF	Start Of Frame
SPI	Serial Peripheral Interface

18. References

- [1] **Application note** — MICORE reader IC family; Directly Matched Antenna Design.
- [2] **Application note** — MIFARE (14443 A) 13.56 MHz RFID Proximity Antennas.
- [3] **Application note** — Directly matched Antenna - Excel calculation.



19. Revision

Document ID	Release date	Data sheet status	Change notice	Supersedes
FSV9532	V1.0			



20. Tables

Table 1. Quick reference data	3	Table 44. Command register bit descriptions	50
Table 2. Ordering information	3	Table 45. FIFOData register (address: 02h) reset value: xxxx xxxxb, 05h bit allocation	51
Table 3. Pin description	5	Table 46. FIFOData register bit descriptions	51
Table 4. Supported microprocessor and EPP interface signals	7	Table 47. PrimaryStatus register (address: 03h) reset value: 0000 0101b, 05h bit allocation	51
Table 5. Connection scheme for detecting the parallel interface type	8	Table 48. PrimaryStatus register bit descriptions	51
Table 6. SPI compatibility	10	Table 49. FIFOLength register (address: 04h) reset value: 0000 0000b, 00h bit allocation	52
Table 7. SPI read data	10	Table 50. FIFOLength bit descriptions	52
Table 8. SPI read address	11	Table 51. SecondaryStatus register (address: 05h) reset value: 01100 000b, 60h bit allocation	53
Table 9. SPI write data	11	Table 52. SecondaryStatus register bit descriptions	53
Table 10. SPI write address	11	Table 53. InterruptEn register (address: 06h) reset value: 0000 0000b, 00h bit allocation	53
Table 11. EEPROM memory organization diagram	12	Table 54. InterruptEn register bit descriptions	53
Table 12. Product information field	13	Table 55. InterruptRq register (address: 07h) reset value: 0000 0000b, 00h bit allocation	54
Table 13. Product type identification definition	13	Table 56. InterruptRq register bit descriptions	54
Table 14. Byte assignment for register initialization at start-up	14	Table 57. Control register (address: 09h) reset value: 0000 0000b, 00h bit allocation	55
Table 15. Shipment content of StartUp configuration file	15	Table 58. Control register bit descriptions	55
Table 16. Byte assignment for register initialization at startup	16	Table 59. ErrorFlag register (address: 0Ah) reset value: 0100 0000b, 40h bit allocation	55
Table 17. Content of I-CODE1 startup configuration	17	Table 60. ErrorFlag register bit descriptions	55
Table 18. FIFO buffer access	19	Table 61. CollPos register (address: 0Bh) reset value: 0000 0000b, 00h bit allocation	56
Table 19. Associated FIFO buffer registers and flags	20	Table 62. CollPos register bit descriptions	56
Table 20. Interrupt sources	21	Table 63. TimerValue register (address: 0Ch) reset value: xxxx xxxxb, xxh bit allocation	57
Table 21. Interrupt control registers	21	Table 64. TimerValue register bit descriptions	57
Table 22. Associated Interrupt request system registers and flags	23	Table 65. CRCResultLSB register (address: 0Dh) reset value: xxxx xxxxb, xxh bit allocation	57
Table 23. TimeSlotPeriod	26	Table 66. CRCResultLSB register bit descriptions	57
Table 24. Associated timer unit registers and flags	27	Table 67. CRCResultMSB register (address: 0Eh) reset value: xxxx xxxxb, xxh bit allocation	57
Table 25. Signal on pins during Hard power-down	28	Table 68. CRCResultMSB register bit descriptions	57
Table 26. Pin TX1 configurations	31	Table 69. BitFraming register (address: 0Fh) reset value: 0000 0000b, 00h bit allocation	58
Table 27. Pin TX2 configurations	32	Table 70. BitFraming register bit descriptions	58
Table 28. TX1 and TX2 source resistance of n-channel driver transistor against GsCfgCW or GsCfgMod	33	Table 71. TxControl register (address: 11h) reset value: 0101 1000b, 58h bit allocation	59
Table 29. Gain factors for the internal amplifier	36	Table 72. TxControl register bit descriptions	59
Table 30. DecoderSource[1:0] values	39	Table 73. CwConductance register (address: 12h) reset value: 0011 1111b, 3Fh bit allocation	60
Table 31. ModulatorSource[1:0] values	39	Table 74. CwConductance register bit descriptions	60
Table 32. MFOUTSelect[2:0] values	39	Table 75. ModConductance register (address: 13h) reset value: 0011 1111b, 3Fh bit allocation	60
Table 33. Register settings to enable use of the analog circuitry	40	Table 76. ModConductance register bit descriptions	60
Table 34. MIFARE higher baud rates	40	Table 77. CoderControl register (address: 14h) reset value: 0001 1001b, 19h bit allocation	61
Table 35. ISO/IEC 14443 B registers and flags	41	Table 78. CoderControl register bit descriptions	61
Table 36. Dedicated address bus: assembling the register address	43	Table 79. ModWidth register (address: 15h) reset value: 0001 0011b, 13h bit allocation	62
Table 37. Multiplexed address bus: assembling the register address	44	Table 80. ModWidth register bit descriptions	62
Table 38. Behavior and designation of register bits	44	Table 81. ModWidthSOF register (address: 16h) reset	
Table 39. FSV9532 register overview	45		
Table 40. FSV9532 register flags overview	47		
Table 41. Page register (address: 00h, 08h, 10h, 18h, 20h, 28h, 30h, 38h) reset value: 1000 0000b, 80h bit allocation	50		
Table 42. Page register bit descriptions	50		
Table 43. Command register (address: 01h) reset value: x000 0000b, x0h bit allocation	50		



value: 0011 1111b, 3Fh bit allocation	62	Table 120. IRQPinConfig register (address: 2Dh) reset value: 0000 0010b, 02h bit allocation	73
Table 82. ModWidthSOF register bit descriptions	62	Table 121. IRQPinConfig register bit descriptions	73
Table 83. TypeBFraming register (address: 17h) reset value: 0011 1011b, 3Bh bit allocation	63	Table 122. PreSet2E register (address: 2Eh) reset value: xxxx xxxxb, xxh bit allocation	73
Table 84. TypeBFraming register bit descriptions	63	Table 123. PreSet2F register (address: 2Fh) reset value: xxxx xxxxb, xxh bit allocation	73
Table 85. RxControl1 register (address: 19h) reset value: 0111 0011b, 73h bit allocation	64	Table 124. Reserved registers (address: 31h, 32h, 33h, 34h, 35h, 36h, 37h) reset value: xxxx xxxxb, xxh bit allocation	73
Table 86. RxControl1 register bit descriptions	64	Table 125. Reserved register (address: 39h) reset value: xxxx xxxxb, xxh bit allocation	74
Table 87. DecoderControl register (address: 1Ah) reset value: 0000 1000b, 08h bit allocation	65	Table 126. TestAnaSelect register (address: 3Ah) reset value: 0000 0000b, 00h bit allocation	74
Table 88. DecoderControl register bit descriptions	65	Table 125. TestAnaSelect bit descriptions	74
Table 89. BitPhase register (address: 1Bh) reset value: 1010 1101b, ADh bit allocation	65	Table 128. Reserved register (address: 3Bh) reset value: xxxx xxxxb, xxh bit allocation	75
Table 90. BitPhase register bit descriptions	65	Table 129. Reserved register (address: 3Ch) reset value: xxxx xxxxb, xxh bit allocation	75
Table 91. RxThreshold register (address: 1Ch) reset value: 1111 1111b, FFh bit allocation	66	Table 130. TestDigiSelect register (address: 3Dh) reset value: xxxx xxxxb, xxh bit allocation	75
Table 92. RxThreshold register bit descriptions	66	Table 131. TestDigiSelect register bit descriptions	75
Table 93. BPSKDemControl register (address: 1Dh) reset value: 0001 1110b, 1Eh bit allocation	66	Table 132. Reserved register (address: 3Eh, 3Fh) reset value: xxxx xxxxb, xxh bit allocation	76
Table 94. BPSKDemControl register bit descriptions	66	Table 133. FSV9532 commands overview	76
Table 95. RxControl2 register (address: 1Eh) reset value: 0100 0001b, 41h bit allocation	67	Table 134. StartUp command 3Fh	78
Table 96. RxControl2 register bit descriptions	67	Table 135. Idle command 00h	78
Table 97. ClockQControl register (address: 1Fh) reset value: 00x xxxxb, xxh bit allocation	67	Table 136. Transmit command 1Ah	79
Table 98. ClockQControl register bit descriptions	67	Table 137. Transmission of frames of more than 64 bytes	82
Table 99. RxWait register (address: 21h) reset value: 0000 0101b, 06h bit allocation	68	Table 138. Receive command 16h	82
Table 100. RxWait register bit descriptions	68	Table 139. Return values for bit-collision positions	84
Table 101. ChannelRedundancy register (address: 22h) reset value: 0000 0011b, 03h bit allocation	68	Table 140. Communication error table	84
Table 102. ChannelRedundancy bit descriptions	68	Table 141. Transceive command 1Eh	85
Table 103. CRCPresetLSB register (address: 23h) reset value: 0101 0011b, 63h bit allocation	69	Table 142. Meaning of ModemState	85
Table 104. CRCPresetLSB register bit descriptions	69	Table 143. Transmit command 1Ah	87
Table 105. CRCPresetMSB register (address: 24h) reset value: 0101 0011b, 63h bit allocation	69	Table 144. Receive command 16h	88
Table 106. CRCPresetMSB bit descriptions	69	Table 145. Return values for bit-collision positions	90
Table 107. TimeSlotPeriod register (address: 25h) reset value: 0000 0000b, 00h bit allocation	69	Table 146. Communication error table	90
Table 108. TimeSlotPeriod register bit descriptions	70	Table 147. Transceive command 1Eh	91
Table 109. MFOUSelect register (address: 26h) reset value: 0000 0000b, 00h bit allocation	70	Table 148. ModemState values	91
Table 110. MFOUSelect register bit descriptions	70	Table 149. WriteE2 command 01h	93
Table 111. PreSet27 (address: 27h) reset value: xxxx xxxxb, xxh bit allocation	70	Table 150. ReadE2 command 03h	95
Table 112. FIFOLevel register (address: 29h) reset value: 0000 1000b, 08h bit allocation	71	Table 151. LoadConfig command 07h	95
Table 113. FIFOLevel register bit descriptions	71	Table 152. CalcCRC command 12h	96
Table 114. TimerClock register (address: 2Ah) reset value: 0000 0111b, 07h bit allocation	71	Table 153. CRC coprocessor parameters	96
Table 115. TimerClock register bit descriptions	71	Table 154. ErrorFlag register error flags overview	97
Table 116. TimerControl register (address: 2Bh) reset value: 0000 0110b, 06h bit allocation	72	Table 155. LoadKeyE2 command 0Bh	97
Table 117. TimerControl register bit descriptions	72	Table 156. LoadKey command 19h	97
Table 118. TimerReload register (address: 2Ch) reset value: 0000 1010b, 0Ah bit allocation	72	Table 157. Authent1 command 0Ch	98
Table 119. TimerReload register bit descriptions	72	Table 158. Authent2 command 14h	98
		Table 159. Limiting values	99
		Table 160. Operating condition range	99
		Table 161. Current consumption	100
		Table 162. Standard input pin characteristics	100
		Table 163. Schmitt trigger input pin characteristics	100
		Table 164. RSTPD input pin characteristics	101
		Table 165. RX input capacitance and input voltage	



range	101
Table 166. Digital output pin characteristics	101
Table 167. Antenna driver output pin characteristics	102
Table 168. Timing specification for separate read/write strobe	102
Table 169. Common read/write strobe timing specification	103
Table 170. Common read/write strobe timing specification for EPP	104
Table 171. SPI timing specification	106
Table 172. Clock frequency	106
Table 173. EEPROM characteristics	107
Table 174. Signal routed to pin MFOUT	110
Table 175. Analog test signal selection	112
Table 176. Digital test signal selection	113
Table 177. Abbreviations and acronyms	117



21. Figures

Fig 1.	FSV9532 block diagram	.4
Fig 2.	FSV9532 pin configuration	.5
Fig 3.	Connection to microprocessor: separate read and write strobes	.8
Fig 4.	Connection to microprocessor: common read and write strobes	.9
Fig 5.	Connection to microprocessor: EPP common read/write strobes and handshake.	.9
Fig 6.	Connection to microprocessor: SPI	.10
Fig 7.	Key storage format	.18
Fig 8.	Timer module block diagram	.24
Fig 9.	TimeSlotPeriod	.26
Fig 10.	The StartUp procedure.	.29
Fig 11.	Quartz clock connection	.30
Fig 12.	Receiver circuit block diagram	.35
Fig 13.	Automatic Q-clock calibration	.36
Fig 14.	Serial signal switch block diagram	.38
Fig 15.	Crypto1 key handling block diagram	.42
Fig 16.	Transmitting bit oriented frames	.80
Fig 17.	Timing for transmitting byte oriented frames	.81
Fig 18.	Timing for transmitting bit oriented frames	.81
Fig 19.	Card communication state diagram	.86
Fig 20.	Timing for transmitting byte oriented frames	.88
Fig 21.	Label communication state diagram	.92
Fig 22.	EEPROM programming timing diagram.	.94
Fig 23.	Separate read/write strobe timing diagram	.103
Fig 24.	Common read/write strobe timing diagram	.104
Fig 25.	Timing diagram for common read/write strobe; EPP	.105
Fig 26.	Timing diagram for SPI	.106
Fig 27.	Application example circuit diagram: directly matched antenna	.107
Fig 28.	TX control signals	.111
Fig 29.	RX control signals	.112
Fig 30.	ISO/IEC 14443 A receiving path Q-clock	.114
Fig 31.	I-CODE1 receiving path Q-clock	.115
Fig 32.	Package outline SOT287-1	.116



22. Contents

1	Introduction	1	9.4.3	Configuration of pin IRQ	22
2	General description	1	9.4.4	Register overview interrupt request system	23
3	Features and benefits	2	9.5	Timer unit	23
3.1	General	2	9.5.1	Timer unit implementation	24
4	Applications	2	9.5.1.1	Timer unit block diagram	24
5	Quick reference data	3	9.5.1.2	Controlling the timer unit	24
6	Ordering information	3	9.5.1.3	Timer unit clock and period	25
7	Block diagram	4	9.5.1.4	Timer unit status	25
8	Pinning information	5	9.5.1.5	TimeSlotPeriod	26
8.1	Pin description	5	9.5.2	Using the timer unit functions	27
9	Functional description	7	9.5.2.1	Time-out and WatchDog counters	27
9.1	Digital interface	7	9.5.2.2	Stopwatch	27
9.1.1	Overview of supported microprocessor interfaces	7	9.5.2.3	Programmable one shot timer and periodic trigger	27
9.1.2	Automatic microprocessor interface detection	7	9.5.3	Timer unit registers	27
9.1.3	Connection to different microprocessor types	8	9.6	Power reduction modes	28
9.1.3.1	Separate read and write strobe	8	9.6.1	Hard power-down	28
9.1.3.2	Common read and write strobe	9	9.6.2	Soft power-down mode	28
9.1.3.3	Common read and write strobe: EPP with handshake	9	9.6.3	Standby mode	29
9.1.4	Serial Peripheral Interface	9	9.6.4	Automatic receiver power-down	29
9.1.4.1	SPI read data	10	9.7	StartUp phase	29
9.1.4.2	SPI write data	11	9.7.1	Hard power-down phase	29
9.2	Memory organization of the EEPROM	12	9.7.2	Reset phase	29
9.2.1	Product information field (read only)	13	9.7.3	Initialization phase	30
9.2.2	Register initialization files (read/write)	13	9.7.4	Initializing the parallel interface type	30
9.2.2.1	StartUp register initialization file (read/write)	14	9.8	Oscillator circuit	30
9.2.2.2	Factory default StartUp register initialization file	14	9.9	Transmitter pins TX1 and TX2	31
9.2.2.3	Register initialization file (read/write)	16	9.9.1	Configuring pins TX1 and TX2	31
9.2.2.4	Content of I-CODE1 and ISO/IEC 15693 StartUp register values	16	9.9.2	Antenna operating distance versus power consumption	32
9.2.3	Crypto1 keys (write only)	18	9.9.3	Antenna driver output source resistance	32
9.2.3.1	Key format	18	9.9.3.1	Source resistance table	33
9.2.3.2	Storage of keys in the EEPROM	18	9.9.3.2	Calculating the relative source resistance	34
9.3	FIFO buffer	19	9.9.3.3	Calculating the effective source resistance	34
9.3.1	Accessing the FIFO buffer	19	9.9.4	Pulse width	34
9.3.1.1	Access rules	19	9.10	Receiver circuitry	34
9.3.2	Controlling the FIFO buffer	19	9.10.1	Receiver circuit block diagram	35
9.3.3	FIFO buffer status information	20	9.10.2	Receiver operation	35
9.3.4	FIFO buffer registers and flags	20	9.10.2.1	Automatic Q-clock calibration	35
9.4	Interrupt request system	20	9.10.2.2	Amplifier	36
9.4.1	Interrupt sources overview	21	9.10.2.3	Correlation circuitry	37
9.4.2	Interrupt request handling	21	9.10.2.4	Evaluation and digitizer circuitry	37
9.4.2.1	Controlling interrupts and getting their status	21	9.11	Serial signal switch	37
9.4.2.2	Accessing the interrupt registers	22	9.11.1	Serial signal switch block diagram	38
			9.11.2	Serial signal switch registers	38
			9.11.2.1	Active antenna concept	39
			9.11.2.2	Driving both RF parts	40
			9.12	MIFARE higher baud rates	40



9.13	ISO/IEC 14443 B communication scheme	41	10.5.5.1	Page register	68
9.14	MIFARE authentication and Crypto1	42	10.5.5.2	RxWait register.	68
9.14.1	Crypto1 key handling	42	10.5.5.3	ChannelRedundancy register	68
9.14.2	Authentication procedure	43	10.5.5.4	CRCPresetLSB register	69
10	FSV9532 registers.	43	10.5.5.5	CRCPresetMSB register	69
10.1	Register addressing modes	43	10.5.5.6	TimeSlotPeriod register	69
10.1.1	Page registers	43	10.5.5.7	MFOUTSelect register	70
10.1.2	Dedicated address bus	43	10.5.5.8	PreSet27 register	70
10.1.3	Multiplexed address bus	43	10.5.6	Page 5: FIFO, timer and IRQ pin configuration	71
10.2	Register bit behavior.	44	10.5.6.1	Page register	71
10.3	Register overview	45	10.5.6.2	FIFOLevel register	71
10.4	FSV9532 register flags overview	47	10.5.6.3	TimerClock register	71
10.5	Register descriptions	50	10.5.6.4	TimerControl register	72
10.5.1	Page 0: Command and status	50	10.5.6.5	TimerReload register	72
10.5.1.1	Page register	50	10.5.6.6	IRQPinConfig register	73
10.5.1.2	Command register	50	10.5.6.7	PreSet2E register.	73
10.5.1.3	FIFOData register	51	10.5.6.8	PreSet2F register.	73
10.5.1.4	PrimaryStatus register	51	10.5.7	Page 6: reserved	73
10.5.1.5	FIFOLength register	52	10.5.7.1	Page register	73
10.5.1.6	SecondaryStatus register	53	10.5.7.2	Reserved registers 31h, 32h, 33h, 34h, 35h, 36h and 37h	73
10.5.1.7	InterruptEn register.	53	10.5.8	Page 7: Test control	74
10.5.1.8	InterruptRq register.	54	10.5.8.1	Page register	74
10.5.2	Page 1: Control and status	55	10.5.8.2	Reserved register 39h	74
10.5.2.1	Page register	55	10.5.8.3	TestAnaSelect register	74
10.5.2.2	Control register	55	10.5.8.4	Reserved register 3Bh	75
10.5.2.3	ErrorFlag register	55	10.5.8.5	Reserved register 3Ch	75
10.5.2.4	CollPos register	56	10.5.8.6	TestDigiSelect register	75
10.5.2.5	TimerValue register.	57	10.5.8.7	Reserved registers 3Eh, 3Fh	76
10.5.2.6	CRCResultLSB register	57	11	FSV9532 command set	76
10.5.2.7	CRCResultMSB register.	57	11.1	FSV9532 command overview	76
10.5.2.8	BitFraming register	58	11.1.1	Basic states	78
10.5.3	Page 2: Transmitter and control	59	11.1.2	StartUp command 3Fh	78
10.5.3.1	Page register	59	11.1.3	Idle command 00h	78
10.5.3.2	TxControl register	59	11.2	Commands for ISO/IEC 14443 A card communication	79
10.5.3.3	CwConductance register	60	11.2.1	Transmit command 1Ah	79
10.5.3.4	ModConductance register.	60	11.2.1.1	Using the Transmit command	79
10.5.3.5	CoderControl register	61	11.2.1.2	RF channel redundancy and framing	80
10.5.3.6	ModWidth register.	62	11.2.1.3	Transmission of bit oriented frames	80
10.5.3.7	ModWidthSOF register	62	11.2.1.4	Transmission of frames with more than 64 bytes	80
10.5.3.8	TypeBFraming	63	11.2.2	Receive command 16h	82
10.5.4	Page 3: Receiver and decoder control	64	11.2.2.1	Using the Receive command	82
10.5.4.1	Page register	64	11.2.2.2	RF channel redundancy and framing	82
10.5.4.2	RxControl1 register.	64	11.2.2.3	Collision detection	83
10.5.4.3	DecoderControl register	65	11.2.2.4	Receiving bit oriented frames	84
10.5.4.4	BitPhase register	65	11.2.2.5	Communication errors	84
10.5.4.5	RxThreshold register	66	11.2.3	Transceive command 1Eh	85
10.5.4.6	BPSKDemControl	66			
10.5.4.7	RxControl2 register.	67			
10.5.4.8	ClockQControl register	67			
10.5.5	Page 4: RF Timing and channel redundancy	68			



FSV9532

Standard multi-protocol reader solution

11.2.4	States of the card communication	85	13.4.2	Common read/write strobe bus timing	103
11.2.5	Card communication state diagram	86	13.4.3	EPP bus timing	104
11.3	I-CODE1 and ISO/IEC 15693 label communication commands	87	13.4.4	SPI timing	106
11.3.1	Transmit command 1Ah	87	13.4.5	Clock frequency	106
11.3.1.1	Using the Transmit command	87	14	EEPROM characteristics	107
11.3.1.2	RF channel redundancy and framing	88	15	Application information	107
11.3.1.3	Transmission of frames of more than 64 bytes	88	15.1	Typical application	107
11.3.2	Receive command 16h	88	15.1.1	Circuit diagram	107
11.3.2.1	Using the Receive command	89	15.1.2	Circuit description	108
11.3.2.2	RF channel redundancy and framing	89	15.1.2.1	EMC low-pass filter	108
11.3.2.3	Collision detection	89	15.1.2.2	Antenna matching	108
11.3.2.4	Communication errors	90	15.1.2.3	Receiver circuit	108
11.3.3	Transceive command 1Eh	91	15.2.1	Antenna coil	109
11.3.4	Label communication states	91		Test signals	110
11.3.5	Label communication state diagram	92	15.2.1.1	Measurements using the serial signal switch	110
11.4	EEPROM commands	93	15.2.1.2	TX control	110
11.4.1	WriteE2 command 01h	93	15.2.3	RX control	111
11.4.1.1	Programming process	93	15.2.4	Analog test signals	112
11.4.1.2	Timing diagram	94		Digital test signals	113
11.4.1.3	WriteE2 command error flags	94	15.2.5	Examples of ISO/IEC 14443 A analog and digital test signals	113
11.4.2	ReadE2 command 03h	95		Examples of I-CODE1 analog and digital test signals	114
11.4.2.1	ReadE2 command error flags	95	16	Package outline	116
11.5	Diverse commands	95			
11.5.1	LoadConfig command 07h	95			
11.5.1.1	Register assignment	95			
11.5.1.2	Relevant LoadConfig command error flags	96			
11.5.2	CalcCRC command 12h	96			
11.5.2.1	CRC coprocessor settings	96			
11.5.2.2	CRC coprocessor status flags	96			
11.6	Error handling during command execution	97			
11.7	MIFARE security commands	97			
11.7.1	LoadKeyE2 command 0Bh	97			
11.7.1.1	Relevant LoadKeyE2 command error flags	97			
11.7.2	LoadKey command 19h	97			
11.7.2.1	Relevant LoadKey command error flags	98			
11.7.3	Authent1 command 0Ch	98			
11.7.4	Authent2 command 14h	98			
11.7.4.1	Authent2 command effects	99			
12	Limiting values	99			
13	Characteristics	99			
13.1	Operating condition range	99			
13.2	Current consumption	100			
13.3	Pin characteristics	100			
13.3.1	Input pin characteristics	100			
13.3.2	Digital output pin characteristics	101			
13.3.3	Antenna driver output pin characteristics	101			
13.4	AC electrical characteristics	102			
13.4.1	Separate read/write strobe bus timing	102			