

MAPX	MODIFICATION	DATE
------	--------------	------

NOTES:
 1. HOUSING: SEE NOTES, UJ94V-0.
 TERMINAL: SEE NOTES.
 SHELL: SEE NOTES.

SPECIFICATION:
 1. ELECTRICAL CHARACTERISTIC:
 CONTACT RESISTANCE: 30MΩ MAX
 DIELECTRIC WITHSTANDING VOLTAGE: 500V AC FOR 1MIN
 INSULATION RESISTANCE: 1000MΩ MIN
 2. MECHANICAL CHARACTERISTIC:
 INSERTION FORCE: 35N(3.57KGF) MAX
 EXTRACTON FORCE: 10~35N(1.02~3.57KGF)MIN
 DURABILITY: 1500 CYCLES EXTRACTON FORCE: 10~35N
 5000 CYCLES MIN
 5000 CYCLES EXTRACTON FORCE: 3~35N

3. ENVIRONMENTAL:
 OPERATING TEMPERATURE: -55°C+85°C
 4. Contact finish:
 01: Selective Gold Flash
 02: Selective Gold 3U"
 03: Selective Gold 5U"
 04: Selective Gold 15U"
 05: Selective Gold 30U"

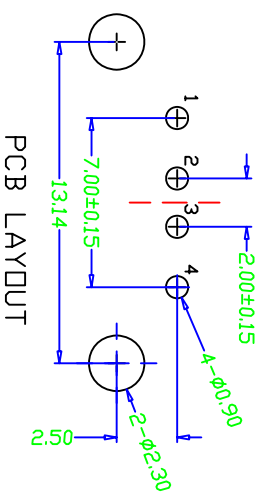
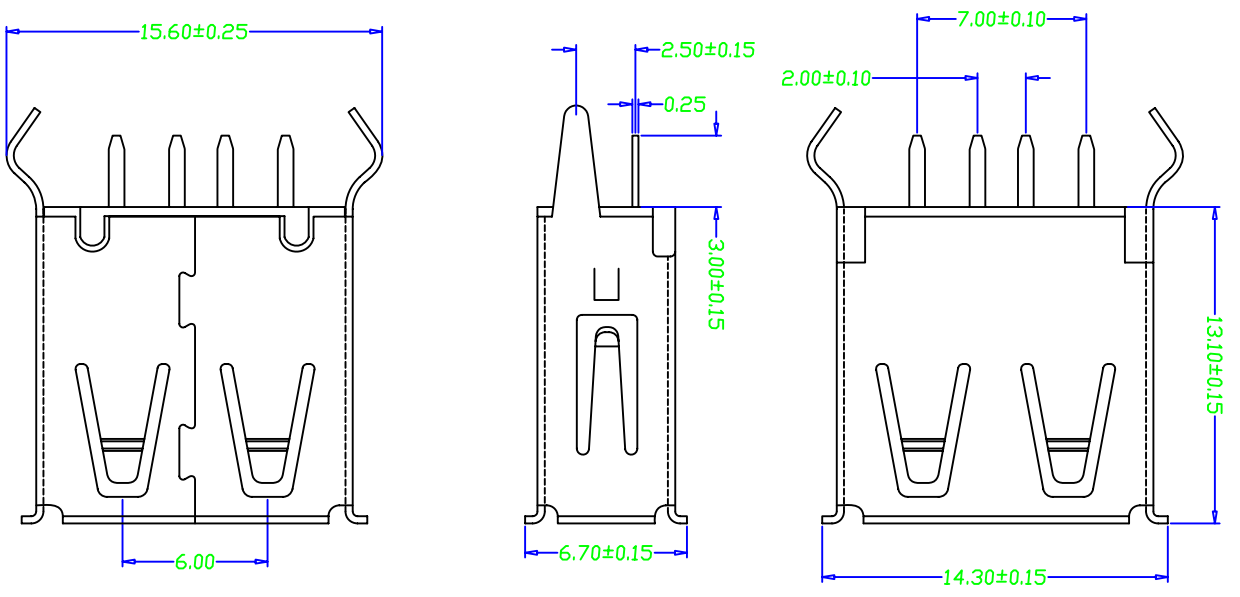

产品图
PRODUCT CHART DWG

深圳市精拓金电子有限公司

公差一览表		单位		制图		制料号	
TOLERANCE UNLESS OTHERWISE	UNITS	MM	Z-Y-B	DRAWING	2-Y-B	PRODUCT PART NO.	916-152A1012Y10200
X. ±0.25	X.	±5°	比例	审核	郭治富	产品名称	4F13.1弯脚180度有边铜壳PBT白胶
X. ±0.20	X.	±2°	SCALE	CHKD		Product NO.	
XX. ±0.15	XX.	±1°	日期	核准	黄国荣	角法	
XXX. ±0.10	XXX.	±0.5°	DATE	APRD		VER	版本
							AD

1 2 3 4 5 6 7 8 9 10

G F E D C B A

G F E D C B A