

Technical Data Sheet

Top View LEDs

45-21UNC/3335475/TR8

Features

- Top View White LEDs
- Lead frame package with individual 2 pins
- Wide viewing angle
- Soldering methods: IR reflow soldering
- Pb-free
- The product itself will remain within RoHS compliant version.



Descriptions

- Due to the package design, 45-21 has wide viewing angle, low power consumption and white LEDs are devices which are materialized by combing blue chips and special phosphor. This feature makes the LED ideal for light guide application.

Applications

- LCD back light
- Mobile phones
- Indicators
- Illuminations
- Switch Lights

Device Selection Guide

Chip	Emitted Color	Resin Color
Material		
InGaN	White	Water Clear

Technical Data Sheet

Top View LEDs

45-21UNC/3335475/TR8

Package Outline Dimensions

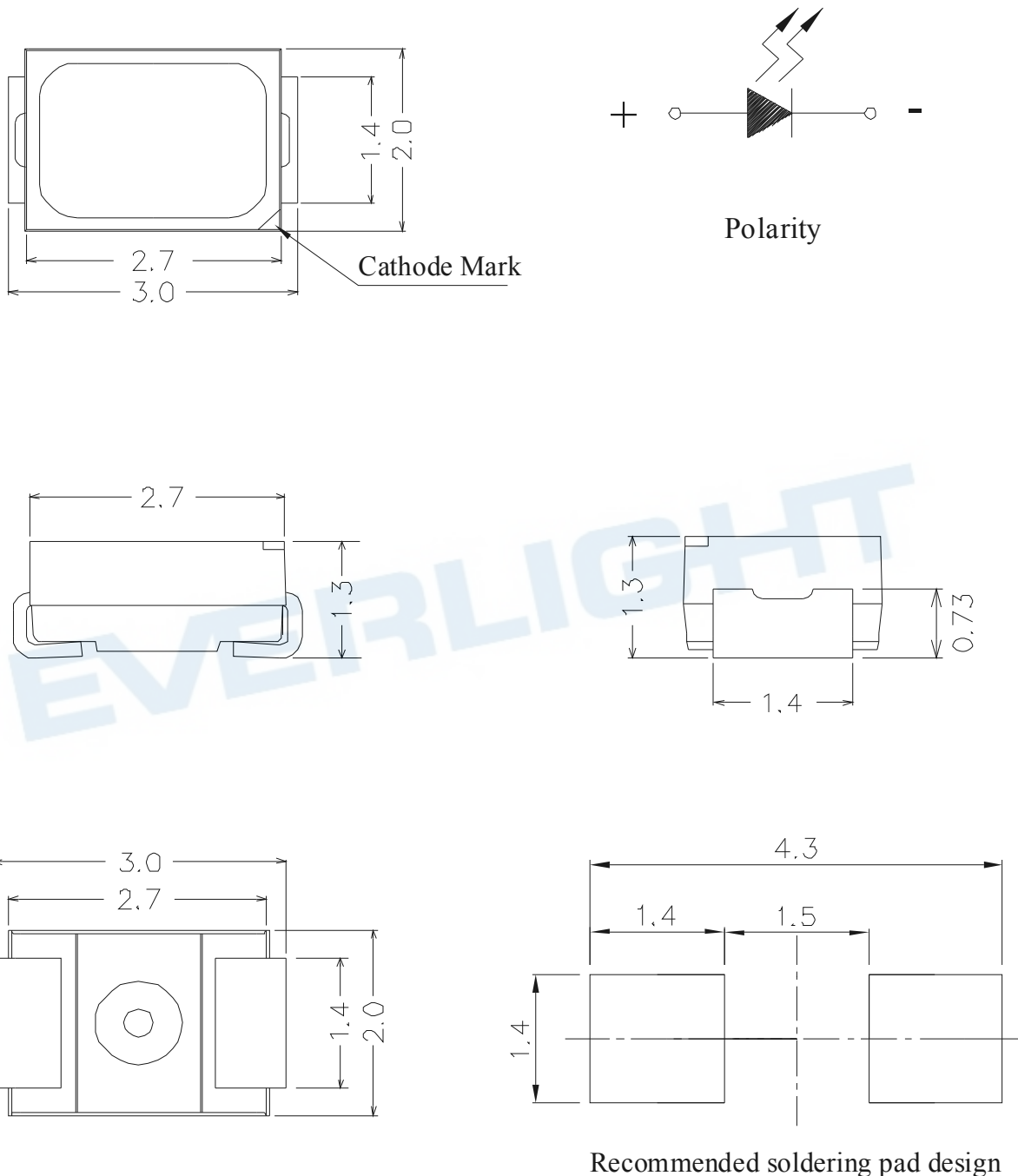

Note: Tolerances unless dimension are ± 0.1 mm, unit = mm.

Technical Data Sheet

Top View LEDs

45-21UNC/3335475/TR8

Absolute Maximum Ratings (Ta=25°C)

Parameter	Symbol	Rating	Unit
Reverse Voltage	V _R	5	V
Forward Current	I _F	30	mA
Peak Forward Current (Duty 1/10 @1KHz)	I _{FP}	100	mA
Power Dissipation	P _d	110	mW
Electrostatic Discharge(HBM)* ¹	ESD	1000	V
Operating Temperature	Topr	-40 ~ +85	°C
Storage Temperature	Tstg	-40 ~ +90	°C
Soldering Temperature	Tsol	Reflow Soldering: 260 °C for 10 sec. Hand Soldering: 350 °C for 3 sec.	

Note: The products are sensitive to static electricity and must be carefully taken when handling products.

Electro-Optical Characteristics (Ta=25°C)

Parameter	Symbol	Min.	Typ.	Max.	Unit	Condition
Luminous Intensity	I _V	1750	---	1900	mcd	I _F =20mA
Viewing Angle	2θ _{1/2}	---	120	---	deg	I _F =20mA
Forward Voltage	V _F	2.9	---	3.4	V	I _F =20mA
Reverse Current	I _R	---	---	50	μA	V _R =5V

Notes:

1. Tolerance of Luminous Intensity: ±11%
2. Tolerance of Forward Voltage: ± 0.05V

Technical Data Sheet

Top View LEDs

45-21UNC/3335475/TR8

Bin Range of Luminous Intensity

Bin Code	Min.	Max.	Unit	Condition
33	1750	1800	mcd	I _F =20mA
34	1800	1850		
35	1850	1900		

Note: Tolerance of Luminous Intensity: $\pm 11\%$

Bin Range of Forward Voltage

Group	Bin Code	Min.	Max.	Unit	Condition
E	5-2-3	2.9	3.0	V	I _F =20mA
	6-1-3	3.0	3.1		
	6-2-3	3.1	3.2		
	7-1-3	3.2	3.3		
	7-2-3	3.3	3.4		

Note: Tolerance of Forward Voltage: $\pm 0.05V$

Technical Data Sheet

Top View LEDs

45-21UNC/3335475/TR8

Bin Range of Chromaticity Coordinates

Group	Bin Code	CIE_x	CIE_y	Bin Code	CIE_x	CIE_y
47	B6-1	0.309	0.3045	B6-2	0.3195	0.3165
		0.307	0.315		0.3185	0.327
		0.3185	0.327		0.33	0.339
		0.3195	0.3165		0.33	0.3285
	B6-3	0.311	0.294	B6-4	0.3205	0.306
		0.309	0.3045		0.3195	0.3165
		0.3195	0.3165		0.33	0.3285
		0.3205	0.306		0.33	0.318

Note: Tolerance of Chromaticity Coordinates: ± 0.01

Technical Data Sheet

Top View LEDs

45-21UNC/3335475/TR8

The C.I.E. 1931 Chromaticity Diagram

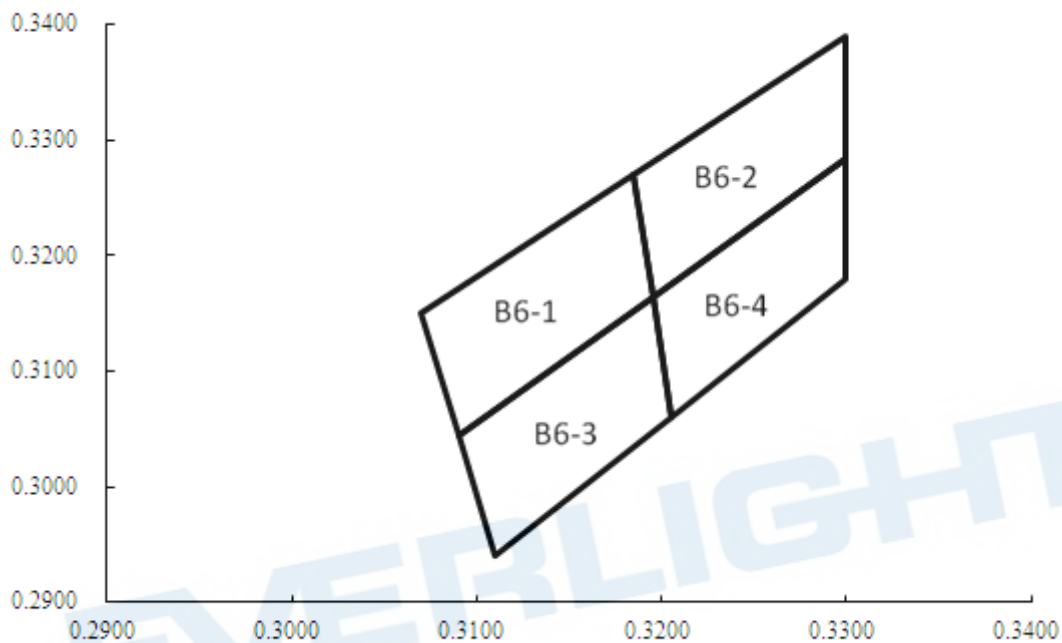

Technical Data Sheet

Top View LEDs

45-21UNC/3335475/TR8

Typical Electro-Optical Characteristics Curves

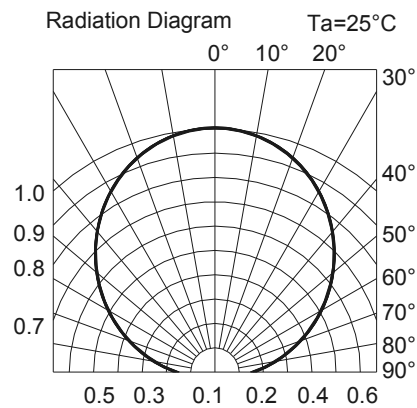
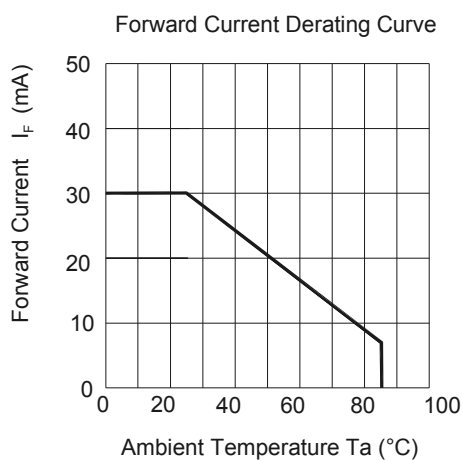
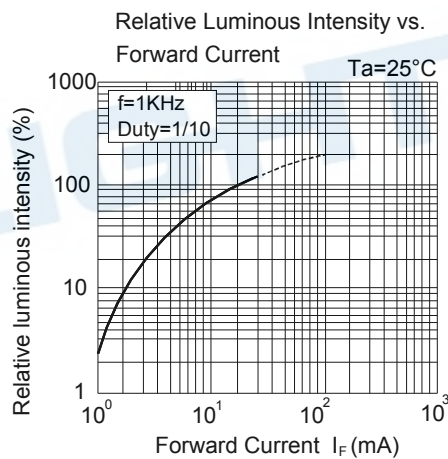
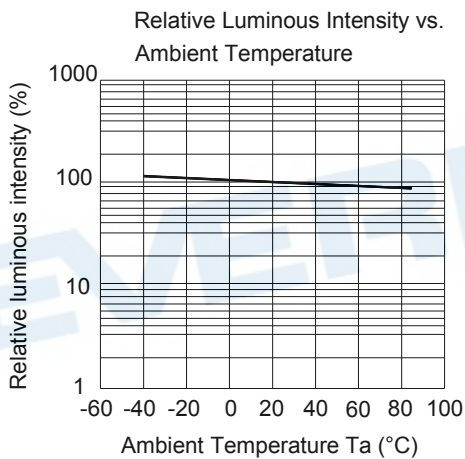
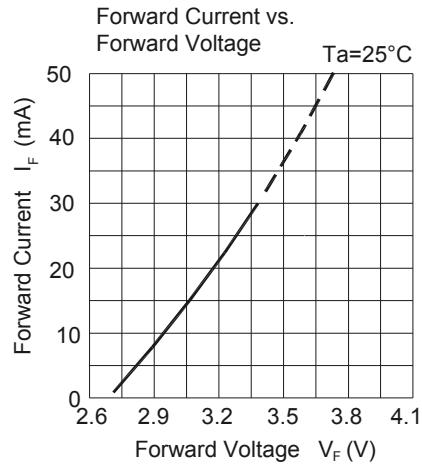
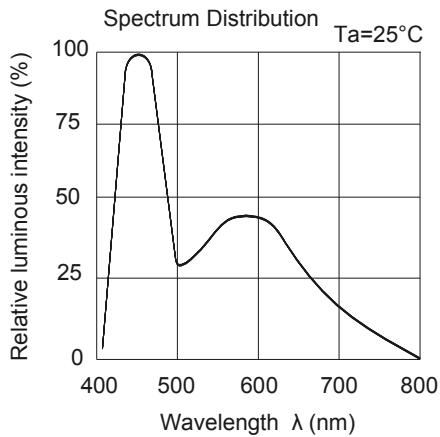

Technical Data Sheet

Top View LEDs

45-21UNC/3335475/TR8

Label Explanation

CAT: Luminous Intensity Rank

HUE: Chromaticity Coordinates

REF: Forward Voltage Rank



Reel Dimensions

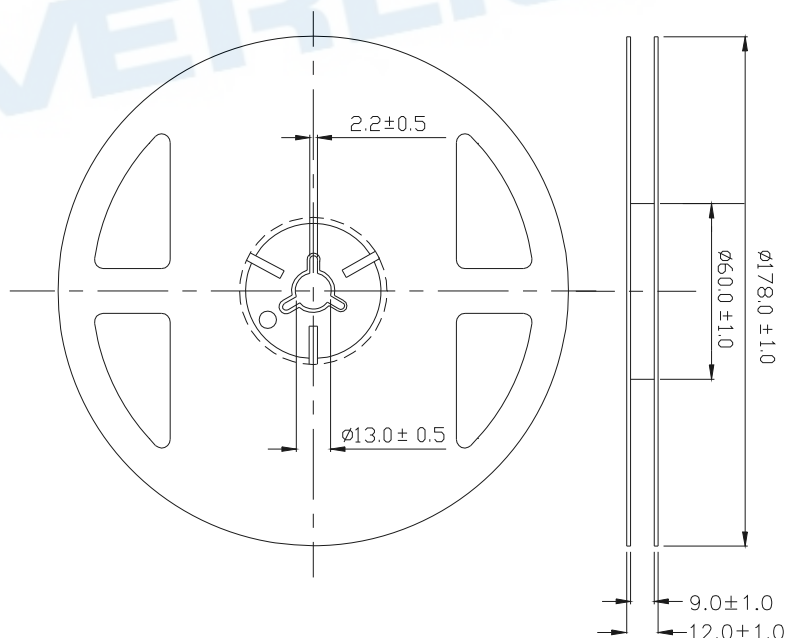

Note: The tolerances unless mentioned are ± 0.1 mm, unit = mm.

Technical Data Sheet

Top View LEDs

45-21UNC/3335475/TR8

Carrier Tape Dimensions: Loaded Quantity 2000 pcs. Per Reel

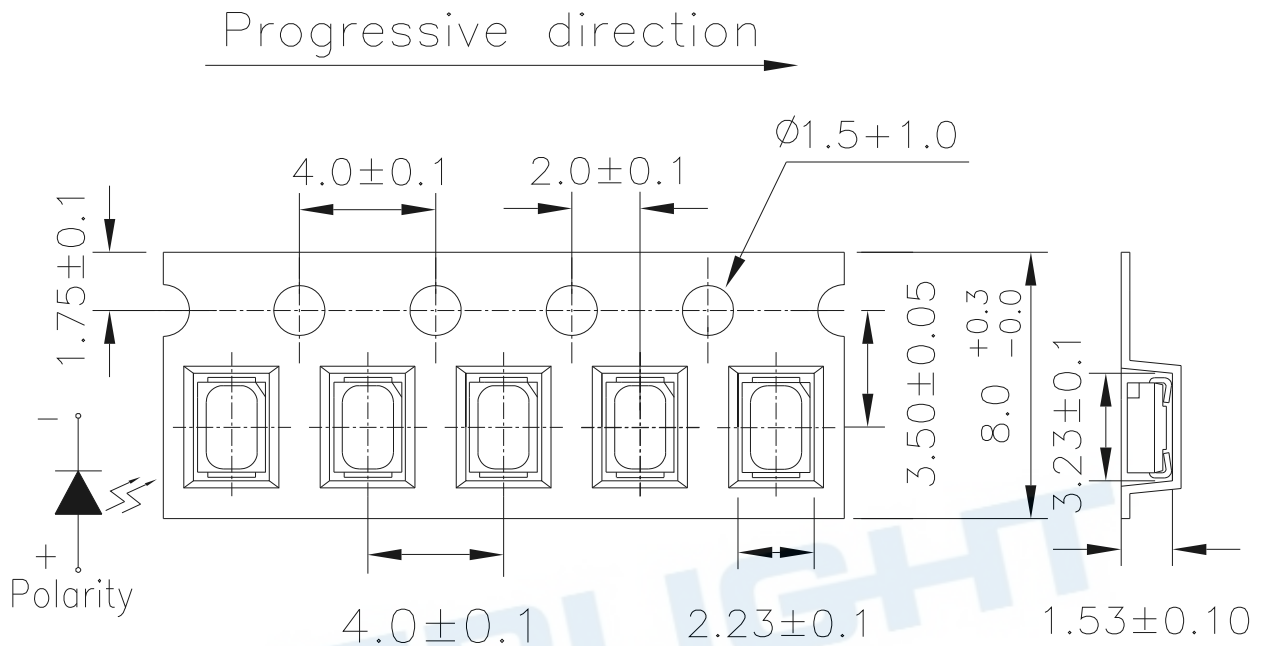

Note: Tolerances unless dimension are ±0.1mm, unit = mm.

Moisture Resistant Packaging

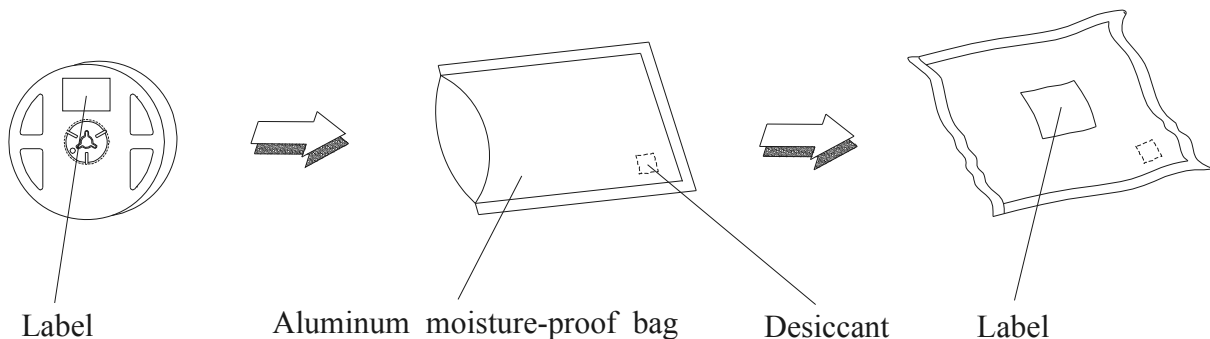

Technical Data Sheet

Top View LEDs

45-21UNC/3335475/TR8

Reliability Test Items and Conditions

The reliability of products shall be satisfied with items listed below.

Confidence level : 90%

LTPD : 10%

No.	Items	Test Condition	Test Hours/Cycles	Sample Size	Ac/Re
1	Reflow Soldering	Temp. : 260°C±5°C Min. 10 sec.	6 Min.	22 PCS.	0/1
2	Temperature Cycle	H : +100°C 15min ┆ 5 min L : -40°C 15min	300 Cycles	22 PCS.	0/1
3	Thermal Shock	H : +100°C 5min ┆ 10 sec L : -10°C 5min	300 Cycles	22 PCS.	0/1
4	High Temperature Storage	Temp. : 100°C	1000 Hrs.	22 PCS.	0/1
5	Low Temperature Storage	Temp. : -40°C	1000 Hrs.	22 PCS.	0/1
6	DC Operating Life	I _F = 20 mA / 25°C	1000 Hrs.	22 PCS.	0/1
7	High Temperature / High Humidity	85°C/85%RH	1000 Hrs.	22 PCS.	0/1

Technical Data Sheet

Top View LEDs

45-21UNC/3335475/TR8

Precautions for Use

1. Over-current-proof

Customer must apply resistors for protection, otherwise slight voltage shift will cause big current change (Burn out will happen).

2. Storage

2.1 Do not open moisture proof bag before the products are ready to use.

2.2 Before opening the package: The LEDs should be used within one year and kept at 30°C or less and 70%RH or less.

2.3 After opening the package: We recommend that the LED should be soldered quickly (within 3 days).The soldering condition is 30°C or less and 60% RH or less. If unused LEDs remain, it should be stored in moisture proof packages.

2.4 If the moisture absorbent material (silica gel) has faded away or the LEDs have exceeded the storage time, baking treatment should be performed using the following conditions.

Baking treatment: 60±5°C for 24 hours.(One time only)

3. Soldering Condition

3.1 Pb-free solder temperature profile

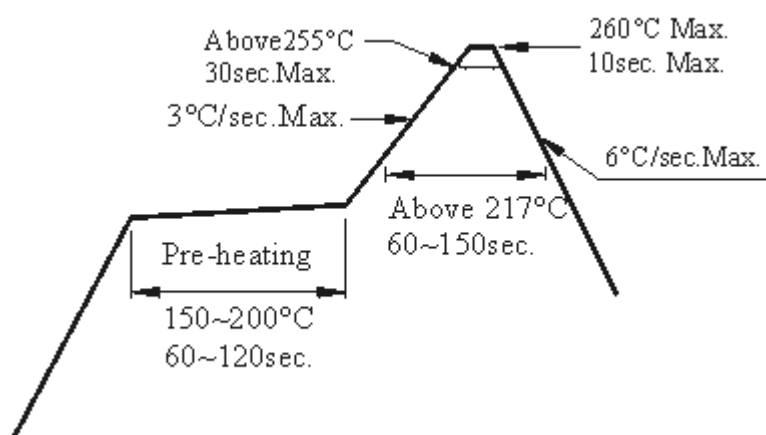

3.2 Reflow soldering should not be done more than two times.

3.3 When soldering, do not put stress on the LEDs during heating.

3.4 After soldering, do not warp the circuit board.

Technical Data Sheet

Top View LEDs

45-21UNC/3335475/TR8

4. Soldering Iron

Each terminal is to go to the tip of soldering iron temperature less than 350°C for 3 seconds within once in less than the soldering iron capacity 25W. Leave two seconds and more intervals, and do soldering of each terminal. Be careful because the damage of the product is often started at the time of the hand solder.

5. Repairing

Repair should not be done after the LEDs have been soldered. When repairing is unavoidable, a double-head soldering iron should be used (as below figure). It should be confirmed beforehand whether the characteristics of the LEDs will or will not be damaged by repairing.

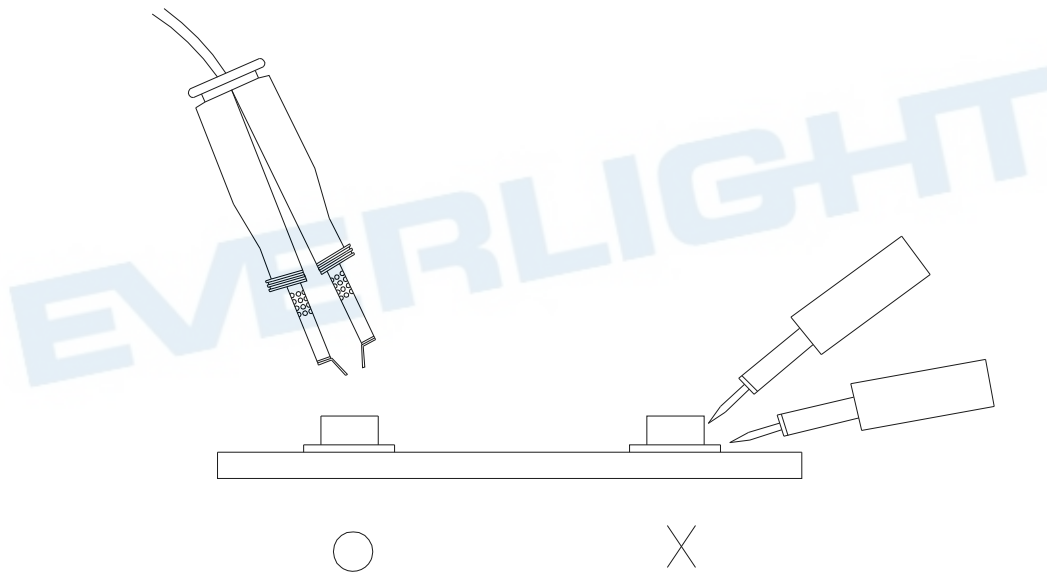

EVERLIGHT ELECTRONICS CO., LTD.
Office: No 25, Lane 76, Sec 3, Chung Yang Rd,
Tucheng, Taipei 236, Taiwan, R.O.C

Tel: 886-2-2267-2000, 2267-9936
Fax: 886-2267-6244, 2267-6189, 2267-6306
<http://www.everlight.com>