

目錄 MAPX	變更內容 MODIFICATION	日期 DATE
------------	----------------------	------------

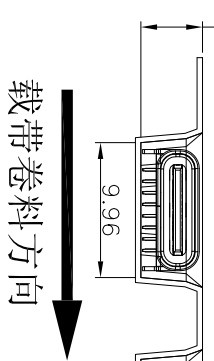

NOTES

- 1. 帶子引導長度
LEAD TAPE LENGTH
出料方向
PULL OUT DIRECTION

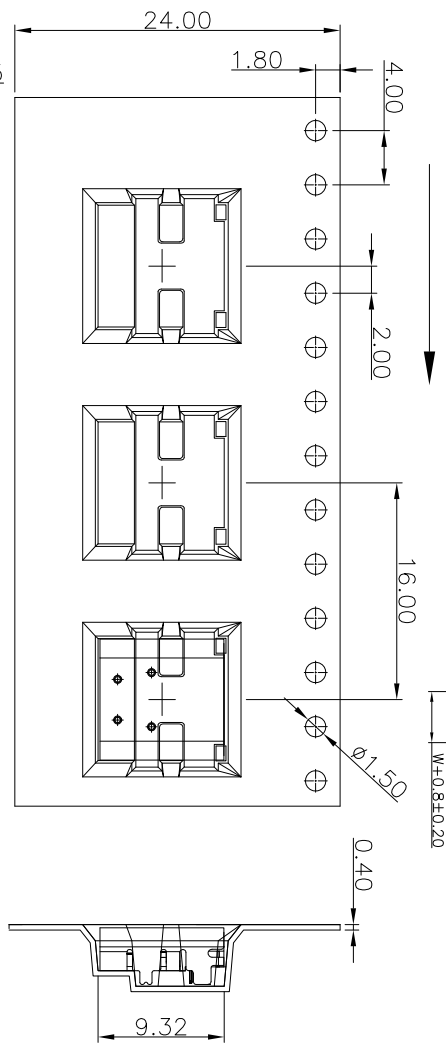
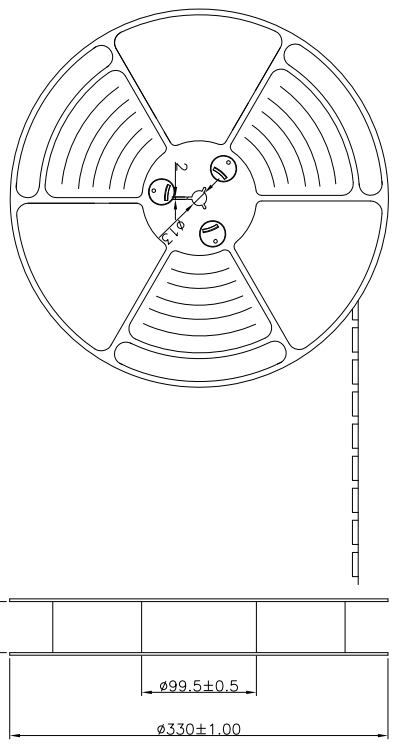
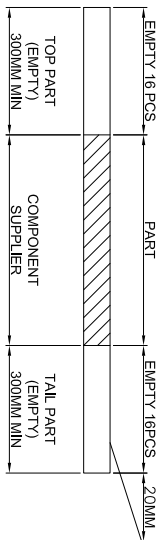

2. 上帶剝力為：0.1~1.3N(10.2gf~130gf)
PEELING OFF FORCE OF TOP TAPE: 0.1~1.3N(10.2gf~130gf)
出貨運輸過程中一定注意：
THIS REQUIREMENT SHOULD BE APPLIED AT SHIPMENT：
卷帶在運輸過程中不能鬆開
PEELING OFF SHOULD NOT BE ALLOWED DURING TRANSPORTATION

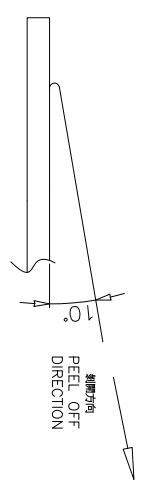

產品圖
PRODUCT CHART DWG

深圳市精拓金电子有限公司

公差一览表 TOLERANCE UNLESS OTHERWISE		單位 UNITS	MM	制圖 DRAWING	F-J	產品料號 PRODUCT PART NO.	USBC TYPE 16PIN ANDP REMALE TOP CONNECTOR (07)0451.PDL 03A
X	±0.25	X'	±5'	審核 CHECK	郭治富	產品名稱 PRODUCT NO.	
.X	±0.20	.X'	±2'	核准 APPRO	黃國榮	角法 VIEW	
.XX	±0.15	.XX'	±1'	日期 DATE	2014/10/20	版本 REV	A0
.XXX	±0.10	.XXX'	±0.5'				

目錄 MAPX	變更內容 MODIFICATION	日期 DATE
------------	----------------------	------------

at small positioning hole of the carrier tape side).
標簽黏貼處 (朝捲裝包材的小定位孔一側)

Location of label sticking (label)

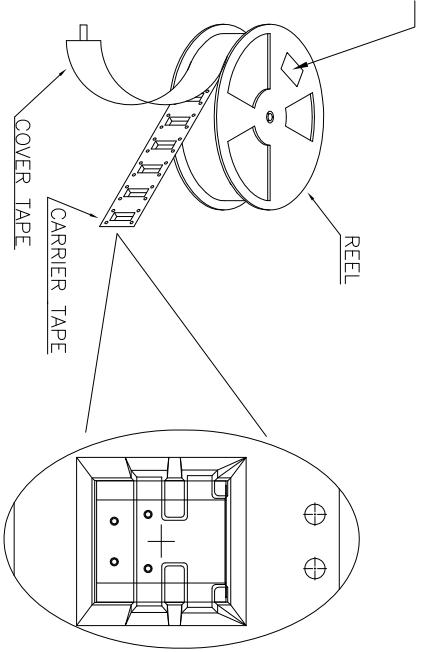
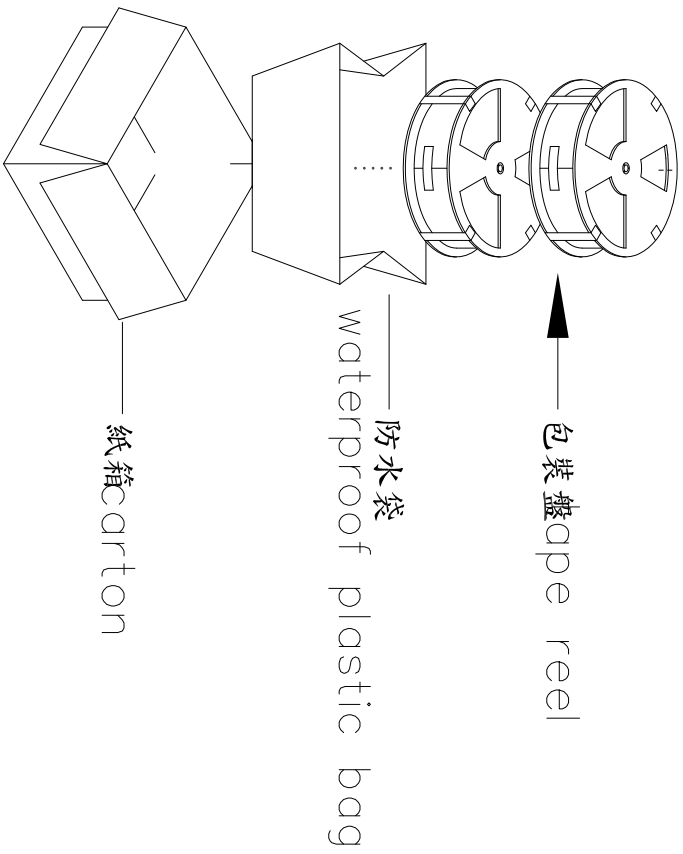

NOTE:

1. 每捲包裝數量及每箱裝箱數量如左下表格.
2. 以上膠帶覆蓋下包裝帶經包裝機冷封包裝
3. 每個紙箱放2個珍珠棉
4. 將裝滿產品的卷盤放入紙箱并以膠帶封口

產品圖
PRODUCT CHART DWG

深圳市精拓金电子有限公司

公差一覽表 TOLERANCE UNLESS OTHERWISE		單位 UNITS	MM	制圖 DRAWING	F-J	產品料號 PRODUCT PART NO.	
X	±0.25	X'	±5'	審核 CHECK	郭治富	產品名稱 PRODUCT NO.	US&C TYPE 6PIN ANDIP REMALE TOP CONNECTOR
.X	±0.20	.X'	±2'	日期 DATE	2014/10/20	角法 VIEW	US&C TYPE 6PIN ANDIP REMALE TOP CONNECTOR
.XX	±0.15	.XX'	±1'	核准 APPRO	黃國榮		
.XXX	±0.10	.XXX'	±0.5'				

產品料號 (PRODUCT No.)	包裝容量 (PACKING CAPACITY)	重量 WEIGHT (KG)
PS/REEL	REEL/CARTON	N.W./PCS
1000	10	N.W./BOX
		G.W./BOX
		10000

