

RoHS

MAPX

MODIFICATION

DRW

DATE

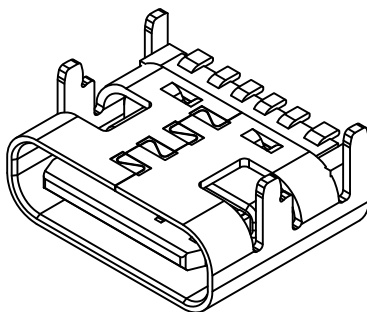
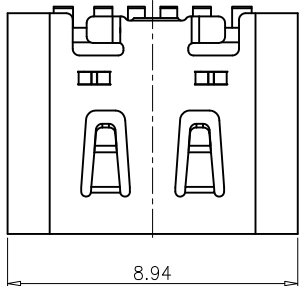

NOTE1:

1.MATERIAL SPECIFICATION:

- 1.HOUSING:HIGH TEMPERATURE RESISTANT PLASTIC,UL94 V-0.
- 2.CONTACTS:COPPER ALLOY
- 3.MID PLATE: STAINLESS STEEL
- 4.FRONT SHELL: STAINLESS STEEL

2.PLATING SPECIFICATION:

- 2-1.CONTACTS:
Ni 50u" MIN. UNDER PLATED OVER ALL.
Au PLATED ON THE FUNCTIONAL AREA OF CONTACT.
(GOLD PLATING THICKNESS FOLLOW THE P/N)
PLATING SPECIFICATIONS OF THE SOLDER AREA FOLLOW THE P/N

2-2.FRONT SHELL:

- SEE TABLE1.
- 2-3.SHIELD PLATE&EMI PLATE:
CLEAR ONLY

3.MECHANICAL PERFORMANCE,

- 3-1.INSERTION FORCE: 0.5~2.0kgf.
- 3-2.REMOVAL FORCE: 0.8kgf~2.0kgf.
- 3-3.DURABILITY: 2000 CYCLES.

4.ELECTRICAL PERFORMANCE,

- 4-1. CURRENT RATING:5.0A
VOLTAGE RATING:5.0V
- 4-2. LLCR:
VBUS & GND PINS AND OTHER PINS: 40mΩ/PIN MAX.
SHIELD: 50mΩ/MAX.
LLCR MAX. CHANGE OF ALL PINS: 10mΩ.
- 4-3.INSULATION RESISTANCE: 100MΩ MIN
- 4-4.DIELECTRIC WITHSTAND VOLTAGE,AC 100V FOR 1 MINUTE.

5. ENVIRONMENTAL PERFORMANCE:

- OPERATING TEMPERATURE: -25°C~+85°C.

6.IR REFLOW:

- THE PEAK TEMPERATURE ON THE BOARD SHALL
BE MAINTAINED FOR 10 SECONDS AT 260°C.

7.COMPLY WITH RoHS 2.0 AND REACH AND OTHER ENVIRONMENTAL
PROTECTION REQUIREMENTS

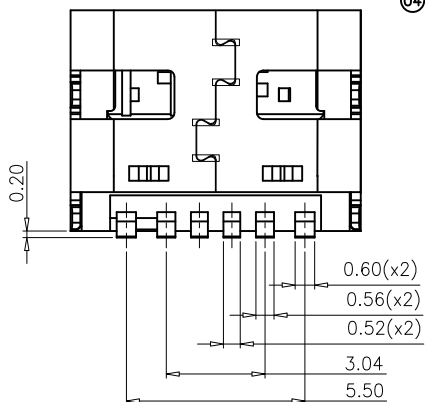
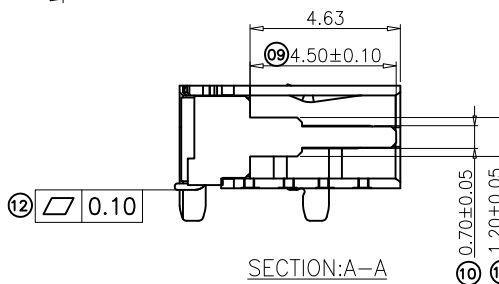
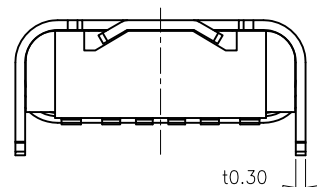
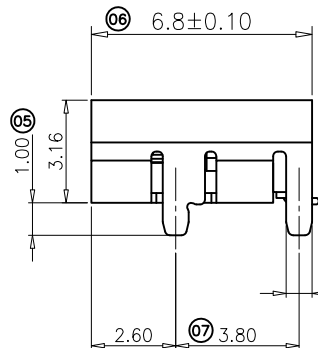
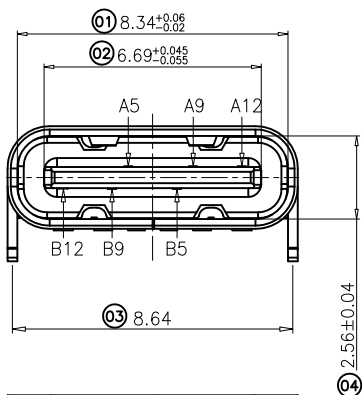

产品图 PRODUCT CHART DWG		深圳市精拓金电子有限公司 Shenzhen Jing Tuo Jin Electronics Co., Ltd.							
公差一览表 TOLERANCE UNLESS OTHERWISE		单位 UNITS	MM	制图 DRAWING	YANG	制图料号 PRODUCT PART NO.	918-418K2023S40044		
X.	±0.25	X.	±5°	比例 SCALE	1:1	审核 CHKD	郭治富	产品名称 PRODUCT NAME	TYPE-C3.1母座6.8四脚1.0插板 6.69/8.64有弹单排LCP黑胶SMT 6PIN
.X	±0.20	.X	±2°	日期 DATE	2020-05-22	核准 APPD	黄国荣	角法 VIEW	版本 VER
.XX	±0.05	.XX	±1°						AD
.XXX	±0.02	.XXX	±0.5°						