

2A 27V Synchronous Buck Converter

Features

- 2A Output Current
- Wide 4.5V to 27V Operating Input Range
- Integrated Power MOSFET switches
- Output Adjustable from 0.925V to 0.8Vin Up to 96% Efficiency
- Programmable Soft-Start
- Stable with Low ESR Ceramic Output Capacitors
- Fixed 340KHz Frequency
- Cycle-by-Cycle Over Current Protection
- Short Circuit Protection
- Input Under Voltage Lockout
- Package: ESOP8

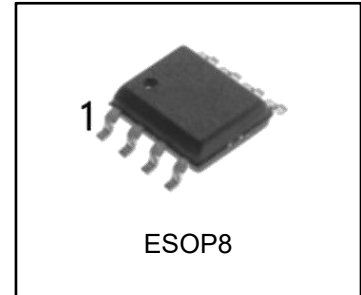

Ordering Information

DEVICE	Package Type	MARKING	Packing	Packing Qty
MP1482ME/TR	ESOP8	MP1482	REEL	2500pcs/Reel

Description

The MP1482 is a monolithic synchronous buck regulator. The device integrates 95 mΩ MOSFETS that provide 2A continuous load current over a wide operating input voltage of 4.5V to 27V. Current mode control provides fast transient response and cycle-by-cycle current limit. An adjustable soft-start prevents inrush current at turn on.

Applications

- Distributed Power Systems
- Networking Systems
- FPGA, DSP, ASIC Power Supplies
- Green Electronics/ Appliances
- Notebook Computers

Typical Application Circuit

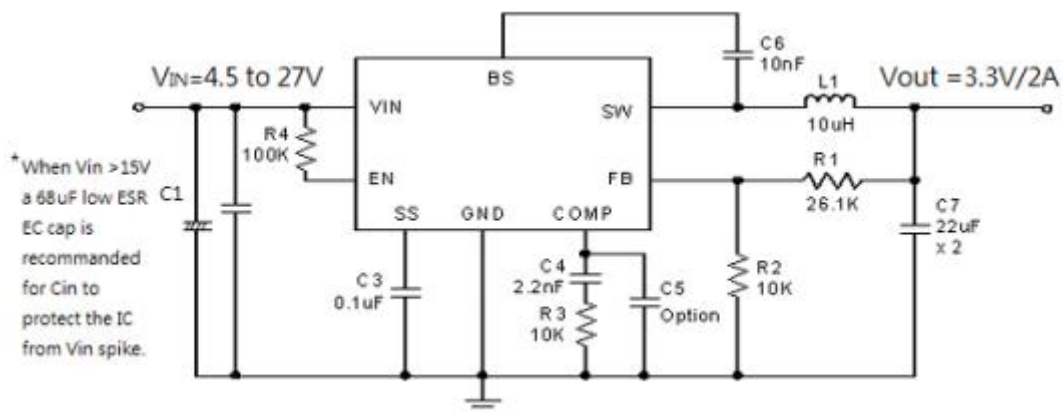

Pin Assignments

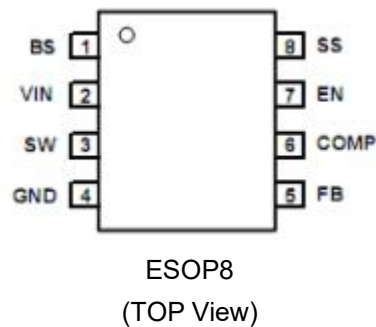

Pin Descriptions

Pin Number	Name	Description
1	BS	Bootstrap. This pin acts as the positive rail for the high-side switch's gate driver. Connect a 0.01uF capacitor between BS and SW.
2	VIN	Input Supply. Bypass this pin to GND with a low ESR capacitor. See Input Capacitor in the Application Information section.
3	SW	Switch Output. Connect this pin to the switching end of the inductor.
4	GND	Ground.
5	FB	Feedback Input. The voltage at this pin is regulated to 0.925V. Connect to the resistor divider between output and ground to set output voltage.
6	COMP	Compensation Pin. See Stability Compensation in the Application Information section.
7	EN	Enable Input. When higher than 2.7V, this pin turns the IC on. When lower than 1.1V, this pin turns the IC off. Output voltage is discharged when the IC is off. This pin should not be left open. Recommend to put a 100KΩ pull up resistor to Vin for startup.
8	SS	Soft-Start Control Input. SS controls the soft-start period. Connect a capacitor from SS to GND to set the soft-start period. A 0.1uF capacitor sets the soft-start period to 15ms. To disable the soft-start feature, leave SS unconnected.

Block Diagram

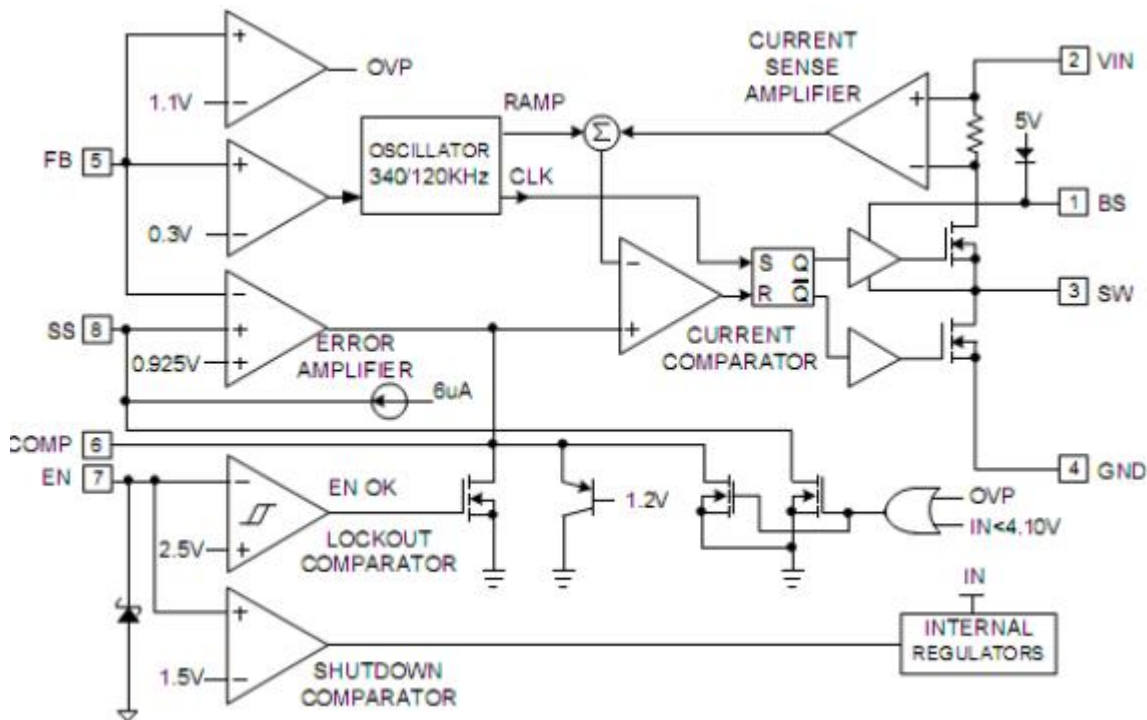

Absolute Maximum Ratings

Parameter	Value	Unit
Input Supply Voltage	-0.3 to 30	V
SW Voltage	-0.3 to VIN + 0.3	V
BS Voltage	VSW - 0.3 to VSW + 6	V
EN, FB, COMP Voltage	-0.3 to 5.	V
Continuous SW Current	Internally limited	A
Junction to Ambient Thermal Resistance (θJA) (Test on Approximately 3 in2 Copper Area 1oz copper FR4 board)	87	°C/W
SOP-8L Power Dissipation	Internal limit	W
Maximum Junction Temperature	150	°C
Storage Temperature Range	-65 to 150	°C
Moisture Sensitivity (MSL)	Please refer the MSL Label on the IC package bag/carton for detail	

(Note: Exceeding these limits may damage the device., Even the duration of exceeding is very short. Exposure to absolute maximum rating conditions for long periods may affect device reliability.)

Recommended Operating Conditions

Parameter	Min	Max	Unit
Input Supply Voltage	4.5	27(1)	V
Operating Junction Temperature	-20	+125(2)	°C

(Note (1): Operating the IC over this voltage is very easy to cause over voltage condition to VIN pin, SW pin, BS pin & EN pin)

(Note (2): If the IC experienced OTP, then the temperature may need to drop to <125 degree C to let the IC recover.)

Electrical Characteristics (V_{IN} = 12V, T_A = 25°C unless otherwise specified.)

Parameter	Symbol	Test Conditions	Min	Typ	Max	Unit
Feedback Voltage	V _{FB}	4.5V ≤ V _{IN} ≤ 27V	0.900	0.925	0.950	V
Feedback Overvoltage Threshold				1.1		V
High-Side Switch-On Resistance*				95		mΩ
Low-Side Switch-On Resistance*				95		mΩ
High-Side Switch Leakage		V _{EN} = 0V, V _{SW} = 0V			10	uA
Upper Switch Current Limit*		Minimum Duty Cycle	2.7	3.5		A
COMP to Current Limit Trans conductance	G _{COMP}			3.3		A/V
Error Amplifier Trans conductance	G _{EA}	ΔI _{COMP} = ±10uA		920		uA/V
Error Amplifier DC Gain*	A _{VEA}			480		V/V
Switching Frequency	f _{SW}			340		KHz
Short Circuit Switching Frequency		V _{FB} = 0		120		KHz
Maximum Duty Cycle	D _{MAX}	V _{FB} = 0.8V		92		%
Minimum On Time*				220		nS
EN Shutdown Threshold Voltage		V _{EN} Rising	1.1	1.4	2	V
EN Shutdown Threshold Voltage Hysteresis				180		mV
EN Lockout Threshold Voltage			2.2	2.5	2.7	V
EN Lockout Hysteresis				130		mV
Supply Current in Shutdown		V _{EN} = 0		0.3	3.0	uA
IC Supply Current in Operation		V _{EN} = 3V, V _{FB} = 1.0V		1.3	1.5	mA
Input UVLO Threshold Rising	UVLO	V _{EN} Rising	3.80	4.05	4.40	V
Input UVLO Threshold Hysteresis				100		mV
Soft-start Current		V _{SS} = 0V		6		uA
Soft-start Period		C _{SS} = 0.1uF		15		mS
Thermal Shutdown Temperature*		Hysteresis = 25°C		160		°C

Application Description

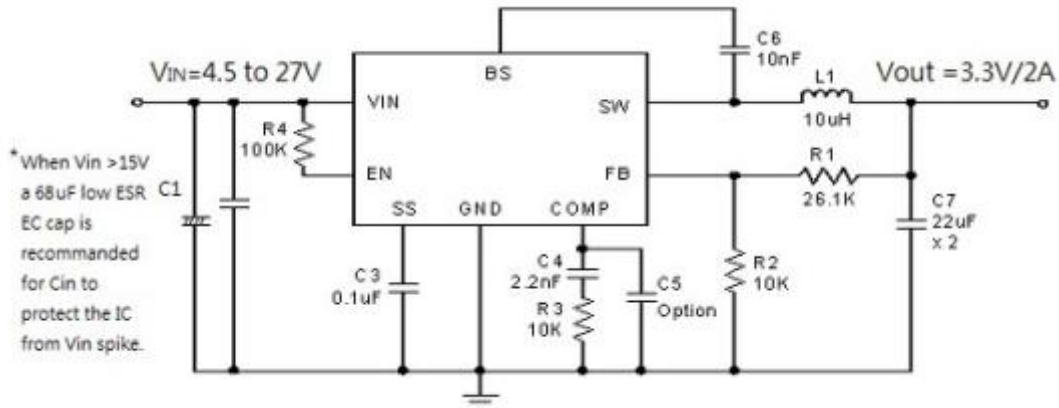

MP1482 Circuit, 3.3V/2A output

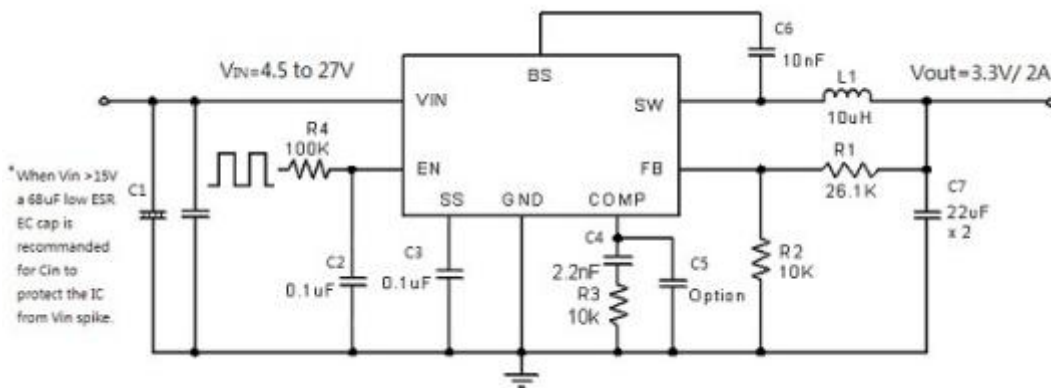

MP1482 Circuit, 3.3V/2A output with EN function

Note: C2 is required for separate EN signal.

Output Voltage Setting

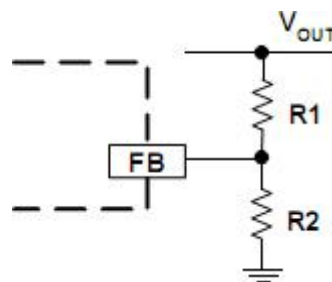

Figure1. Output Voltage Setting

Figure 1 shows the connections for setting the output voltage. Select the proper ratio of the two feedback resistors R1 and R2 based on the output voltage. Typically, use $R2 \approx 10K\Omega$ and determine R1 from the following equation:

$$R1 = R2 \left(\frac{V_{OUT}}{0.925V} - 1 \right) \quad (1)$$

Table1 - Recommended Resistance Values

VOUT	R1	R2
1.0V	1.0 KΩ	12 KΩ
1.2V	3.0 KΩ	10 KΩ
1.8V	9.53 KΩ	10 KΩ
2.5V	16.9 KΩ	10 KΩ
3.3V	26.1 KΩ	10 KΩ
5V	44.2 KΩ	10 KΩ
12V	121 KΩ	10 KΩ

Inductor Selection

The inductor maintains a continuous current to the output load. This inductor current has a ripple that is dependent on the inductance value: higher inductance reduces the peak-to-peak ripple current. The tradeoff for high inductance value is the increase in inductor core size and series resistance, and the reduction in current handling capability. In general, select an inductance value L based on the ripple current requirement:

$$L = \frac{V_{OUT} \cdot (V_{IN} - V_{OUT})}{V_{IN} f_{SW} I_{OUTMAX} \times K_{RIPPLE}} \quad (2)$$

Where VIN is the input voltage, VOUT is the output voltage, fSW is the switching frequency, IOUTMAX is the maximum output current, and KRIPPLE is the ripple factor. Typically, choose KRIPPLE = ~ 30% to correspond to the peak-to-peak ripple current being ~30% of the maximum output current.

With this inductor value, the peak inductor current is IOUT · (1 + KRIPPLE / 2). Make sure that this peak inductor current is less than the upper switch current limit. Finally, select the inductor core size so that it does not saturate at the current limit. Typical inductor values for various output voltages are shown in Table 2.

VOUT	1.0V	1.2V	1.5V	1.8V	2.5V	3.3V	5V	9V
L	4.7u	4.7u	10uH	10uH	10uH	10uH	10uH	22uH

Table2. Typical Inductor Values

Input Capacitor

The input capacitor needs to be carefully selected to maintain sufficiently low ripple at the supply input of the converter. A low ESR Electrolytic (EC) capacitor is highly recommended. Since large current flows in and out of this capacitor during switching, its ESR also affects efficiency.

When EC cap is used, the input capacitance needs to be equal to or higher than 68uF. The RMS ripple current rating needs to be higher than 50% of the output current. The input capacitor should be placed close to the VIN and GND pins of the IC, with the shortest traces possible. The input capacitor can be placed a little bit away if a small parallel 0.1uF ceramic capacitor is placed right next to the IC.

When VIN is >15V, pure ceramic Cin (* no EC cap) is not recommended. This is because the ESR of a ceramic cap is often too small, Pure ceramic Cin will work with the parasite inductance of the input trace and forms a Vin resonant tank. When Vin is hot plug in/out, this resonant tank will boost the Vin spike to a very high voltage and damage the IC.

Output Capacitor

The output capacitor also needs to have low ESR to keep low output voltage ripple. In the case of ceramic output capacitors, RESR is very small and does not contribute to the ripple. Therefore, a lower capacitance value can be used for ceramic capacitors. In the case of tantalum or electrolytic capacitors, the ripple is dominated by RESR multiplied by the ripple current. In that case, the output capacitor is chosen to have sufficiently low ESR.

For ceramic output capacitors, typically choose of about 22uF. For tantalum or electrolytic capacitors, choose a capacitor with less than 50mΩ ESR.

Optional Schottky Diode

During the transition between high-side switch and low-side switch, the body diode of the low side power MOSFET conducts the inductor current. The forward voltage of this body diode is high. An optional Schottky diode may be paralleled between the SW pin and GND pin to improve overall efficiency. Table 3 lists example Schottky diodes and their Manufacturers.

Table 3—Diode Selection Guide

Vin max	Part Number	Voltage/Current Rating	Vendor
<20V	B130	30V, 1A	
<20V	SK13	30V, 1A	
>20V	B140	40V, 1A	
>20V	SK14	40V, 1A	

Stability Compensation

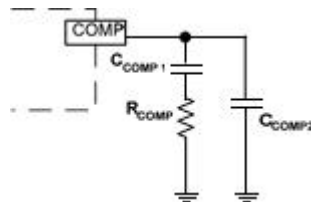

C_COMP2 is needed only for high ESR output capacitor

Figure2. Stability Compensation

The feedback loop of the IC is stabilized by the components at the COMP pin, as shown in Figure 2. The DC loop gain of the system is determined by the following equation:

$$A_{VDC} = \frac{0.925V}{I_{OUT}} A_{VEA} G_{COMP} \quad (4)$$

The dominant pole P1 is due to C_COMP1:

$$f_{F1} = \frac{G_{EA}}{2\pi A_{VEA} C_{COMP1}} \quad (5)$$

The second pole P2 is the output pole:

$$f_{P2} = \frac{I_{OUT}}{2\pi V_{OUT} C_{OUT}} \quad (6)$$

The first zero Z1 is due to RCOMP and CCOMP:

$$f_{Z1} = \frac{1}{2\pi R_{COMP} C_{COMP1}} \quad (7)$$

And finally, the third pole is due to RCOMP and CCOMP2 (if CCOMP2 is used):

$$f_{p3} = \frac{1}{2\pi R_{COMP} C_{COMP2}} \quad (8)$$

The following steps should be used to compensate the IC:

STEP1. Set the crossover frequency at 1/10 of the switching frequency via RCOMP:

$$R_{COMP} = \frac{2\pi V_{OUT} C_{OUT} f_{SW}}{10 G_{EA} G_{COMP} \bullet 0.925V} \quad (9)$$

But limit RCOMP to 10KΩ maximum. More than 10 KΩ is easy to cause overshoot at power on.

STEP2. Set the zero fZ1 at 1/4 of the crossover frequency. If RCOMP is less than 10KΩ, the equation for CCOMP1 is:

$$C_{COMP1} = \frac{0.637}{R_{COMP} \times f_C} (F) \quad (10)$$

STEP3. If the output capacitor's ESR is high enough to cause a zero at lower than 4 times the crossover frequency, an additional compensation capacitor CCOMP2 is required. The condition for using CCOMP2 is:

$$\pi \times C_{OUT} \times R_{ESR} \times f_s \geq 1 \quad (11)$$

And the proper value for CCOMP2 is:

$$C_{COMP2} = \frac{C_{OUT} R_{ESR} C_{UT}}{R_{COMP}} \quad (12)$$

Though CCOMP2 is unnecessary when the output capacitor has sufficiently low ESR, a small value CCOMP2 such as 100pF may improve stability against PCB layout parasitic effects

Table 4—Component Selection Guide for Stability Compensation

Vin Rang(V)	Vout (V)	Cout	Rcomp (R3) (kΩ)	Ccomp (C4) (nF)	Ccomp2 (C5) (pF)	Inductor (uH)
5 - 12	1.0	22uF x2 Ceramic	3.3	5.6	none	4.7
5 - 15	1.2		3.9	4.7	none	4.7
5 - 15	1.8		5.6	3.3	none	10
5 - 15	2.5		8.2	2.2	none	10
5 - 15	3.3		10	2	none	10
7 - 15	5		10	3.3	none	10
5 - 12	1.0	470uF/6.3V/ 120mΩ	10	6.8	680	4.7
5 - 15	1.2					10
5 - 23	1.8					
5 - 27	2.5					
5 - 27	3.3					
7 - 27	5					

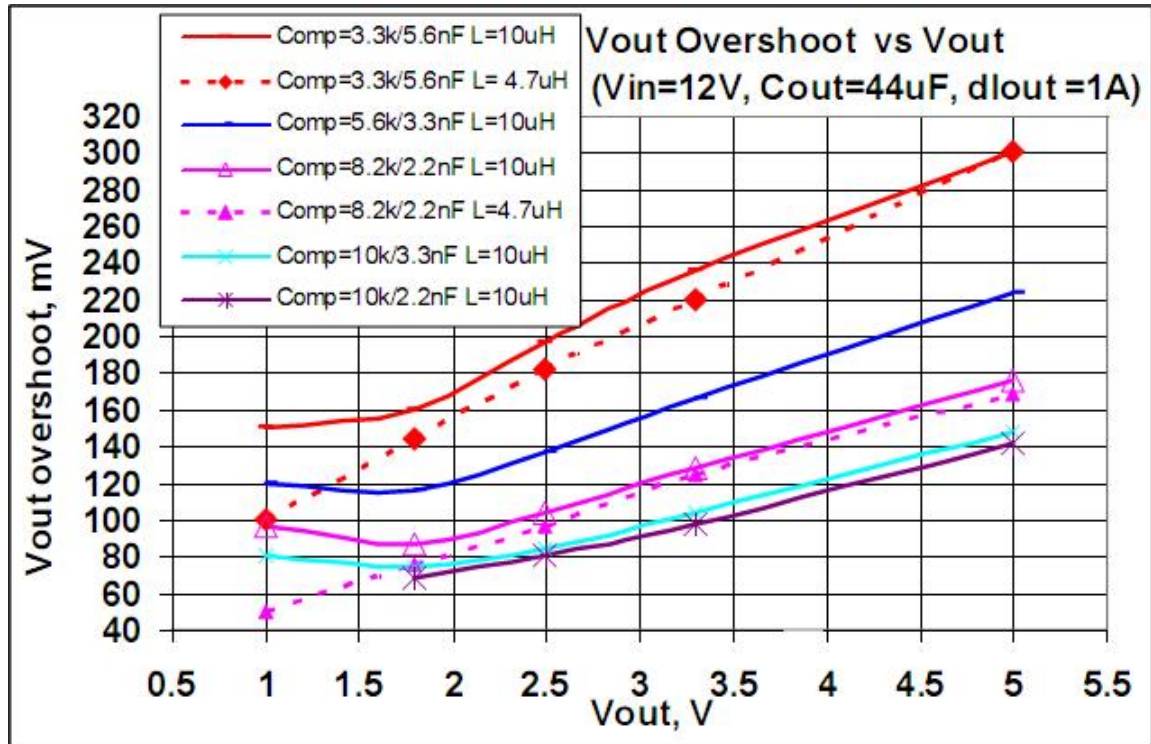

Figure3. Load Transient Testing vs Compensation Value

Typical Performance Characteristics

(VIN=12V, Io=0 mA, Temperature = 25 degree C, unless otherwise specified)

Light Load Operation (No load) Heavy Load Operation (2A Load)

VIN=12V, Iin=8.2 mA, Vout=3,3V VIN=12V, Vout=3,3V

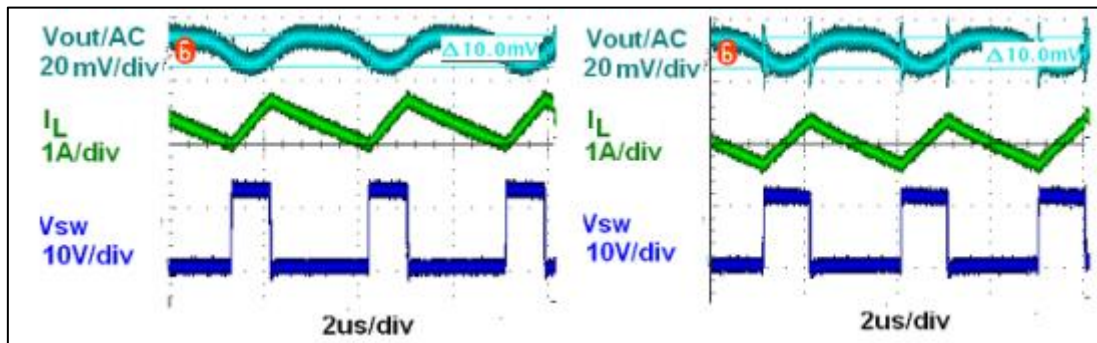

Startup Vin=12V, Vout=3.3V, Iout=1A

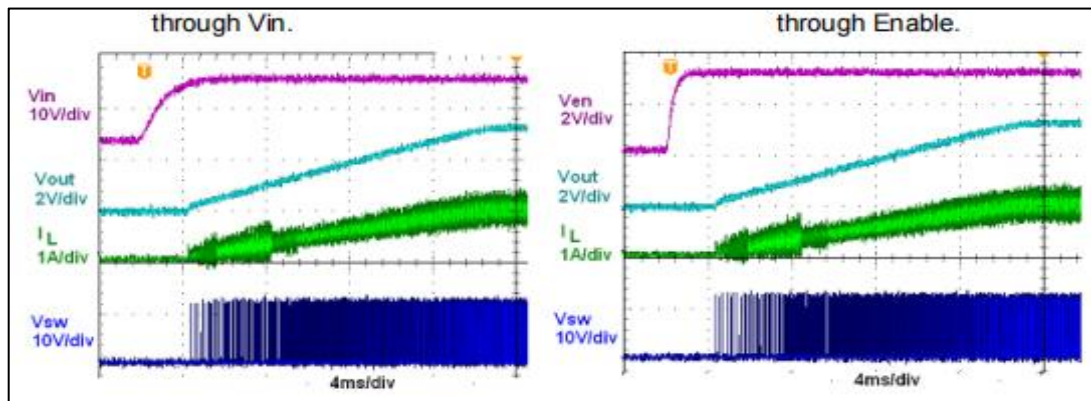

Short Circuit Protection Vin=12V

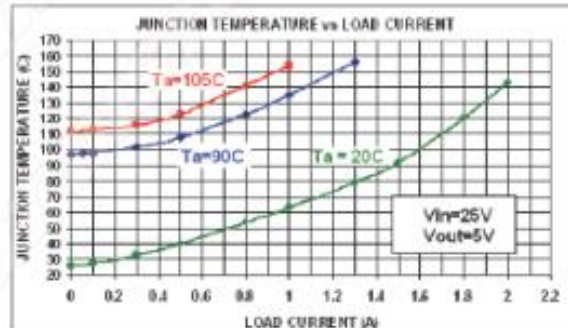
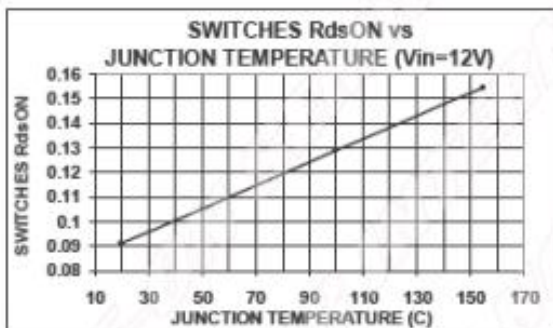
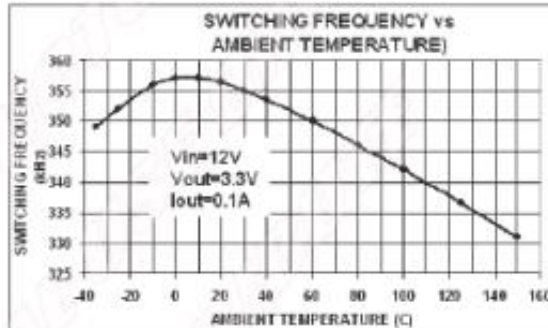
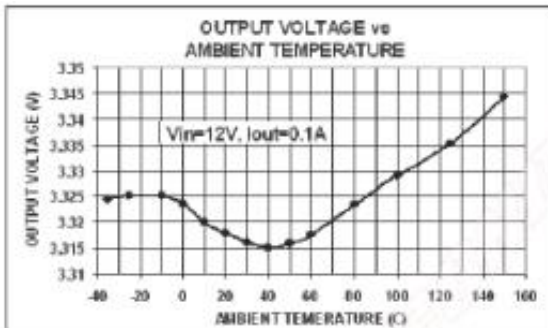
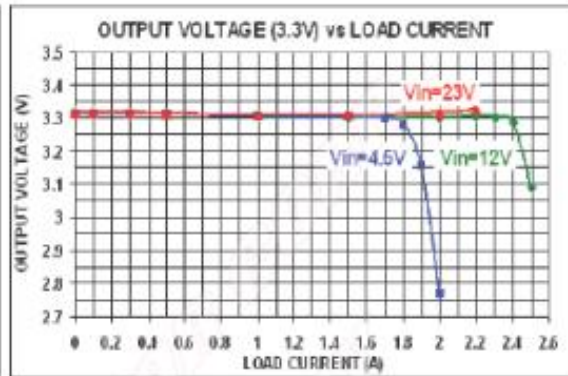
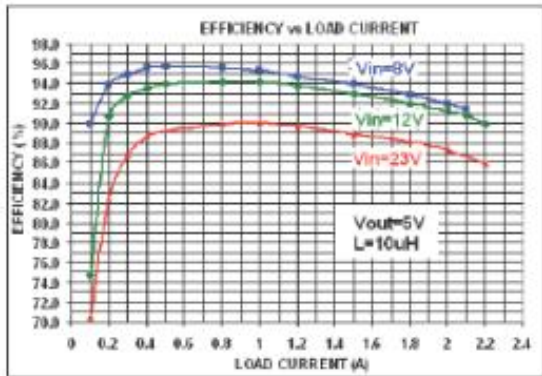
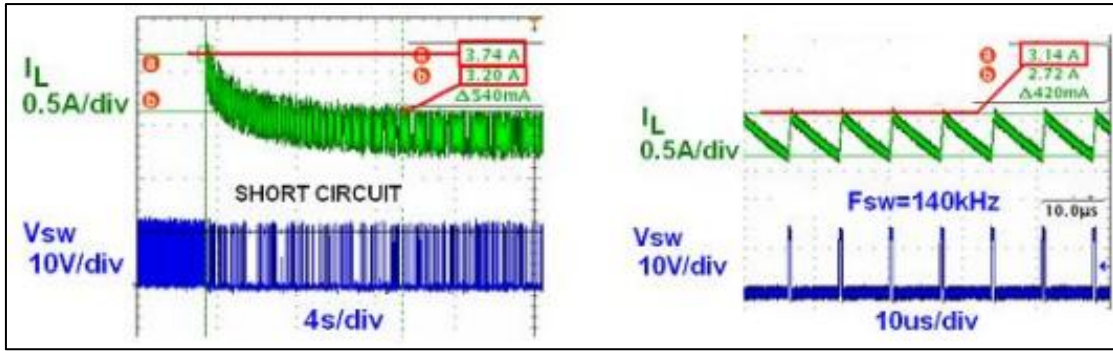

Physical Dimensions

ESOP8

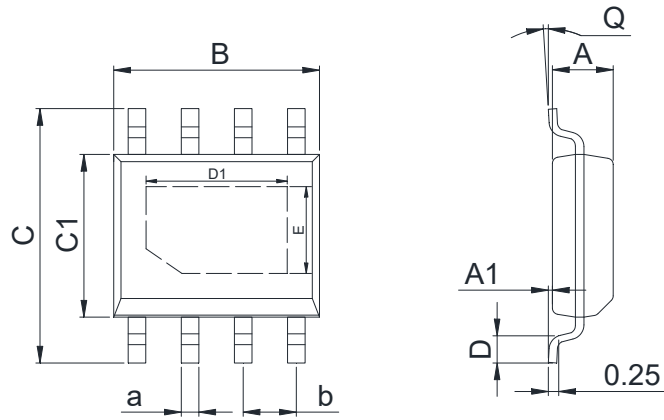

Dimensions In Millimeters(ESOP8)											
Symbol:	A	A1	B	C	C1	D	D1	E	Q	a	b
Min:	1.35	0.05	4.90	5.80	3.80	0.40	3.20	2.31	0°	0.35	1.27 BSC
Max:	1.55	0.20	5.10	6.20	4.00	0.80	3.40	2.51	8°	0.45	

IMPORTANT STATEMENT:

Huaguan Semiconductor reserves the right to change its products and services without notice. Before ordering, the customer shall obtain the latest relevant information and verify whether the information is up to date and complete. Huaguan Semiconductor does not assume any responsibility or obligation for the altered documents.

Customers are responsible for complying with safety standards and taking safety measures when using Huaguan Semiconductor products for system design and machine manufacturing. You will bear all the following responsibilities: select the appropriate Huaguan Semiconductor products for your application; Design, validate and test your application; Ensure that your application meets the appropriate standards and any other safety, security or other requirements. To avoid the occurrence of potential risks that may lead to personal injury or property loss.

Huaguan Semiconductor products have not been approved for applications in life support, military, aerospace and other fields, and Huaguan Semiconductor will not bear the consequences caused by the application of products in these fields.

The technical and reliability data (including data sheets), design resources (including reference designs), application or other design suggestions, network tools, safety information and other resources provided for the performance of semiconductor products produced by Huaguan Semiconductor are not guaranteed to be free from defects and no warranty, express or implied, is made. The use of testing and other quality control technologies is limited to the quality assurance scope of Huaguan Semiconductor. Not all parameters of each device need to be tested.

The documentation of Huaguan Semiconductor authorizes you to use these resources only for developing the application of the product described in this document. You have no right to use any other Huaguan Semiconductor intellectual property rights or any third party intellectual property rights. It is strictly forbidden to make other copies or displays of these resources. You should fully compensate Huaguan Semiconductor and its agents for any claims, damages, costs, losses and debts caused by the use of these resources. Huaguan Semiconductor accepts no liability for any loss or damage caused by infringement.