

DATA SHEET

SKY77912-61 Tx-Rx Front-End Module for Quad-Band GSM / GPRS / EDGE w/ 10 Linear TRx Switch Ports, Dual-Band TD-SCDMA, and TDD LTE Band 39

Applications

- Cellular handsets encompassing Quad-Band GSM/EDGE, Dual-Band TD-SCDMA, and TDD LTE
 - Class 4 GSM850/900
 - Class 1 DCS1800/PCS1900
 - Class 12 GPRS multi-slot operation
 - Linear EDGE operation
 - TD-SCDMA Bands 34/39
 - TDD LTE Band 39

Features

- MIPI® RFFE control with dual-standard support
 - User-selectable register mappings
 - Linear or VRAMP-based GMSK power control
- RF ports internally matched to 50 Ω load
- High Efficiency (inclusive of coupler)
 - 40% GSM850 31% DCS1800
 - 40% GSM900 33% PCS1900
- Tx harmonics below -40 dBm
- Supports APT, buck DC-DC supply
- 10 low insertion loss/high linearity TRx switch ports
- RF input switching to 3G/4G path
- Integrated broadband directional coupler
- Built-in IEC-compliant antenna ESD protection
- High impedance control inputs: 20 μA, maximum
- Current limiting and over-voltage protection for ruggedness and extended battery life
- Power control circuitry built-in for improved TRP variation
- Small, low profile package
 - 5.5 mm x 5.3 mm x 0.71 mm
 - 38-pad configuration
- Supports Uplink Carrier Aggregation in Band 39 (35 MHz)



Skyworks Green™ products are compliant with all applicable legislation and are halogen-free. For additional information, refer to Skyworks *Definition of Green™*, document number SQ04-0074.

Description

SKY77912-61 is a Tx-Rx Front-End Module (FEM) which offers the complete transmit VCO-to-Antenna and Antenna-to-receive SAW filter solution for advanced cellular handsets comprising quad-band GSM, GPRS, EDGE multi-slot operation, and TD-SCDMA and TDD LTE transmission. The FEM fully enables broadband 3G/4G RF switch-through, outward switching of the Power Amplifier (PA) RF inputs, 10 transmit / receive (TRx) antenna switch ports, and an integrated directional coupler.

A new multi-standard CMOS controller provides PA band/mode selection and bias control, including the Mobile Industry Processor Interface (MIPI®) RFFE logic, and switch decoder circuitry. The controller supports user-optional control of linear RF or analog VRAMP of the GMSK envelope. A distinct MIPI register mapping included in this Data Sheet provides for each of these control paradigms, including associated approaches to PA and switch control.

The Heterojunction Bipolar Transistor (HBT) PA blocks are fabricated in Gallium Arsenide (GaAs). The low band (LB) PA transmits in the GSM850/900 bands. The high band (HB) PA supports DCS, PCS, TD-SCDMA bands 34/39, and TDD LTE band 39. The HBT, switch, and controller die, and passive components mount onto a multi-layer laminate substrate and the entire assembly encapsulated with plastic over-mold.

Built into the SKY77912-61 is a complete features set for state-of-the-art performance and minimal phone board complexity, including PA over-voltage and over-current protection, 50 ohms matching and zero DC offset on all RF pins, TRx high linearity/low loss switching and high off-state isolation, integrated directional coupler, IEC ruggedness at antenna output, LB and HB input switching for alternate RF routing 3G/4G Tx paths, power supply pads shared between LB and HB, and ultra-low leakage currents for long standby times.

Selecting the linear-GMSK operation standard disables VRAMP input so all PA biasing depends only on MIPI mode selection. The transmitted envelope is a linear function of RF input.

Selecting VRAMP-enabled operation, the PA controller provides VRAMP control of the GMSK envelope and reduces sensitivity to input drive, temperature, power supply, and process variations. Skyworks' Finger-Based Integrated Power Amplifier Control (FB-iPAC) minimizes output power variation into mismatch. In EDGE and TD-SCDMA / TDD LTE linear modes, VRAMP voltage and MIPI-based bias settings jointly optimize PA linearity and efficiency.

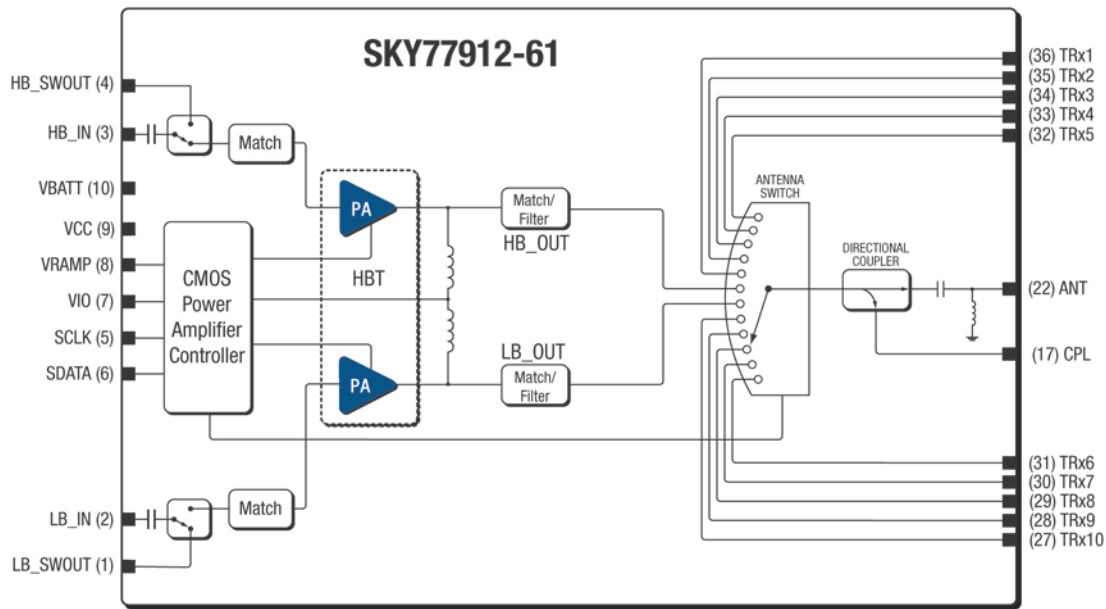

203954_001

Figure 1. SKY77912-61 Functional Block Diagram

Electrical Specifications

The following tables list the electrical specifications of the SKY77912-61 Front-End Module. Table 1 lists the absolute maximum ratings and Table 2 lists the recommended operating conditions. Table 5 through Table 14 provide the electrical specifications of the SKY77912-61 for GMSK, EDGE, TD-SCDMA,

and TDD LTE transmission, and TRx port modes including control logic descriptions for the various modes.

The SKY77912-61 is a static-sensitive electronic device and should not be stored or operated near strong electrostatic fields. Detailed information on device dimensions, pad descriptions, packaging and handling can be found in later sections of this data sheet.

Table 1. Absolute Maximum Ratings¹

Parameter	Symbol	Min	Nominal	Max	Unit
Input Power	P _{IN}	—	—	15	dBm
Supply Voltage ≤ 1 μs (measured to GND)	V _{BATT}	1.2 ²	—	6.0	V
	V _{CC}	0.5	—	6.0 ³	V
DC Continuous During Burst ⁴	I _{BATT}	—	—	2.5	A
GMSK Burst Duty Cycle	D _B	—	—	50	%
Voltage Standing Wave Ratio	V _{SWR}	—	—	20:1	V
Power Control Voltage	V _{RAMP}	-0.3	—	3.0	V
MIPI Supply Voltage	V _{IO}	—	—	2.0	V
MIPI Data and Clock Voltage	V _{MIPI}	—	—	2.0	V
Temperatures	Operating	T _{CASE}	-30	+100	°C
	Storage	T _{STG}	-40	+150	
Moisture Sensitivity Level	MSL	—	—	3	
Reflow Solder Temperature (J-STD-020B)	T _{SOLDER}	260	—	—	°C

¹ Exposure to maximum rating conditions for extended periods may reduce device reliability. There is no damage to device with only one parameter set at the limit at a time and all other parameters set at or below their nominal value.

² Pulsed at -1.2 V for 100 μs.

³ Applies when V_{cc} and V_{batt} are tied together

⁴ Applied voltage must be current-limited to specified range.

Table 2. SKY77912-61 Recommended Operating Conditions¹

Unless otherwise specified: 50 Ω system; terminate all RF ports with 50 Ω during test.

Parameter	Symbol	Min	Typ ²	Max	Unit
Supply Voltage ³	GMSK	3.0	3.5	4.6	V
	EDGE/TD-SCDMA/TDD LTE	3.0	3.6	4.6	
	VCC	3.0	—	4.6	
APT Supply Voltage	VBATT	0.5	3.6	4.3	V
GMSK Input Power – VRAMP-Based Operation	PIN	0	3	6	dBm
Operating Case Temperature ⁴	GMSK/EDGE 1–4 Slots (12.5%–50% duty cycle) ⁵	–20	+25	+85	°C
	TD-SCDMA/TDD LTE	–20	+25	+85	

¹ Extreme Test Conditions (ETC) are defined by the applicable min/max values of the parameters.

² Nominal Test Condition (NTC) is defined by the applicable typical values.

³ VBATT and VCC should be connected unless DC/DC is used and VCC can be separately supplied. In 3G/4G TRx switch-through modes, VBATT may be set to 0 V.

⁴ Case Operating Temperature refers to the temperature at the GROUND PAD on the underside of the package.

⁵ Max. output power must be reduced by 6 dB to support 3-slot and 4-slot operation.

Table 3. SKY77912-61 Interface Specifications

Unless otherwise specified: ETC per Table 2.

Parameter	Symbol	Conditions	Min	Typ	Max	Units
PA Supply Current (on VBATT)	IBATT		0	—	2.5	A
GMSK/EDGE Burst Duty Cycle	DB		12.5	—	50	%
Resistance of VRAMP	R_VRAMP	DC resistance to ground	5	—	—	MΩ
Capacitance of VRAMP	C_VRAMP	Capacitance to ground	—	—	2	pF
MIPI Supply Voltage	VIO	VRAMP < 1.45 V	1.65	1.8	1.95	V
MIPI Signal Levels	VMIPI_LOW		0		0.2 x VIO	
	VMIPI_HIGH		0.8 x VIO		VIO	
Power Control Voltage	VRAMP		0.2	—	1.6	V
Standby Current	I_STANDBY	Standby mode, NTC, VIO = 0 V	—	5	20	μA
TRx Mode Current	I_TRX	Any TRx Mode	—	150	300	μA

Table 4. SKY77912-61 Linear GMSK/EDGE Power Modes -- Recommended Maximum Operating Power

Unless otherwise specified: Values are used as each Power Mode's PRATED Test Condition

Band	Waveform	Power Mode	PRATED	Unit
LB	GMSK	High Power Mode (HPM)	33.5	dBm
		Medium Power Mode (MPM)	29.0	
		Low Power Mode (LPM)	23.0	
		Ultra-Low Power Mode (ULPM)	15	
	EDGE	Medium Power Mode (MPM)	27.5	
		Low Power Mode (LPM)	21.5	
HB	GMSK	High Power Mode (HPM)	30.8	
		Medium Power Mode (MPM)	28.5	
		Low Power Mode (LPM)	22.5	
		Ultra-Low Power Mode (ULPM)	14.5	
	EDGE	Medium Power Mode (MPM)	26.5	
		Low Power Mode (LPM)	20.5	
		Ultra-Low Power Mode (ULPM)	14.5	

Table 5-1. SKY77912-61 ELECTRICAL SPECIFICATIONS – GMSK/EDGE Low Band (Linear GMSK Operation)

Unless otherwise specified: Conditions NTC per Table 2; Duty Cycle 25%; P_{OUT} = P_{PRATED} per "Power Modes" Table 4 at NTC, then varies with gain

Parameter	Symbol	Waveform/ Bias Mode	Condition	Min	Typ	Max	Units
Operating Frequency Range				824		915	MHz
Psat	PSAT_GMSK	GMSK HPM	P _{IN} = 9 dBm, NTC	33.5	34.3	—	dBm
Psat Degraded	PSAT_GMSK_ETC	GMSK HPM	P _{IN} = 9 dBm, ETC	31.5		—	dBm
Power Added Efficiency, saturated	PAE_GMSK_SAT	GMSK HPM	NTC P _{OUT} = P _{SAT} , P _{IN} = 9 dBm	—	44	—	%
Power Added Efficiency	PAE_GMSK	GMSK HPM		—	41	—	
		GMSK MPM		—	24.0	—	
		GMSK LPM		—	12.0	—	
		GMSK ULPM		—	4.5	—	
Gain	GAIN_GMSK	GMSK HPM		27.7	29.7	31.7	dB
		GMSK MPM		27.5	29.5	31.5	
		GMSK LPM		26.0	28.0	30.0	
		GMSK ULPM		16.2	18.7	21.2	
Gain	GAIN_EDGE	EDGE MPM		28.0	30.7	32.7	dB
		EDGE LPM		26.0	28.0	30.0	
		EDGE ULPM		17.7	20.2	21.7	
Gain Compression Over P _{OUT}	ΔGain_P _{OUT}	EDGE MPM	Gain(P _{PRATED}) – Gain(P _{PRATED} – 10 dB)	–1	—	1	dB
		EDGE LPM		–1	—	1	
		EDGE ULPM		–1	—	1	
Gain Change Over Temperature		GMSK HPM	ETC, except V _{BATT} = V _{CC} = 3.5 V	–1.5	—	1	dB
		GMSK MPM		–1.5	—	1.2	
		GMSK LPM		–1.5	—	1.9	
		GMSK ULPM		–2.5	—	2.5	
Gain Change Over Voltage		GMSK ALL	ETC, except T = +25 °C	–0.5	—	1	dB
Power Added Efficiency	PAE_EDGE	EDGE MPM		—	19	—	%

Table 5-2. SKY77912-61 ELECTRICAL SPECIFICATIONS – GMSK/EDGE Low Band (Linear GMSK Operation)

Unless otherwise specified: Conditions NTC per Table 2; Duty Cycle 25%; P_{OUT} = PRATED per "Power Modes" Table 4 at NTC, then varies with gain

Parameter	Symbol	Waveform/ Bias Mode	Condition	Min	Typ	Max	Units
Output Noise Power		ALL	NTC, Rx = 747 MHz to 757 MHz	—	—	-84	dBm/100 kHz
			NTC, Rx = 757 MHz to 762 MHz	—	—	-84	
			NTC, Rx = 869 MHz to 894 MHz	—	—	-84	
			NTC, Rx = 925 MHz to 935 MHz	—	—	-80	
			NTC, Rx = 935 MHz to 960 MHz	—	—	-83	
			NTC, Rx = 1805 MHz to 1880 MHz	—	—	-90	
			NTC, Rx = 1930 MHz to 1990 MHz	—	—	-90	
Harmonics	2f ₀ -13f ₀	GMSK ALL	ETC, P _{OUT} ≤ PRATED	—	—	-33	dBm
Input VSWR	VSWR_IN	ALL	NTC	—	—	2.5:1	
Stability	S	ALL	VSWR ≤ 12:1	—	—	-36	dBm
Ruggedness	Ru	HPM	All Load Phases	15:1	—		
Switching Transients	SWT_400	GMSK HPM	400 kHz offset	—	—	-28	dBm/30kHz
		GMSK MPM	ETC	—	—	-28	
		GMSK LPM	P _{IN} adjusted for Temperature	—	—	-28	
		GMSK ULPM		—	—	-28	
ACPR (M-ORFS, No Predistortion)	ACPR_200	EDGE MPM	200 kHz offset	—	—	-36.5	dBc/30 kHz
		EDGE LPM	ETC ¹	—	—	-36.5	
		EDGE ULPM	P _{IN} adjusted for Temperature	—	—	-36.5	
	ACPR_400	EDGE MPM	400 kHz offset	—	—	-58	
		EDGE LPM	ETC ¹	—	—	-58	
		EDGE ULPM	P _{IN} adjusted for Temperature	—	—	-58	
	ACPR_600	EDGE MPM	600 kHz offset	—	—	-65	
		EDGE LPM	ETC ¹	—	—	-65	
		EDGE ULPM	P _{IN} adjusted for Temperature	—	—	-65	
EVM (No Predistortion)	EVM_rms	EDGE MPM	ETC ¹	—	2.0	3.5	%
		EDGE LPM	P _{IN} adjusted for Temperature	—	2.0	3.5	
		EDGE ULPM		—	2.0	3.5	

¹ ETC condition for EDGE linearity: V_{BATT} ≥ 3.2 V. P_{OUT} = 26.5 dBm at low V_{BATT}.

Table 6-1. SKY77912-61 Electrical Specifications – GMSK Low Band (GSM850/900) GMSK Mode (Vramp-Based Operation)
Unless otherwise specified: PRATED = 33 dBm; ETC per Table 2.

Parameter	Symbol	Conditions	Min	Typ	Max	Unit	
Frequency Range	GSM850	f_0	—	824	—	849	MHz
	GSM900			880	—	915	
Output Power	POUT_GMSK	PIN = 0 dBm VRAMP = 1.65 V NTC	33	34	—	dBm	
	POUT_GMSK_EX	PIN = 0 dBm VBATT = 3.0 V VRAMP = 1.65 V	31	—	—		
Supply Current	IBATT	—	—	—	2.5	A	
Power Added Efficiency	GSM850	PAE POUT = PRATED NTC Duty cycle = 1:8	—	40	—	%	
	GSM900			40	—		
Harmonics	$2f_0$ to $13f_0$	BW = 3 MHz $5 \text{ dBm} \leq \text{Cal-POUT} \leq \text{PRATED}$ $\text{VRAMP} = \text{Cal-VRAMP}^1$	—	-40	-33	dBm	
Input VSWR	VSWR_IN	POUT ≤ PRATED, NTC	—	—	2.5:1		
Isolation	ISO_PDSD	PIN ≤ 6 dBm Isolation Mode VRAMP ≤ 0.1 V	—	-70	-51	dBm	
	ISO_PESE	NTC PIN ≤ 6 dBm LB_GMSK_Tx Mode VRAMP ≤ 0.1 V	—	—	-15		
Mode Switching Time	T_MODE_GMSK	Time from EDGE to GMSK mode transition to application of GMSK RF input drive to meet forward isolation PESE	—	—	2	µs	

Table 6-2. SKY77912-61 Electrical Specifications – GMSK Low Band (GSM850/900) GMSK Mode (Vramp-Based Operation)
Unless otherwise specified: PRATED = 33 dBm; ETC per Table 2.

Parameter	Symbol	Conditions	Min	Typ	Max	Unit	
Stability	S	All combinations of the following parameters: $5 \text{ dBm} \leq P_{\text{OUT}} \leq P_{\text{RATED}}$ Load VSWR = 12:1, all phase angles	No parasitic oscillation > -36 dBm				
Load Mismatch	Load	All combinations of the following parameters: $5 \text{ dBm} \leq P_{\text{OUT}} \leq P_{\text{RATED}}$ Load VSWR = 20:1, all phase angles.	No module damage or permanent degradation				
Noise Power	PNOISE_850	$f_{\text{Rx}} = 869 \text{ MHz to } 894 \text{ MHz}$ $P_{\text{OUT}} = P_{\text{RATED}}$ NTC RBW = 100 kHz	—	—	-83	dBm	
	PNOISE_900	$f_{\text{Rx}} = 935 \text{ MHz to } 960 \text{ MHz}$ $P_{\text{OUT}} = P_{\text{RATED}}$ NTC RBW = 100 kHz	—	—	-83		
		$f_{\text{Rx}} = 925 \text{ MHz to } 935 \text{ MHz}$ $P_{\text{OUT}} = P_{\text{RATED}}$ NTC RBW = 100 kHz	—	—	-79		
		$f_{\text{Rx}} = 1805 \text{ MHz to } 1880 \text{ MHz}$ $P_{\text{OUT}} = P_{\text{RATED}}$ NTC RBW = 100 kHz	—	—	-86		
	PNOISE_750	$f_{\text{Rx}} = 734 \text{ MHz to } 757 \text{ MHz}$ $P_{\text{OUT}} = P_{\text{RATED}}$ NTC RBW = 100 kHz			-83		

¹ Cal-VRAMP = VRAMP at POUT = Cal-POUT, NTC

Table 7-1. SKY77912-61 Electrical Specifications – EDGE Low Band (GSM850/900) EDGE Mode Vramp-Based Operation)

Unless otherwise specified: VRAMP = 1.45 V; PRATED = 27.5 dBm; ETC per Table 2.

Parameter	Symbol	Conditions	Min	Typ	Max	Unit	
Frequency Range	GSM850	f_0	—	824	—	849	MHz
	GSM900			880	—	915	
Output Power	POUT_EDGE	NTC Gain / ACPR / EVM in specification	27.5	—	—	dBm	
	POUT_EDGE_EX	Gain / ACPR / EVM in specification	26.0	—	—		
Gain	G_NOM_850	POUT = PRATED	29.0	30.5	32.5	dB	
	G_NOM_900	NTC	28.7	30.2	31.7		
	G_EX_850	POUT = POUT_EDGE,	27.0	—	33.0		
	G_EX_900	POUT_EDGE_EX	26.7	—	33.0		
Power Added Efficiency	GSM850	POUT = PRATED NTC	—	19	—	%	
	GSM900	Duty cycle = 1:8	—	19	—		
Harmonics	$2f_0$ to $15f_0$	BW = 3 MHz $5 \text{ dBm} \leq \text{POUT} \leq \text{POUT_EDGE}, \text{POUT_EDGE_EX}$	—	-45	-36	dBm	
Input VSWR	VSWR_IN	POUT ≤ PRATED, NTC	—	—	2.5:1		
ACPR	ACPR_200	POUT = POUT_EDGE, POUT_EDGE_EX Bandwidth = 30 kHz	—	-38.0	-36.5	dBc	
	ACPR_400		—	-65.0	-60.0		
	ACPR_600		—	-75.0	-70.0		
EVM	EVM_RMS	POUT = POUT_EDGE, POUT_EDGE_EX	—	2.0	3.5	%	
Bias Switching Time	T_ON_EDGE	Rx to Tx transition time from final MIPI command and 90% VRAMP to 0.5 db RF settling.	—	—	1	μs	

Table 7-2. SKY77912-61 Electrical Specifications – EDGE Low Band (GSM850/900) EDGE Mode (Vramp-Based Operation)

Unless otherwise specified: VRAMP = 1.45 V; PRATED = 27.5 dBm; ETC per Table 2.

Parameter	Symbol	Conditions	Min	Typ	Max	Unit	
Stability	S	All combinations of the following parameters: 5 dBm ≤ P _{OUT} ≤ P _{PRATED} Load VSWR = 12:1, all phase angles	No parasitic oscillation > -36 dBm				
Load Mismatch	Load	All combinations of the following parameters: 5 dBm ≤ P _{OUT} ≤ P _{PRATED} Load VSWR = 20:1, all phase angles.	No module damage or permanent degradation				
Noise Power	P _{NOISE_850}	f _{Rx} = 869 MHz to 894 MHz P _{OUT} = P _{PRATED} NTC RBW = 100 kHz	—	—	-83	dBm	
	P _{NOISE_900}	f _{Rx} = 935 MHz to 960 MHz P _{OUT} = P _{PRATED} NTC RBW = 100 kHz	—	—	-83		
		f _{Rx} = 925 MHz to 935 MHz P _{OUT} = P _{PRATED} NTC RBW = 100 kHz	—	—	-82		
		f _{Rx} = 1805 MHz to 1880 MHz P _{OUT} = P _{PRATED} NTC RBW = 100 kHz	—	—	-86		
	P _{NOISE_750}	f _{Rx} = 734 MHz to 757 MHz P _{OUT} = P _{PRATED} NTC RBW = 100 kHz	—	—	-83		

Table 8-1. SKY77912-61 ELECTRICAL SPECIFICATIONS – GMSK/EDGE High Band (Linear GMSK Operation)

Unless otherwise specified: Conditions NTC per Table 2; Duty Cycle 25%; Pout = Prated per "Power Modes" Table at NTC, then varies with gain

Parameter	Symbol	Waveform/ Bias Mode	Condition	Min	Typ	Max	Units
Operating Frequency Range				1710		1910	MHz
Psat	PSAT_GMSK	GMSK HPM	PIN = 6 dBm, NTC	31.0	32.0	—	dBm
Psat Degraded	PSAT_GMSK_ETC	GMSK HPM	PIN = 6 dBm, ETC	29.0		—	dBm
Power Added Efficiency, saturated	PAE_GMSK_SAT	GMSK HPM	NTC P _{OUT} = P _{SAT} , P _{IN} = 6 dBm	—	36	—	%
Power Added Efficiency	PAE_GMSK	GMSK HPM		—	32.0	—	
		GMSK MPM		—	25.0	—	
		GMSK LPM		—	10.0	—	
		GMSK ULPM		—	3.5	—	
Gain	GAIN_GMSK	GMSK HPM		27.7	29.7	31.7	dB
		GMSK MPM		27.5	29.5	31.5	
		GMSK LPM		26.0	28.0	30.0	
		GMSK ULPM		19.0	21.5	31.5	
Gain	GAIN_EDGE	EDGE MPM		29.5	31.5	33.5	dB
		EDGE LPM		27.5	30.0	31.5	
		EDGE ULPM		19.7	22.2	23.7	
Gain Compression Over P _{OUT}	ΔGain_P _{OUT}	EDGE MPM	Gain(P _{PRATED}) – Gain(P _{PRATED} – 10 dB)	-1	—	1	dB
		EDGE LPM		-1	—	1	
		EDGE ULPM		-1	—	1	
Gain Change Over Temperature		GMSK HPM	ETC, except V _{BATT} = V _{CC} = 3.5 V	-1.5	—	1	dB
		GMSK MPM		-1.5	—	1.2	
		GMSK LPM		-1.5	—	1.3	
		GMSK ULPM		-2.5	—	1.8	
Gain Change Over Voltage		GMSK ALL	ETC, except T = 25 °C	-0.5	—	1	dB
PAE	PAE_EDGE	EDGE MPM		—	17	—	%

Table 8-2. SKY77912-61 ELECTRICAL SPECIFICATIONS – GMSK/EDGE High Band (Linear GMSK Operation)

Unless otherwise specified: Conditions NTC per Table 2; Duty Cycle 25%; Pout = Prated per "Power Modes" Table at NTC, then varies with gain

Parameter	Symbol	Waveform/ Bias Mode	Condition	Min	Typ	Max	Units
Output Noise Power		ALL	NTC, Rx = 747 MHz to 757 MHz	—	—	-93	dBm/100kHz
			NTC, Rx = 757 MHz to 762 MHz	—	—	-93	
			NTC, Rx = 869 MHz to 894 MHz	—	—	-93	
			NTC, Rx = 925 MHz to 935 MHz	—	—	-90	
			NTC, Rx = 935 MHz to 960 MHz	—	—	-90	
			NTC, Rx = 1805 MHz to 1880 MHz	—	—	-81	
			NTC, Rx = 1930 MHz to 1990 MHz	—	—	-82	
Harmonics	$2f_0-13f_0$	GMSK ALL	ETC, POUT ≤ PRATED	—	—	-33	dBm
Input VSWR	VSWR_IN	ALL	NTC	—	—	2.5:1	
Stability	S	ALL	VSWR ≤ 12:1	—	—	-36	dBm
Ruggedness	Ru	HPM	All Load Phases	15:1	—	—	
Switching Transients	SWT_400	GMSK HPM	400 kHz offset	—	—	-28	dBm/30kHz
		GMSK MPM	ETC	—	—	-28	
		GMSK LPM	PIN adjusted for Temperature	—	—	-28	
		GMSK ULPM		—	—	-28	
ACPR (M-ORFS, no pre-distortion)	ACPR_200	EDGE MPM	200 kHz offset	—	—	-36.5	dBc/30kHz
		EDGE LPM	ETC ¹	—	—	-36.5	
		EDGE ULPM	PIN adjusted for Temperature	—	—	-36.5	
	ACPR_400	EDGE MPM	400 kHz offset	—	—	-58	
		EDGE LPM	ETC ¹	—	—	-58	
		EDGE ULPM	PIN adjusted for Temperature	—	—	-58	
	ACPR_600	EDGE MPM	600 kHz offset	—	—	-65	
		EDGE LPM	ETC ¹	—	—	-65	
		EDGE ULPM	PIN adjusted for Temperature	—	—	-65	
EVM (no pre-distortion)	EVM_RMS	EDGE MPM	ETC ¹	—	2.0	3.5	%
		EDGE LPM	PIN adjusted for Temperature	—	2.0	3.5	
		EDGE ULPM		—	2.0	3.5	

¹ ETC condition for EDGE linearity: VBATT ≥ 3.2 V. POUT = 25.5 dBm.

Table 9-1. SKY77912-61 Electrical Specifications – GMSK High Band (GSM1800/1900) GMSK Mode (Vramp-based Operation)
Unless otherwise specified: PRATED = 30.5 dBm; ETC per Table 2.

Parameter	Symbol	Conditions	Min	Typ	Max	Unit	
Frequency Range	DCS1800	fo	—	1710	—	1785	MHz
	PCS1900		—	1850	—	1916	
Output Power	POUT_GMSK	PIN = 0 dBm VRAMP = 1.65 V NTC	31.0	31.5	—	dBm	
	POUT_GMSK_EX	PIN = 0 dBm VBATT = 3.0 V VRAMP = 1.65 V	28.5	—	—		
Power Added Efficiency	PAE_DCS1800	POUT = PRATED NTC Duty cycle = 1:8	—	31	—	%	
	PAE_PCS1900		—	33	—		
Harmonics	2fo to 7fo	BW = 3 MHz 0 dBm ≤ Cal-POUT ≤ PRATED VRAMP = Cal- VRAMP ¹	—	-40	-33	dBm	
Input VSWR	ΓIN	POUT ≤ PRATED, NTC	—	—	2.5:1		
Isolation	ISO_PDSD	PIN ≤ 6 dBm Isolation Mode VRAMP ≤ 0.1 V	—	-65	-53	dBm	
	ISO_PESE	NTC PIN ≤ 6 dBm HB_GMSK_Tx Mode VRAMP ≤ 0.1 V	—	—	-15		
Mode Switching Time	T_MODE_GMSK	Time from EDGE to GMSK mode transition to application of GMSK RF input drive to meet forward isolation PESE	—	—	2	μs	

Table 9-2. SKY77912-61 Electrical Specifications – GMSK High Band (GSM1800/1900) GMSK Mode (Vramp-based Operation)
Unless otherwise specified: PRATED = 30.5 dBm; ETC per Table 2.

Parameter	Symbol	Conditions	Min	Typ	Max	Unit	
Stability	S	All combinations of the following parameters: 0 dBm ≤ P _{OUT} ≤ P _{PRATED} Load VSWR = 12:1, all phase angles	No parasitic oscillation > -36 dBm				
Load Mismatch	Load	All combinations of the following parameters: 0 dBm ≤ P _{OUT} ≤ P _{PRATED} Load VSWR = 20:1, all phase angles.	No module damage or permanent degradation				
Noise Power	P _{NOISE_1800}	f _{Rx} = 1805 MHz to 1880 MHz P _{OUT} = P _{PRATED} NTC RBW = 100 kHz	—	—	-83	dBm	
		f _{Rx} = 925 MHz to 960 MHz P _{OUT} = P _{PRATED} NTC RBW = 100 kHz	—	—	-84		
	P _{NOISE_1900}	f _{Rx} = 1930 MHz to 1990 MHz P _{OUT} = P _{PRATED} NTC RBW = 100 kHz	—	—	-83		
		f _{Rx} = 869 MHz to 894 MHz P _{OUT} = P _{PRATED} NTC RBW = 100 kHz	—	—	-84		
	P _{NOISE_750}	f _{Rx} = 734 MHz to 757 MHz P _{OUT} = P _{PRATED} NTC RBW = 100 kHz	—	—	-83		

¹ Cal-VRAMP = VRAMP at P_{OUT} = Cal-P_{OUT}, NTC

Table 10-1. SKY77912-61 Electrical Specifications –EDGE High Band (GSM1800/1900) EDGE Mode (Vramp-based Operation)
Unless otherwise specified: VrAMP = 1.45 V; PRATED = 26.5 dBm; ETC per Table 2.

Parameter	Symbol	Conditions	Min	Typ	Max	Unit	
Frequency Range	DCS1800	f_0	—	1710	—	1785	MHz
	PCS1900			1850	—	1916	
Output Power	POUT_EDGE	NTC Gain / ACPR / EVM / in specification	26.5	—	—	dBm	
	POUT_EDGE_EX	Gain / ACPR / EVM / in specification	25.0	—	—		
Gain	G_NOM_1800	POUT = PRATED	30.2	31.6	33.7	dB	
	G_NOM_1900	NTC	29.5	31.1	33.0		
	G_EX_1800	POUT = POUT_EDGE,	27.6	—	34.6		
	G_EX_1900	POUT_EDGE_EX	26.6	—	34.1		
Power Added Efficiency	PAE_DCS1800	VBATT = 3.6 V POUT = PRATED	—	17	—	%	
	PAE_PCS1900	NTC Duty cycle = 1:8	—	18	—		
Harmonics	$2f_0$ to $7f_0$	BW = 3 MHz $0 \text{ dBm} \leq \text{POUT} \leq \text{POUT_EDGE}, \text{POUT_EDGE_EX}$	—	-45	-36	dBm	
Input VSWR	Γ_{IN}	POUT ≤ PRATED, NTC	—	—	2.5:1		
ACPR	ACPR_200	POUT = POUT_EDGE, POUT_EDGE_EX Bandwidth = 30 kHz	—	-38.0	-36.5	dBc	
	ACPR_400		—	-65.0	-59.0		
	ACPR_600		—	-75.0	-70.0		
EVM	EVM_RMS	POUT = POUT_EDGE, POUT_EDGE_EX	—	2.0	3.5	%	
Mode Switching Time	T_ON_EDGE	Rx to Tx transition time from final MIPI command and 90% VrAMP to 0.5 dB RF settling	—	—	1	μs	

Table 10-2. SKY77912-61 Electrical Specifications –EDGE High Band (GSM1800/1900) (Vramp-based Operation)

Unless otherwise specified: VRAMP = 1.45 V; PRATED = 26.5 dBm; ETC per Table 2.

Parameter	Symbol	Conditions	Min	Typ	Max	Unit
Stability	S	All combinations of the following parameters: 0 dBm ≤ P _{OUT} ≤ PRATED Load VSWR = 12:1, all phase angles	No parasitic oscillation > -36 dBm			
Load Mismatch	Load	All combinations of the following parameters: 0 dBm ≤ P _{OUT} ≤ PRATED Load VSWR = 20:1, all phase angles	No module damage or permanent degradation			
Noise Power	P _{NOISE_1800}	f _{Rx} = 1805 MHz to 1880 MHz P _{OUT} = PRATED NTC RBW = 100 kHz	—	—	-80	dBm
		f _{Rx} = 925 MHz to 960 MHz P _{OUT} = PRATED NTC RBW = 100 kHz	—	—	-84	
	P _{NOISE_1900}	f _{Rx} = 1930 MHz to 1990 MHz P _{OUT} = PRATED NTC RBW = 100 kHz	—	—	-80	
		f _{Rx} = 869 MHz to 894 MHz P _{OUT} = PRATED NTC RBW = 100 kHz	—	—	-84	
	P _{NOISE_750}	f _{Rx} = 734 MHz to 757 MHz P _{OUT} = PRATED NTC RBW = 100 kHz	—	—	-83	

Table 11. SKY77912-61 Electrical Specifications – TD-SCDMA Band 39 (1880–1920 MHz)

Unless otherwise specified: HPM (Linear GMSK/EDGE Operation); Vramp = 1.45 V (Vramp-based Operation); ETC per Table 2.

Parameters	Symbol	Condition	Min	Typ	Max	Unit	
Output Power	POUT_TD_NOM	NTC	24.5	—	—	dBm	
	POUT_TD_EX		23.5	—	—		
Gain	High Power	GHPM_TDLTE_NOM	POUT = POUT_TD_NOM	27.7	29.9	31.2	dB
		GHPM_EX	POUT = POUT_TD_EX	25.2		32.2	
	Low Power	GLPM	PIN = -35 dBm, VRAMP = 0.3 V	—	17	22	
Power Added Efficiency	PAEHPM	POUT = POUT_TD_NOM	—	13.5	—	%	
Adjacent Channel Leakage power Ratio ¹	1.6 MHz offset	ACLR1.6	POUT_TD_NOM	—	-47	-42	dBc
			POUT_TD_EX	—	—	-38	
	3.2 MHz offset	ACLR3.2	POUT_TD_NOM, POUT_TD_EX	—	-64	-60	
Spectral Emissions Margin	SEM1–SEM3	POUT = POUT_TD_NOM, Margin to ETSI SEM mask	5	—	—	dB	
Error Vector Magnitude ¹	EVM_RMS	POUT_TD_NOM	—	1	2	%	
		POUT_TD_EX	—	—	2		
Harmonic Suppression ¹	f ₀₂ –f ₀₆	POUT ≤ POUT_TD_NOM, POUT_TD_EX, RBW = 1 MHz	—	—	-36	dBm	
Tx Noise in Rx Bands ¹ DCS Rx		f _{Rx} = 1805 MHz to 1850 MHz, POUT = POUT_TD_NOM NTC RBW = 100 kHz	—	—	-81	dBm	
Input Voltage Standing Wave Ratio	VSWR_IN	NTC	—	—	2.5:1	—	
Rise / Fall Time	TonDC	TRx Mode to TDD LTE Tx, from MIPI command and >90% VRAMP to 0.5 dB RF settling	—	—	10	μs	
	ToFFDC	TDD LTE Tx to TRx Mode, from MIPI command or <10% VRAMP to 30 dB gain drop	—	—	10		
Stability	S	VSWR = 12:1 All phases, RBW = 1 MHz	—	—	-36	dBm	
Ruggedness - no damage	Ru	All phases, time = 10 seconds	20:1	—	—	VSWR	

¹ Measured using ETSI TS 125.102 UL reference measurement channel (12.2 kbps), 16% duty cycle.

Table 12. SKY77912-61 Electrical Specifications – TD-SCDMA Band 34 (2010–2025 MHz)

Unless otherwise specified: HPM (Linear GMSK/EDGE Operation); VRAMP = 1.45 V (VRAMP-based Operation); ETC per Table 2.

Parameters	Symbol	Condition	Min	Typ	Max	Unit	
Output Power	POUT_TD_NOM	NTC	24.5	—	—	dBm	
	POUT_TD_EX		23.5	—	—		
Gain	High Power	GHPM_TDLTE_NOM	POUT = POUT_TD_NOM	26.5	28.3	30.0	dB
		GHPM_EX	POUT = POUT_TD_EX	23.0	—	31.0	
	Low Power	GLPM	PIN = -35 dBm, VRAMP = 0.3 V	—	15.0	20.0	
Power Added Efficiency	PAEHPM	POUT = POUT_TD_NOM	—	13.5	—	%	
Adjacent Channel Leakage power Ratio ¹	1.6 MHz offset	ACLR1.6	POUT_TD_NOM	—	-44	-40	dBc
			POUT_TD_EX	—	—	-38	
	3.2 MHz offset	ACLR3.2	POUT_TD_NOM, POUT_TD_EX	—	-62	-58	
Spectral Emissions Margin	SEM1–SEM3	POUT = POUT_TD_NOM, Margin to ETSI SEM mask	5	—	—	dB	
Error Vector Magnitude ¹	EVM_RMS	POUT_TD_NOM	—	1	2	%	
		POUT_TD_EX	—	—	2		
Harmonic Suppression ¹	f ₀₂ –f ₀₆	POUT ≤ POUT_TD_NOM, POUT_TD_EX, RBW = 1 MHz	—	—	-36	dBm	
Tx Noise in Rx Bands ¹ DCS Rx		f _{Rx} = 1805 MHz to 1880 MHz, POUT = POUT_TD_NOM NTC, RBW = 100 kHz	—	—	-81	dBm	
Input Voltage Standing Wave Ratio	VSWR_IN	NTC	—	—	2.5:1	—	
Rise / Fall Time	TonDC	TRx Mode to TDD LTE Tx, from MIPI command and >90% VRAMP to 0.5 dB RF settling	—	—	10	μs	
	ToFFDC	TDD LTE Tx to TRx Mode, from MIPI command or <10% VRAMP to 30 dB gain drop	—	—	10		
Stability	S	VSWR = 12:1 All phases, RBW = 1 MHz	—	—	-36	dBm	
Ruggedness - no damage	Ru	All phases, time = 10 seconds	20:1	—	—	VSWR	

¹ Measured using ETSI TS 125.102 UL reference measurement channel (12.2 kbps), 16% duty cycle.

Table 13. SKY77912-61 Electrical Specifications –TDD LTE Band 39 (1880–1920 MHz)

Unless otherwise specified: HPM (Linear GMSK/EDGE Operation); VRAMP = 1.2 V (VRAMP-based Operation); ETC per Table 2.

Parameters	Symbol	Condition	Min	Typ	Max	Unit	
Output Power ¹	POUT_TDLTE_NOM	NTC	23.5	—	—	dBm	
	POUT_TDLTE_EX		22.5	—	—		
Gain ¹	High Power	GHPM_TDLTE_NOM	POUT = POUT_TDLTE_NOM	26.5	28.3	30.0	dB
		GHPM_TDLTE_EX	POUT = POUT_TDLTE_EX	24.0	—	30.5	
	Low Power	GLPM	Pin = -35 dBm, VRAMP = 0.3 V	—	15.0	20.0	
Power Added Efficiency	PAEHPM	POUT = POUT_TDLTE_NOM	—	13.5	—	%	
Low Power Mode Current	IBATT_LPM	VRAMP = 0.3 V POUT = 0 dBm NTC	—	50	—	mA	
Adjacent Channel Leakage power Ratio ¹	EUTRA_ACLR1	POUT = POUT_TDLTE_NOM	—	-42	—	dBc	
		POUT = POUT_TDLTE_EX	—	—	-36		
	UTRA_ACLR1	POUT = POUT_TDLTE_NOM	—	-45	—		
		POUT = POUT_TDLTE_EX	—	—	-39		
	UTRA_ACLR2	POUT = POUT_TDLTE_NOM	—	-48	—		
		POUT = POUT_TDLTE_EX	—	—	-42		
Spectral Emissions Margin	SEM1–SEM9	POUT = POUT_TDLTE_NOM, Margin to ETSI SEM mask	5	—	—	dB	
Error Vector Magnitude ¹	EVM_RMS	POUT = POUT_TDLTE_NOM	—	1.7	2.5	%	
		POUT = POUT_TDLTE_EX	—	—	2.5		
Harmonic Suppression ²	Second	f ₀₂	POUT ≤ POUT_TDLTE_NOM, POUT_TDLTE_EX, RBW = 1 MHz	—	—	-36	dBm
	Third			f ₀₃	—	—	
Tx Noise in Rx Bands ³	Band 34 Rx	PNOISE_TDLTE_B34	f _{Rx} = 2010 to 2025 MHz, POUT = POUT_TDLTE_NOM – MPR, NTC RBW = 100 kHz	—	—	-75	
Input Voltage Standing Wave Ratio	VSWR_IN	NTC	—	—	2.5:1	—	
Rise / Fall Time	TonDC	TRx Mode to TDD LTE Tx, from MIPI command and >90% VRAMP to 0.5 dB RF settling	—	—	10	μs	
	ToFFDC	TDD LTE Tx to TRx Mode, from MIPI command or <10% VRAMP to 30 dB gain drop	—	—	10		
Stability	S	VSWR = 12:1 All phases, RBW = 1 MHz	—	—	-36	dBm	
Ruggedness - no damage	Ru	All phases, time = 10 seconds	20:1	—	—	VSWR	

¹ Performance is measured using UL reference measurement channel, 10 MHz, QPSK, 12RB, per ETSI TS 136.101 (Release 12, section A.2.3.2.1-4a).

² Harmonic suppression is measured using UL reference measurement channel, 1.4 MHz, QPSK, 1RB, per ETSI TS 136.01 (Release 12, section A.2.3.2.1-1).

³ Noise is measured using UL reference measurement channel, 20 MHz, QPSK, 100 RB, per ETSI TS 136.101 (Release 12, section A.2.3.1.1)

Table 14-1. SKY77912-61 Electrical Specifications – TRx Ports - TRx1 to TRx10
Unless otherwise specified: any TRx Mode; ETC per Table 2.

Parameter	Symbol	Conditions	Min	Typ	Max	Unit	
Frequency Range	f_{TRx}	—	699	—	2690	MHz	
Insertion Loss	RX_IL_LB	699 MHz to 960 MHz, NTC	TRx7	—	0.55	0.70	dB
			TRx2/3/4/9/10	—	0.65	0.80	
			TRx1/5/6/8	—	0.75	0.90	
	RX_IL_MB	1710 MHz to 2400 MHz, NTC	TRx7	—	0.65	0.85	
			TRx2/3/4/9/10	—	0.90	1.20	
			TRx1/5/6/8	—	0.95	1.25	
	RX_IL_HB	2500 MHz to 2700 MHz, NTC	TRx7	—	0.80	1.05	
			TRx2/3/4/9/10	—	1.10	1.35	
			TRx1/5/6/8	—	1.25	1.60	
TRx Mode VSWR ¹	VSWR _{TRx}	NTC	—	1.5:1	—	VSWR	
Isolation	Active TRx port to any adjacent TRx port	ISO_ADJ_TRx_LB	699 MHz to 960 MHz	26.0	35.0	—	dB
		ISO_ADJ_TRx_MB	1710 MHz to 1990 MHz	23.0	30.0	—	
		ISO_ADJ_TRx_HB	2010 MHz to 2690 MHz	20.0	25.0	—	
	Active TRx port to any non-adjacent TRx port	ISO_NONADJ_TRx_LB	699 MHz to 960 MHz	33.5	40.0	—	
		ISO_NONADJ_TRx_MB	1710 MHz to 1990 MHz	27.0	35.0	—	
		ISO_NONADJ_TRx_HB	2010 MHz to 2690 MHz	24.0	30.0	—	
TRx Harmonics	TRx _{2f0} , TRx _{3f0}	NTC, 50 ohm, P _{IN_TRx} = +27 dBm	—	—	-55	dBm	
		NTC VSWR 5:1 at ANT port, P _{IN_TRx} = +27 dBm	—	—	-50		
Band 13 – 2 nd Harmonic	TRx _{2f0_B13}	P _{TRx} = 25 dBm at 787 MHz, NTC		-70		dBm	

Table 14-2. SKY77912-61 Electrical Specifications – TRx Ports - TRx1 to TRx10

Unless otherwise specified: any TRx Mode; ETC per Table 2.

Parameter	Symbol	Conditions	Min	Typ	Max	Unit
2 nd Order Intermodulation Distortion $f_{\text{IMD2}} = f_{\text{tx}} \pm f_{\text{blocker}} $	IMD2	Tx Output Power = 20 dBm CW Blocker Power = -15 dBm CW NTC	—	-102	-98	dBm
3 rd Order Intermodulation Distortion $f_{\text{IMD3}} = 2f_{\text{tx}} - f_{\text{blocker}}$	IMD3 IMD3_TRx234	TRx port duplexer termination VSWR \geq 10:1 at f_{blocker} , all phases	—	-105 -109	-102 -105	
Leakage from Tx to TRx Ports	P_TxTRx	Any TX Mode	—	—	0	dBm
Coupling Factor in TRx Mode ²	CPL_TRx_LB	699 to 960 MHz, NTC	—	-27	—	dB
	CPL_TRx_MB	1710 to 1990 MHz, NTC	—	-23	—	
	CPL_TRx_HB	2010 to 2690 MHz, NTC	—	-22	—	
Coupling Factor Variation over Output VSWR ³	CPL_SWR_TRx_LB	699 to 960 MHz, VSWR 2.5:1 at ANT port	-0.8	—	0.8	dB
	CPL_SWR_TRx_MB	1710 to 1990 MHz, VSWR 2.5:1 at ANT port	-1.0	—	1.0	
	CPL_SWR_TRx_HB	2010 to 2690 MHz, VSWR 2.5:1 at ANT port	-1.0	—	1.0	
Coupling Factor Variation over Temperature ^{3,4}	CPL_TV_TRx_LB	699 to 960 MHz	-0.5	—	0.5	dB
	CPL_TV_TRx_MB	1710 to 1990 MHz	-1.0	—	1.0	
	CPL_TV_TRx_HB	2010 to 2690 MHz	-1.0	—	1.0	
Turn-on Time	T_ON_VBATT	From 50% V _{BATT} and V _{IO} to 0.5 dB RF settling	—	—	20	μ s
TRx-to-TRx Switch Speed	T_TRxTRx	From MIPI command to 0.5 dB RF settling	—	2	5	μ s

¹ Based on the worst of TRx and ANT port reflection coefficients.

² Defined as the ratio of CPL port to ANT port output power, driven from TRx.

³ Variation with respect to 50 ohm reference.

⁴ Variation with respect to NTC.

MIPI RFFE Information

Table 15. SKY77912-61 MIPI RFFE Register Map (Linear GMSK Power Control only)

Bit Position	Description	Trigger Support	R/W	Default	Notes
Register 0, Address 0x00 (Mode Control)					
[7]	Register Map & Power Control Selector	Trigger0	R/W	0	(set to 0 to select this Linear GMSK Power Control register map)
[6:3]	PA Bias Mode Control			0000	0000 = Low Band EDGE 0100 = B34/39 TD-SCDMA 0110 = Low Band Switch OUT 0001 = High Band EDGE 0101 = B39 TDD LTE 0111 = High Band Switch OUT 0010 = Low Band GMSK 0011 = High Band GMSK
[2]	PA Enable			0	0 = PA Tx Disabled 1 = PA Tx Enabled
[1:0]	Power Range Mode			00	00 = High Power Mode (HPM) 01 = Mid Power Mode (MPM) 10 = Low Power Mode (LPM) 11 = Ultra-Low Power Mode (ULPM)
Register 1, Address 0x01 (RESERVED)					
[7:0]	RESERVED	Trigger0	R/W	00000000	RESERVED
Register 2, Address 0x02 (Switch Control)					
[7:5]	RESERVED	Trigger0	R/W	000	RESERVED
[4:0]	Switch Control			00000	0x00 = Standby 0x06 = TRx5 0x11 = TRx1 0x01 = TRx9 0x07 = TRx7 0x12 = TRx10 0x02 = TRx8 0x08 = TRx3 0x10 = TRx8 + TRx9 (UL CA) 0x03 = Forward Isolation 0x09 = Low Band PA Tx 0x13 = TRx9 + TRx10 (UL CA) 0x04 = TRx4 0x0B = High Band PA Tx 0x05 = TRx6 0x0C = TRx2 Other = Reserved (Do Not Use)
Register 3, Address 0x03 (RESERVED)					
[7:0]	RESERVED	Trigger0	R/W	00000000	RESERVED
Register 4, Address 0x04 (RESERVED)					
[7:0]	RESERVED	Trigger0	R/W	00000000	RESERVED
Register 5, Address 0x05 (RESERVED)					
[7:0]	RESERVED		R/W	00000000	RESERVED
Register 6, Address 0x06 (RESERVED)					
[7:0]	RESERVED		R/W	00000000	RESERVED

Table 16. SKY77912-61 MIPI RFFE Register Map (Vramp-based Operation only)

Bit Position	Description	Trigger Support	R/W	Default	Notes
Register 0, Address 0x00 (Mode Control)					
[7]	Register Map and Power Control Selector	Trigger0	R/W	0	(set to 1 to select this Vramp GMSK Power Control register map)
[6]	Gain Control (GMSK)			0	0 = nominal gain 1 = reduced gain
[5]	Gain Control (linear)			0	0 = nominal gain 1 = reduced gain
[4:0]	TxFEM Mode Control			00000	0x00 = Standby 0x06 = Forward Isolation 0x0E = HB GMSK/ VRAMP Tx 0x01 = TRx4 0x08 = TRx9 0x0F = HB EDGE/Linear Tx 0x02 = TRx3 0x09 = TRx6 0x14 = TRx10 0x03 = TRx2 0x0A = LB GMSK/VRAMP Tx 0x18 = TRx1 0x04 = TRx8 0x0B = LB EDGE/Linear Tx 0x10 = TRx8 + TRx9 (UL CA) 0x05 = TRx5 0x0D = TRx7 0x1C = TRx9 + TRx10 (UL CA) Other = Reserved (Do Not Use)
Register 1, Address 0x01 (Bias Control)					
[7:4]	PA Stage 3 Bias (DAC3)	Trigger0	R/W	0000	0000 = 250 μ A 0110 = 1750 μ A 1100 = 3250 μ A 0001 = 500 μ A 0111 = 2000 μ A 1101 = 3500 μ A 0010 = 750 μ A 1000 = 2250 μ A 1110 = 3750 μ A 0011 = 1000 μ A 1001 = 2500 μ A 1111 = 4000 μ A 0100 = 1250 μ A 1010 = 2750 μ A 0101 = 1500 μ A 1011 = 3000 μ A
[3:0]	PA Stage 1-2 Bias (DAC12)			0000	0000 = 250 μ A 0110 = 1750 μ A 1100 = 3250 μ A 0001 = 500 μ A 0111 = 2000 μ A 1101 = 3500 μ A 0010 = 750 μ A 1000 = 2250 μ A 1110 = 3750 μ A 0011 = 1000 μ A 1001 = 2500 μ A 1111 = 4000 μ A 0100 = 1250 μ A 1010 = 2750 μ A 0101 = 1500 μ A 1011 = 3000 μ A
Register 2, Address 0x02 (RESERVED)					
[7:0]	RESERVED	Trigger0	R/W	00000000	RESERVED
Register 3, Address 0x03 (RESERVED)					
[7:0]	RESERVED	Trigger0	R/W	00000000	RESERVED
Register 4, Address 0x04 (RESERVED)					
[7:0]	RESERVED	Trigger0	R/W	00000000	RESERVED
Register 5, Address 0x05 (RESERVED)					
[7:0]	RESERVED		R/W	00000000	RESERVED
Register 6, Address 0x06 (RESERVED)					
[7:0]	RESERVED		R/W	00000000	RESERVED

Table 17-1. SKY77912-61 MIPI RFFE Register Map (Common Registers)

Bit Position	Description	Trigger Support	R/W	Default Value	Notes
Register 26, Address 0x1A (RFFE Status)					
7	SOFTWARE RESET	No	R/W	0	Reset all configurable registers to default values except for USID, GROUP_SID, and PM_TRIG. The RFFE_STATUS register shall reset after it is read. SOFTWARE RESET always reads back as zero. 0 = normal operation 1 = software reset.
6	COMMAND_FRAME_PARITY_ERR			0	Command Sequence received with parity error – discard command. The RFFE_STATUS register shall reset after it is read.
5	COMMAND_LENGTH_ERR			0	Command length error. The RFFE_STATUS register shall reset after it is read.
4	ADDRESS_FRAME_PARITY_ERR			0	Address frame with parity error. The RFFE_STATUS register shall reset after it is read.
3	DATA_FRAME_PARITY_ERR			0	Data frame with parity error. The RFFE_STATUS register shall reset after it is read.
2	READ_UNUSED_REG			0	Read command to an invalid address. The RFFE_STATUS register shall reset after it is read.
1	WRITE_UNUSED_REG			0	Write command to an invalid address. The RFFE_STATUS register shall reset after it is read.
0	BID_GID_ERR			0	Read command with a BROADCAST_ID or GROUP_ID. The RFFE_STATUS register shall reset after it is read.
Register 27, Address 0x1B (GROUP_ID)					
7:4	(Reserved)	No	R/W	0000	(Reserved)
3:0	Group SID			0000	Group slave ID
Register 28, Address 0x1C (PM_TRIG)					
7:6	PWR_MODE (See Note)	No	R/W	00	00 = Normal Operation (ACTIVE) 01 = Default Settings 10 = Low Power (LOW POWER) 11 = Reserved
5	Trigger Mask 2			0	Trigger Enable: 0, Trigger Disable: 1
4	Trigger Mask 1			0	Trigger Enable: 0, Trigger Disable: 1
3	Trigger Mask 0			0	Trigger Enable: 0, Trigger Disable: 1
2	Trigger Register 2			0	Not supported
1	Trigger Register 1			0	Not supported
0	Trigger Register 0			0	1 = Latch Register contents

Table 17-2. SKY77912-61 MIPI RFFE Register Map (Common Registers)

Bit Position	Description	Trigger Support	R/W	Default Value	Notes
Register 29, Address 0x1D (PROD_ID)					
7:0	Product ID	No	R	0x9D	Product ID
Register 30, Address 0x1E (MAN_ID)					
7:0	Manufacturer ID	No	R	0xA5	Manufacturer ID [7:0]
Register 31, Address 0x1F (USID)					
7:6	(Reserved)	No	R/W	00	(Reserved)
5:4	Manufacturer ID (MSB)		R	01	Manufacturer ID [9:8]
3:0	User ID			1110	USID
Register 32, Address 0x20 (EXT_PRODUCT_ID)					
7:0	EXT_PROD_ID	No	R	0x00	
Register 35, Address 0x23 (UDR_RST)					
7	SOFTWARE RESET	No	R/W	0	1 = Reset (see Register 26)
6:0	(Reserved)	No	R/W	0000000	Reserved. Set to zero.

NOTE: When an RFFE Slave is initially powered up and comes out of reset, it enters Low Power Mode. During Low Power Mode, all Slave registers shall be set to their default settings.

Technical Information

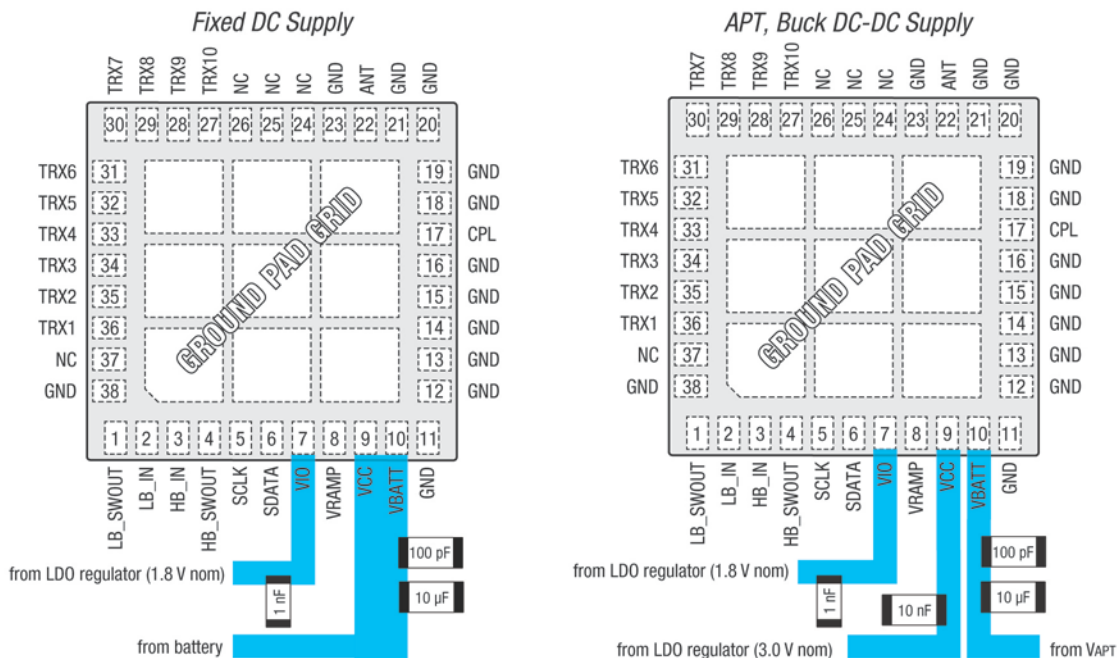

Figure 2. SKY77912-61 Application Schematics

203954_003

Package Dimensions

The SKY77912-61 quad-band front-end module is a 5.5 mm x 5.3 mm x 0.71 mm, 38-pad, leadless package. Figure 3 is a three-view mechanical drawing of the pad configuration with layout

dimensions. Figure 4 provides a recommended phone board layout footprint for the FEM to help the designer attain optimum thermal conductivity, good grounding, and minimum RF discontinuity for the 50-ohm terminals.

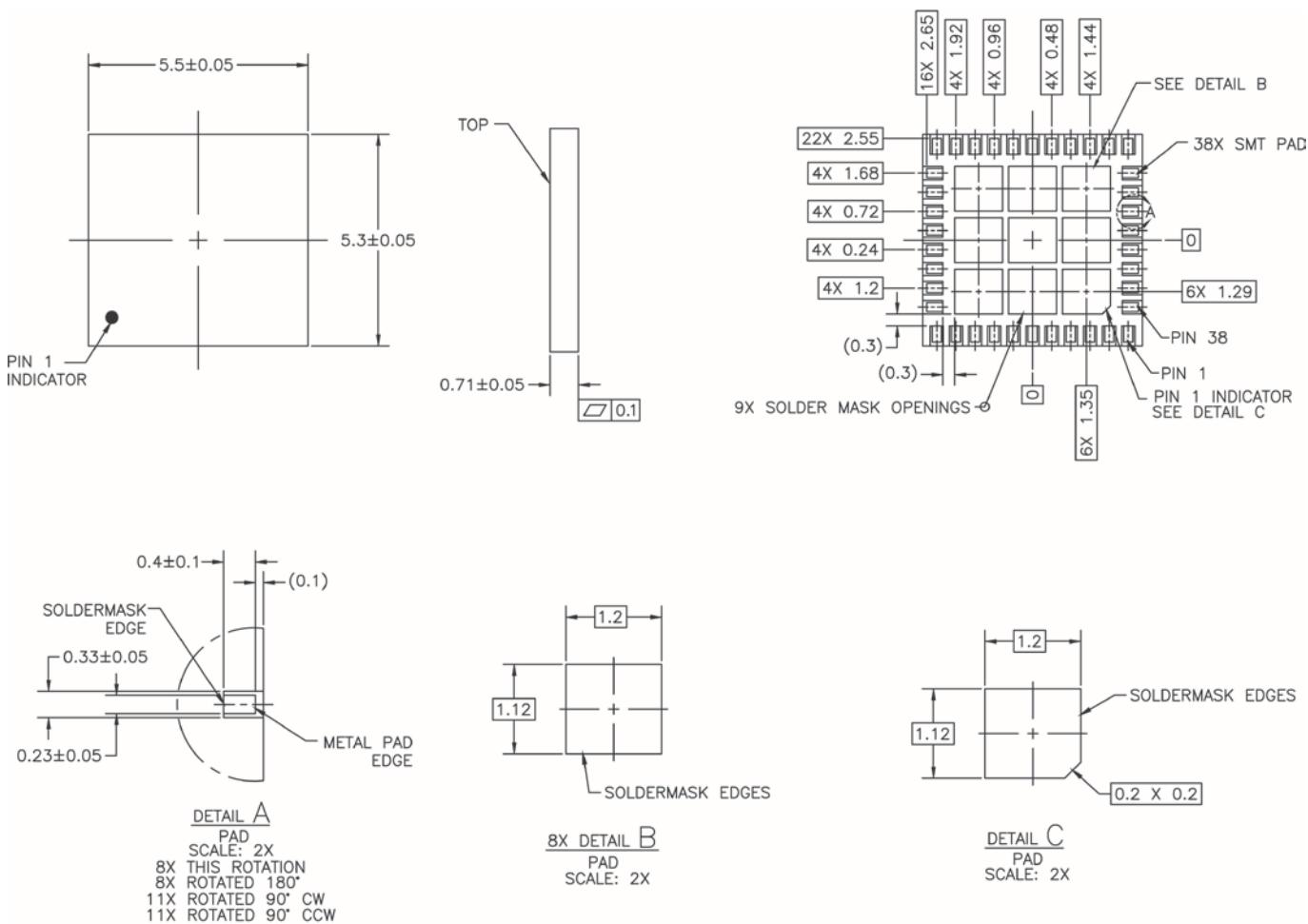

NOTES: UNLESS OTHERWISE SPECIFIED.

1. DIMENSIONING AND TOLERANCING IN ACCORDANCE WITH ASME Y14.5M-1994.
2. DIMENSIONS ARE IN MILLIMETERS
3. PAD DEFINITIONS PER DETAILS ON DRAWING.
4. DWG REFLECTS CUSTOMER REQUESTED DIMENSIONING.

05-0014_77912-61 REV 2 08/16/17 2008A_001

Figure 3. Dimensional Diagram for 5.5 mm x 5.3 mm x 0.71 mm, 38-Pad Leadless Package – SKY77912-61 (All Views)

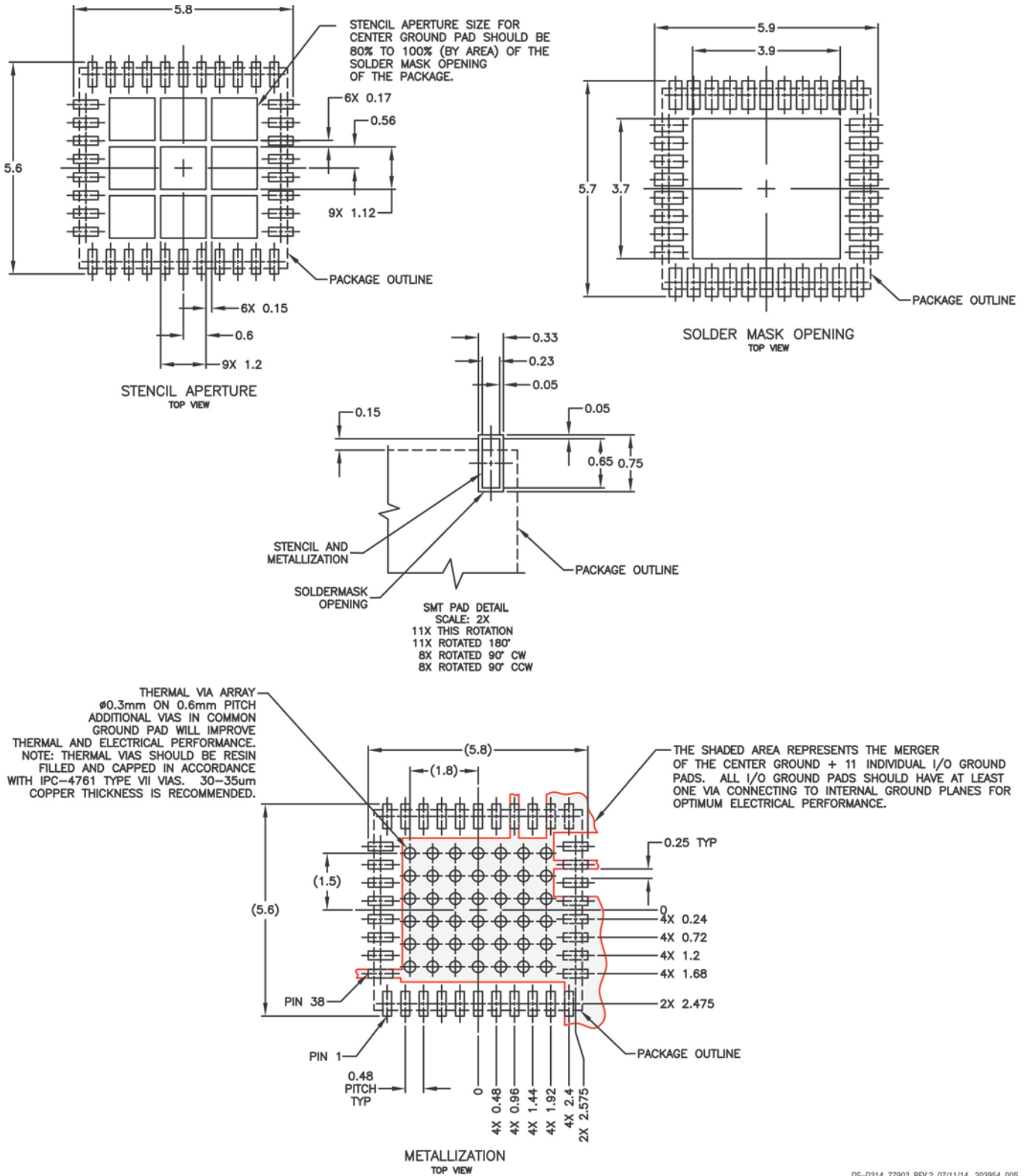
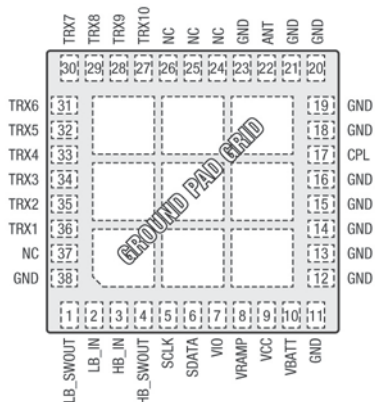

Figure 4. PCB Layout for 5.5 mm x 5.3 mm, 38-Pad Leadless Package – SKY77912-61 Specific

Package Description

Figure 5 shows the device pad configuration and the pad numbering convention, which starts with pad 1 in the lower left and increments counter-clockwise around the package. Table 18 lists the pad names and signal descriptions. Figure 6 illustrates the typical case markings.



Pad layout as seen from Top View looking through package.

203954_006

Figure 5. SKY77912-61 Pad Names and Configuration (Top View)

Package Handling Information

Because of its sensitivity to moisture absorption, this device package is baked and vacuum-packed prior to shipment. Instructions on the shipping container label must be followed regarding exposure to moisture after the container seal is broken, otherwise, problems relate to moisture absorption may occur when the part is subjected to high temperature during solder assembly.

The SKY77912-61 is capable of withstanding an MSL3/260 °C solder reflow. Care must be taken when attaching this product, whether it is done manually or in a production solder reflow environment. If the part is attached in a reflow oven, the temperature ramp rate should not exceed 3 °C per second; maximum temperature should not exceed 260 °C. If the part is manually attached, precaution should be taken to insure that the part is not subjected to temperatures exceeding 260 °C for more than 10 seconds. For details on attachment techniques, precautions, and handling procedures recommended by Skyworks, please refer to Skyworks Application Note: *PCB Design and SMT Assembly/Rework*, Document Number 101752. Additional information on standard SMT reflow profiles can also be found in the *JEDEC Standard J-STD-020*.

Production quantities of this product are shipped in the standard tape-and-reel format (Figure 7).

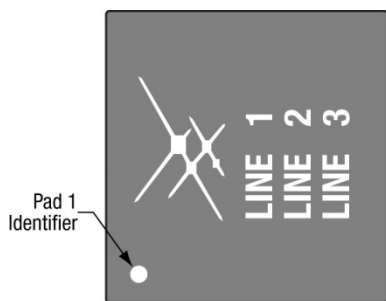

NOTE: Lines 1, 2, 3 have a maximum of 12 characters
 Line 1 = Part Number and Version
 Line 2 = Lot Number
 Line 3 = YEAR–WEEK–Country Code (MX)

203954_007

Figure 6. Typical Case Markings

Table 18. SKY77912-61 Pad Descriptions and Functions

Pad ¹	Name	Description
1	LB_SWOUT	Alternate RF output path for LB_IN
2	LB_IN	RF input to LB PA or LB_SWOUT
3	HB_IN	RF input to HB PA or HB_SWOUT
4	HB_SWOUT	Alternate RF output path for HB_IN
5	SCLK	MIPI clock
6	SDATA	MIPI serial data
7	VIO	MIPI supply voltage
8	VRAMP	Controls GMSK power; EDGE, TD-SCDMA, TDD LTE bias
9	VCC	Output switch supply voltage
10	VBATT	PA supply voltage
17	CPL	Directional coupler RF output
22	ANT	RF output to antenna
24–26	NC	No connection
27–36	TRx10–TRx1	Wideband TRx switch ports
37	NC	No connection
Ground Pad Grid		Ground Pad Grid (device underside)

¹ Pads 11–16, 18–21, 23, and 38 are ground pads.

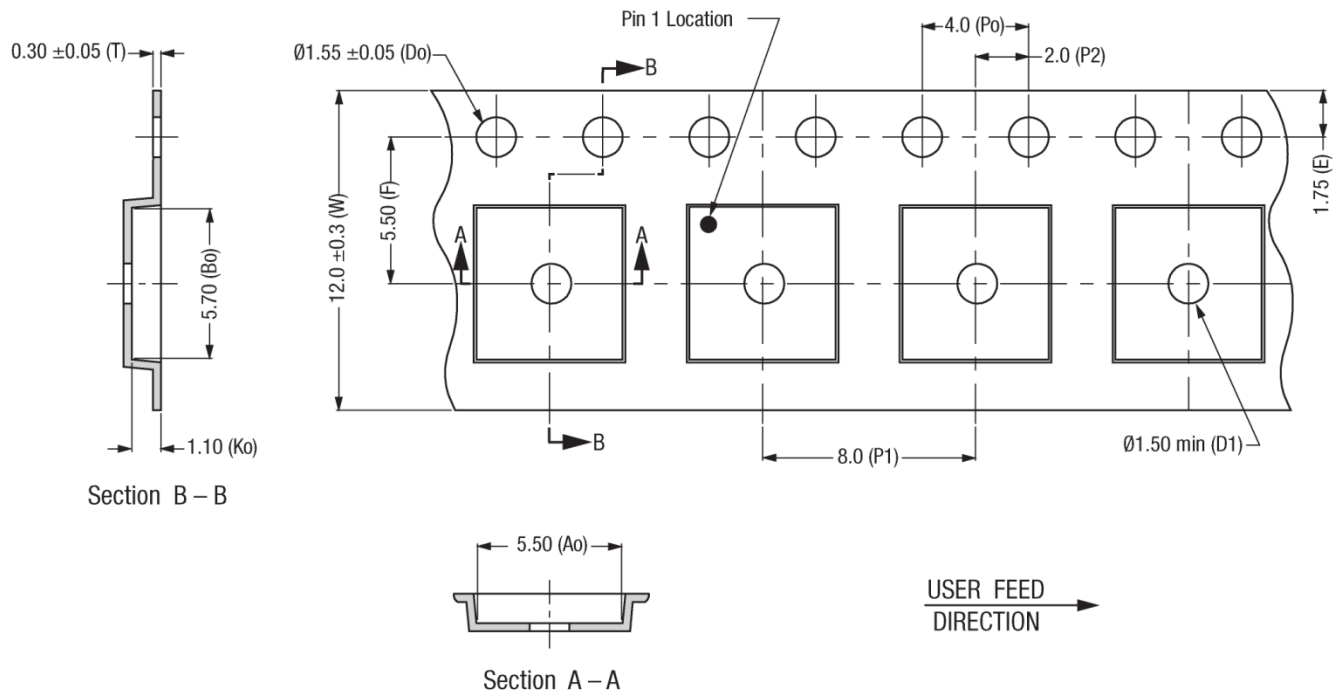

NOTES:

1. CARRIER TAPE IS BLACK CONDUCTIVE POLYSTYRENE OR POLYCARBONATE.
2. COVER TAPE IS TRANSPARENT AND CONDUCTIVE.
3. ESD SURFACE RESISTIVITY 10^4 TO 10^{11} OHMS/SQ, PER EIA, JEDEC TAPE AND REEL SPEC.
4. Po/P1 10 PITCHES CUMULATIVE TOLERANCE ON TAPE: ± 0.20 mm.
5. Ao & Bo MEASUREMENT POINT TO BE 0.3 mm FROM BOTTOM POCKET.
6. ALLOWABLE CAMBER TO BE 1/100 mm, NON-CUMULATIVE OVER 250 mm.
7. ALL DIMENSIONS ARE IN MILLIMETERS.

Carrier Tape for Body Size 5.3 x 5.5 x 0.80-1.10 mm D232-078D

Figure 7. Dimensional Diagram for Carrier Tape Body Size 5.3 mm x 5.5 mm x 0.85-1.10 mm – MCM

Electrostatic Discharge (ESD) Sensitivity



Attention: Observe Precautions for Handling Electrostatic-Sensitive Devices. Electrostatic Discharge (ESD) can damage this device, which must be protected from ESD at all times. Static charges may easily produce potentials of several kilovolts on the human body or equipment which can discharge without detection. Industry-standard ESD precautions should be used at all times.

To avoid ESD damage, both latent and visible, it is very important that the product assembly and test areas follow the ESD handling precautions listed below

- Personnel Grounding
 - Wrist Straps
 - Conductive Smocks, Gloves and Finger Cots
 - Antistatic ID Badges
- Protective Workstation
 - Dissipative Table Top
 - Protective Test Equipment (Properly Grounded)
 - Grounded Tip Soldering Irons
 - Solder Conductive Suckers
 - Static Sensors
- Facility
 - Relative Humidity Control and Air Ionizers
 - Dissipative Floors (less than 1,000 MΩ to GND)
- Protective Packaging and Transportation
 - Bags and Pouches (Faraday Shield)
 - Protective Tote Boxes (Conductive Static Shielding)
 - Protective Trays
 - Grounded Carts
 - Protective Work Order Holders

Ordering Information

Product Name	Order Number	Evaluation Board Part Number
SKY77912-61 Tx-Rx Front-End Module	SKY77912-61	

Revision History

Revision	Date	Description	
A	April 1, 2016	Initial Release – Preliminary Information	CN 8829
B	June 2, 2016	Revise: Features list (p1) Bullet (Carrier Aggregation statement); Figures 2, 5; Table 18 corrected issue date in Footers.	CN 9622
C	May 19, 2017	Revise: Tables 6, 7, 9, 10, 14	CN 15784
D	September 9, 2017	Revise: Figure 3	CN 16844

References

Skyworks Application Note: *PCB Design and SMT Assembly/Rework Guidelines for MCM–L Packages*; Document Number 101752

Standard SMT Reflow Profiles: *JEDEC Standard J–STD–020*

© 2016, 2017, Skyworks Solutions, Inc. All Rights Reserved.

Information in this document is provided in connection with Skyworks Solutions, Inc. (“Skyworks”) products or services. These materials, including the information contained herein, are provided by Skyworks as a service to its customers and may be used for informational purposes only by the customer. Skyworks assumes no responsibility for errors or omissions in these materials or the information contained herein. Skyworks may change its documentation, products, services, specifications or product descriptions at any time, without notice. Skyworks makes no commitment to update the materials or information and shall have no responsibility whatsoever for conflicts, incompatibilities, or other difficulties arising from any future changes.

No license, whether express, implied, by estoppel or otherwise, is granted to any intellectual property rights by this document. Skyworks assumes no liability for any materials, products or information provided hereunder, including the sale, distribution, reproduction or use of Skyworks products, information or materials, except as may be provided in Skyworks Terms and Conditions of Sale.

THE MATERIALS, PRODUCTS AND INFORMATION ARE PROVIDED “AS IS” WITHOUT WARRANTY OF ANY KIND, WHETHER EXPRESS, IMPLIED, STATUTORY, OR OTHERWISE, INCLUDING FITNESS FOR A PARTICULAR PURPOSE OR USE, MERCHANTABILITY, PERFORMANCE, QUALITY OR NON-INFRINGEMENT OF ANY INTELLECTUAL PROPERTY RIGHT; ALL SUCH WARRANTIES ARE HEREBY EXPRESSLY DISCLAIMED. SKYWORKS DOES NOT WARRANT THE ACCURACY OR COMPLETENESS OF THE INFORMATION, TEXT, GRAPHICS OR OTHER ITEMS CONTAINED WITHIN THESE MATERIALS. SKYWORKS SHALL NOT BE LIABLE FOR ANY DAMAGES, INCLUDING BUT NOT LIMITED TO ANY SPECIAL, INDIRECT, INCIDENTAL, STATUTORY, OR CONSEQUENTIAL DAMAGES, INCLUDING WITHOUT LIMITATION, LOST REVENUES OR LOST PROFITS THAT MAY RESULT FROM THE USE OF THE MATERIALS OR INFORMATION, WHETHER OR NOT THE RECIPIENT OF MATERIALS HAS BEEN ADVISED OF THE POSSIBILITY OF SUCH DAMAGE.

Skyworks products are not intended for use in medical, lifesaving or life-sustaining applications, or other equipment in which the failure of the Skyworks products could lead to personal injury, death, physical or environmental damage. Skyworks customers using or selling Skyworks products for use in such applications do so at their own risk and agree to fully indemnify Skyworks for any damages resulting from such improper use or sale.

Customers are responsible for their products and applications using Skyworks products, which may deviate from published specifications as a result of design defects, errors, or operation of products outside of published parameters or design specifications. Customers should include design and operating safeguards to minimize these and other risks. Skyworks assumes no liability for applications assistance, customer product design, or damage to any equipment resulting from the use of Skyworks products outside of stated published specifications or parameters.

Skyworks and the Skyworks symbol are trademarks or registered trademarks of Skyworks Solutions, Inc., in the United States and other countries. Third-party brands and names are for identification purposes only, and are the property of their respective owners. Additional information, including relevant terms and conditions, posted at www.skyworksin.com, are incorporated by reference.