

客户 (Customer) : _____

承认书

Approval Sheet

谨致执事者：兹提供敝公司之有关详细规格及图面数据，敬请给予办理试认定手续。

同时敬请送返一份附有贵公司签认之测试认定后之样品承认书。

We are pleased in sending you herewith on specification and drawings for your approval.

Please return to us one copy "Approval sheet" with your approved signature.

型号 (Model No.) : A-SC880IR3C-P03-1T

发文日期 (Issue Date) : 2020/09/09 承认日期 (Approved Date) : _____

Checking signature of Amicc

Designer	Checker	Approver
Darren		

Approval signature of customer

Designer	Checker	Approver

江苏欧密格光电科技股份有限公司

Jiangsu Amicc Opto-Electronics Technology Co.,Ltd.

地址：江苏省常州市武进区武南中路 98 号

Add: 98.Wu Nan Road, Wujin, Changzhou city, Jiangsu Province

TEL:0086-519-89806999

FAX:0086-519-86523668

EMAIL:AMICC@AMICC.COM

High Power Infrared Light source LED Type

A-SC880IR3C-P03-1T

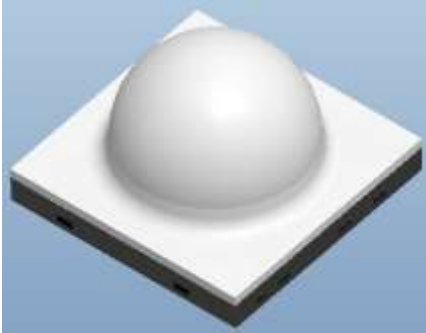

Features

- Top view LED
- Compatible with infrared and vapor phase reflow solder process.
- Narrow viewing angle --- 90°
- Pb-free
- RoHS compliant

Description

The Amicc 880 package has high efficacy, high power consumption, wide viewing angle and a compact form factor. These features make this package an ideal LED for all lighting applications.

Applications

- Infrared remote control units with high power requirement
- Smoke detector
- Infrared applied system
- Infrared illumination for cameras
- Surveillance systems

Device Selection Guide

Chip Materials	Emitted Color	Resin Color
Si-substrate	Infrared	Water clear

Absolute Maximum Ratings (T_{Soldering}=25°C)

Parameter	Symbol	Rating	Unit
Forward Current	I _F	1000	mA
Peak Forward Current Pulse Width≤100μs ,Duty≤1%.	I _{FP}	1200	mA
Reverse Voltage	V _R	5	V
Operating Temperature	T _{opr}	-40 ~ +85	°C
Storage Temperature	T _{stg}	-40 ~ +100	°C
Power Dissipation at(or below) 25°C Free Air Temperature	P _d	2.3	W
Electrostatic Discharge(HBM)	ESD	2000	V
Thermal Resistance(junction to case)	R _s	18	°C/W
Soldering Temperature	T _{sol}	260°C	°C

Electro-Optical Characteristics (T_{Soldering}=25°C)

Parameter	Symbol	Min.	Typ.	Max.	Unit	Condition
Radiant Intensity	I _e	285	380	450	mW/sr	I _F =1A, t _p =10ms
Forward Voltage	V _F	1.7	1.95	2.3	V	I _F =1A, t _p =10ms
Peak Wavelength	λ _p	-----	855	-----	nm	I _F =1A, t _p =10ms
Centroid Wavelength	λ _{centroid}	-----	850	-----	nm	I _F =1A, t _p =10ms
Spectral Half-width	Δλ	-----	25	-----	nm	I _F =1A, t _p =10ms
Viewing Angle	2θ _{1/2}	-----	90	-----	deg	I _F =350mA
Dimensions of active chip area	L x W(Typ.)		35*35			mil
Reverse Current	I _R	-----	-----	5	μA	V _R =10V

Notes:

- 1.Tolerance of Radiant Intensity: ±10%
- 2.Tolerance of Forward Voltage: ± 0.1V.

Typical Electro-Optical Characteristics Curves

Fig.1-Forward Current vs. Ambient Temperature

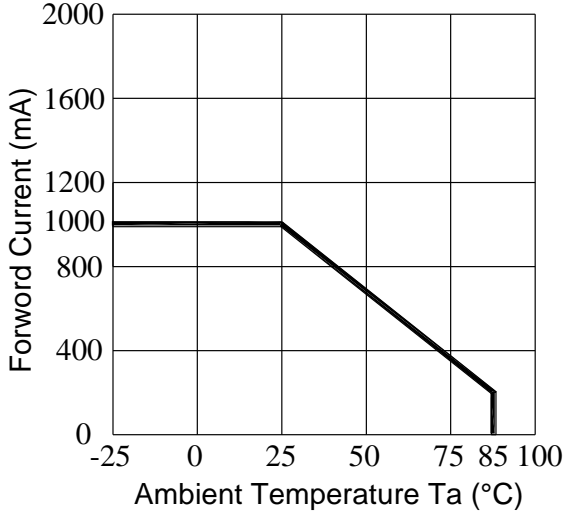

Fig.2-Spectral Sensitivity

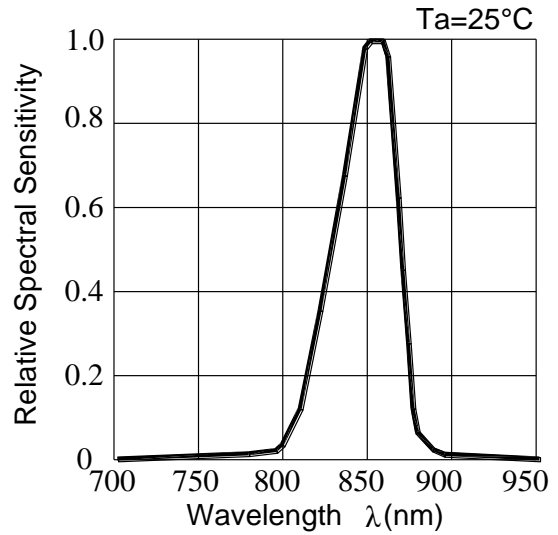

Fig.3-Forward Current vs. Forward Voltage $T_a=25^\circ\text{C}$

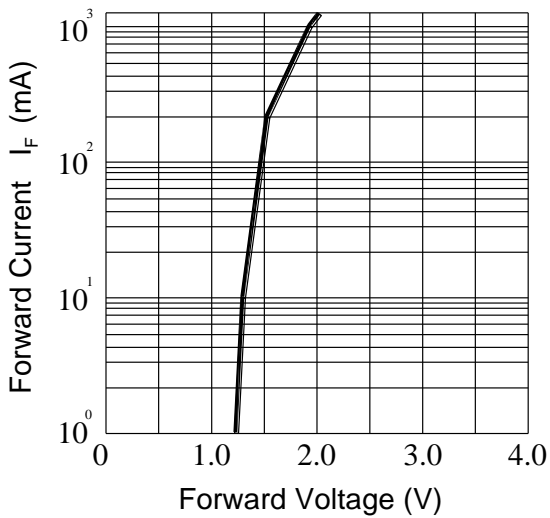
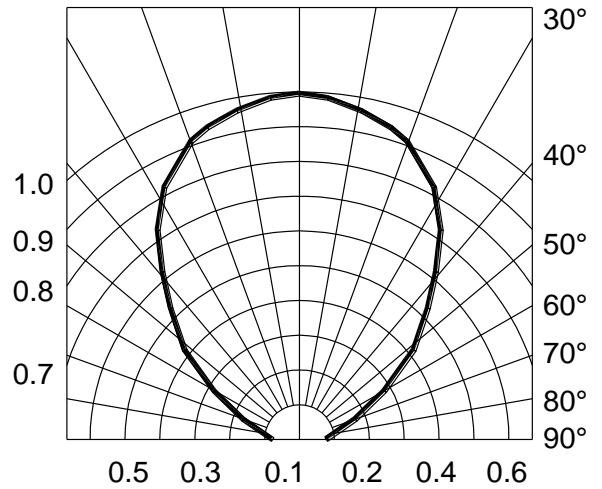

Fig.4-Radiation Diagram $T_a=25^\circ\text{C}$



Typical Electro-Optical Characteristics Curves

Fig.5-Peak Emission Wavelength vs. Ambient Temperature

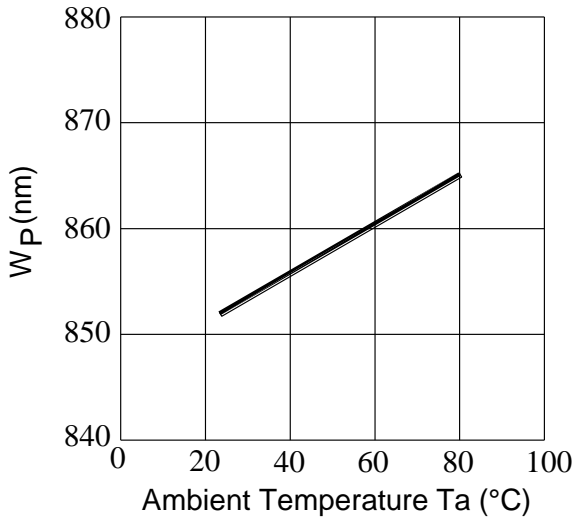

Fig.6-Relative Intensity vs. Forward Current

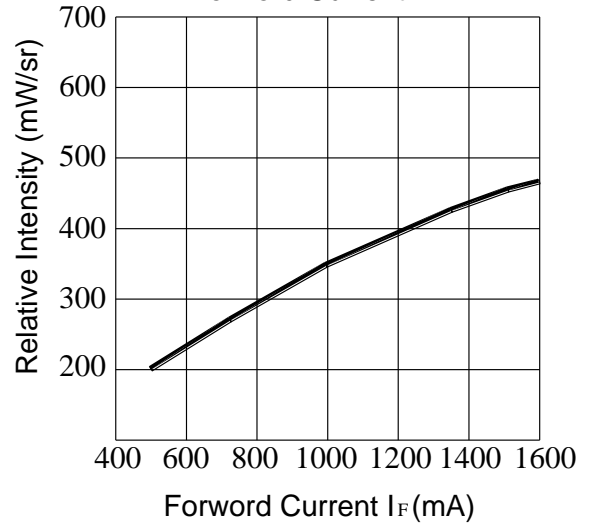

Fig.7-Relative Intensity vs. Ambient Temperature $T_a=25^\circ\text{C}$

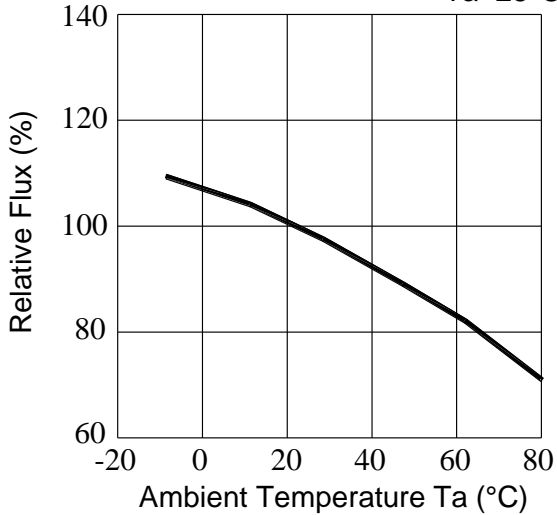
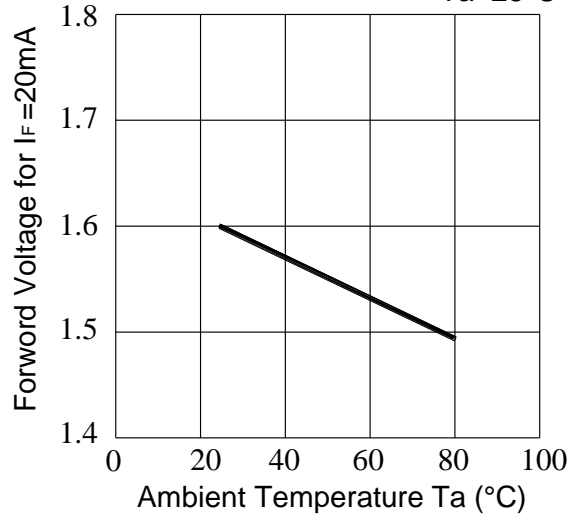
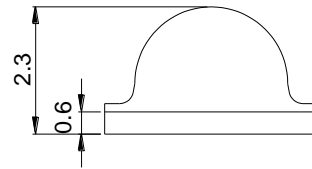
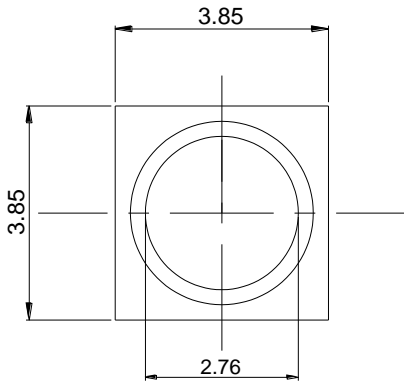

Fig.8-Forward Voltage vs. Ambient Temperature $T_a=25^\circ\text{C}$



Package Dimensions



Recommended Solder Pad

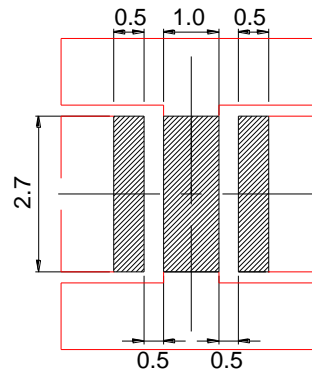
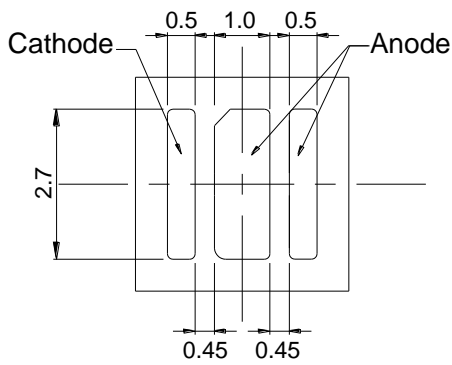

Note:
Tolerance unless mentioned is $\pm 0.25\text{mm}$, Unit = mm.

Moisture Resistant Packing Materials

Label Explanation

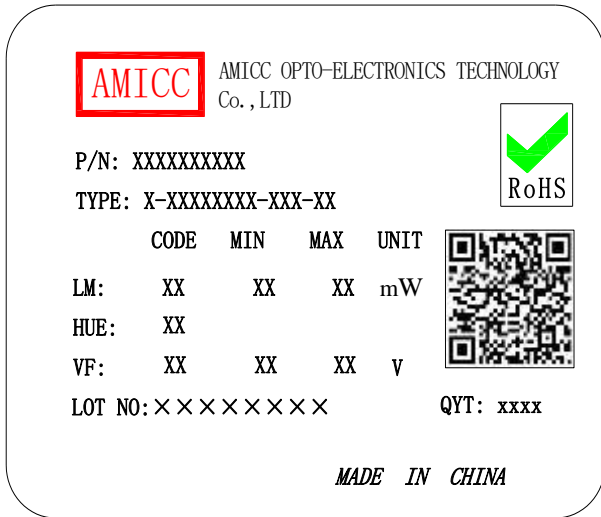

- CPN: Customer's Product Number
- P/N: Product Number
- TYPE: Part NO.
- IV: Radiant Intensity Rank
- WD: Dom. Wavelength Rank
- VF: Forward Voltage Rank
- LOT No: Lot Number
- QTY: Packing Quantity

Carrier Tape Dimensions: Loaded Quantity 1000 pcs Per Reel

Moisture Resistant Packing Process

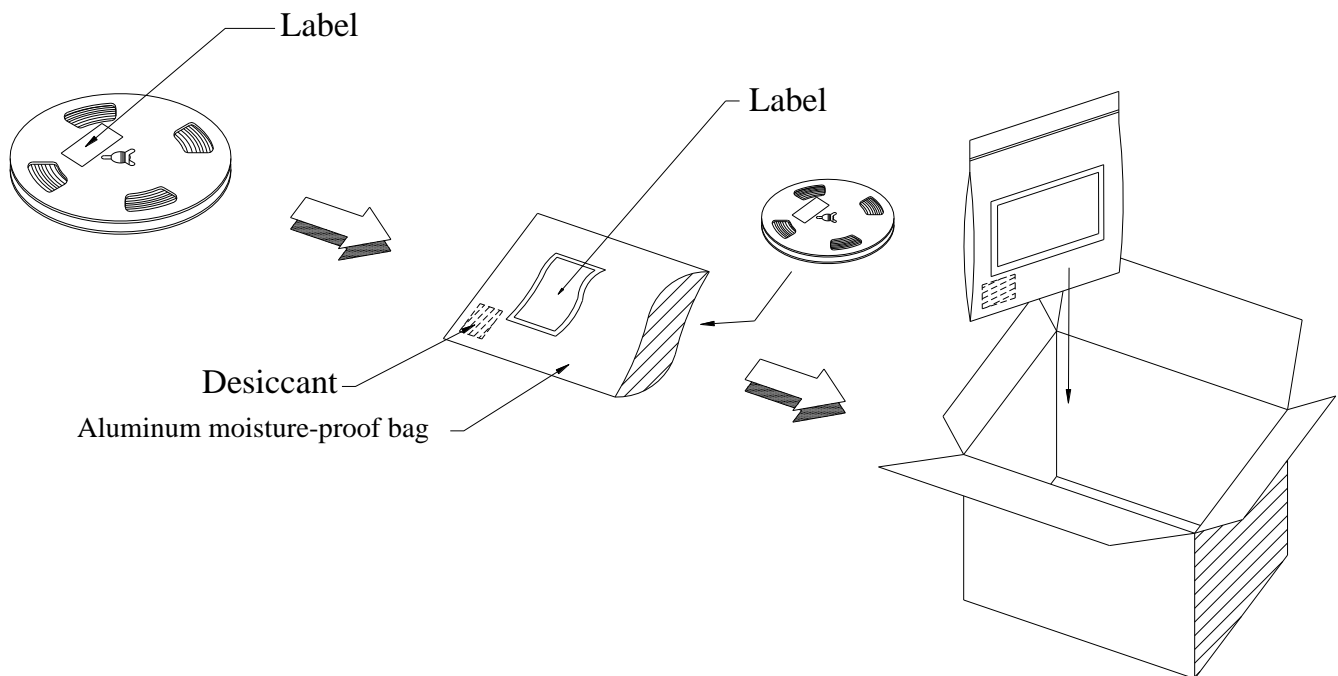

Reliability Test Items and Conditions

The reliability of products shall be satisfied with items listed below.

Confidence level : 90%

LTPD : 10%

No.	Items	Test Condition	Test Hours/Cycles	Sample Size	Ac/Re
1	Reflow Soldering	Temp. : 260°C/10sec.	3 Cycles	22 PCS.	0/1
2	Thermal Shock	H : +100°C 5min ∫ 10 sec L : -10°C 5min	100 Cycles	22 PCS.	0/1
3	Temperature Cycle	H : +100°C 15min ∫ 5 min L : -40°C 15min	100 Cycles	22 PCS.	0/1
4	High Temperature/Humidity	Ta=85°C,85%RH	1000 Hrs.	22 PCS.	0/1
5	Low Temperature Storage	Ta=-40°C	1000 Hrs.	22 PCS.	0/1
6	High Temperature Storage	Ta=100°C	1000 Hrs.	22 PCS.	0/1
7	DC Operation Life	Ts=25°C, I _F = 1A	1000 Hrs.	22 PCS.	0/1

Note:

All reliability items are tested under good thermal management with 1.0 x 1.0 cm² MCPCB

Precautions for use

1. Over-current-proof

Customer must apply resistors for protection; otherwise slight voltage shift will cause big current change (Burn out will happen).

2. Storage

2.1 Do not open moisture proof bag before the products are ready to use.

2.2 Before opening the package: The LEDs should be kept at 30°C or less and 90%RH or less.

2.3 After opening the package: The LED's floor life is 168 Hrs under 30°C or less and 60% RH or less. If unused LEDs remain, it should be stored in moisture proof packages.

2.4 If the moisture absorbent material (silica gel) has faded away or the LEDs have exceeded the storage time, baking treatment should be performed using the following conditions.

Baking treatment: 60±5°C for 24 hours.

3. Soldering Condition

3.1 Pb-free solder temperature profile

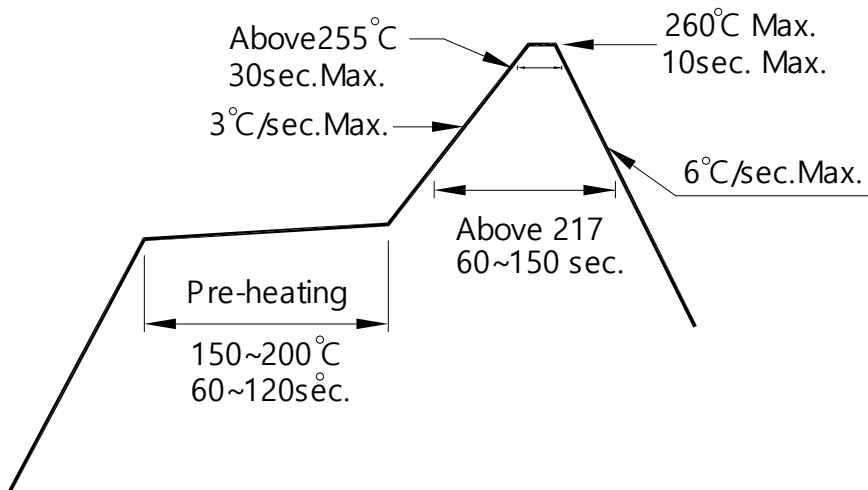

3.2 Reflow soldering should not be done more than two times.

3.3 When soldering, do not put stress on the LEDs during heating.

3.4 After soldering, do not warp the circuit board.

4. Soldering Iron

Each terminal is to go to the tip of soldering iron temperature less than 350°C for 3 seconds within once in less than the soldering iron capacity 25W. Leave two seconds and more intervals, and do soldering of each terminal. Be careful because the damage of the product is often started at the time of the hand solder.

5. Repairing

Repair should not be done after the LEDs have been soldered. When repairing is unavoidable, a double-head soldering iron should be used (as below figure). It should be confirmed beforehand whether the characteristics of the LEDs will or will not be damaged by repairing.