

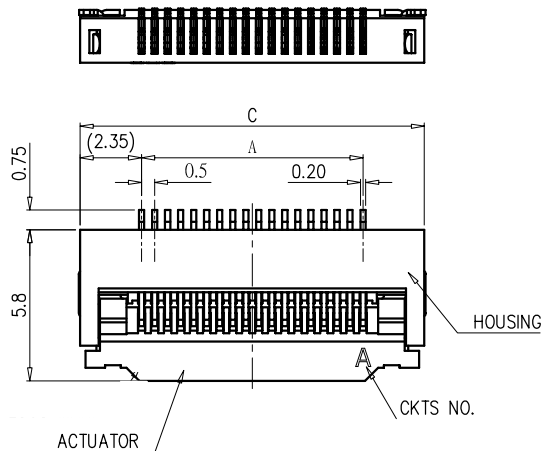

CUSTOMER

REV. 版本	MODIFICATION. 变更内容	DRAWN/DATE 设计/日期
A0	初版发行	
B	增加视图	ALLEN/2014.08.08



 Solder Area
 No Pattern Area

Electrical

Voltage: 50 V AC(rms)/DC
 Current: 0.5 A AC(rms)/DC
 Contact Resistance: 40 mΩ max(initial)
 Dielectric Withstanding Voltage: 200 V AC/rms
 Insulation Resistance: 500 MΩ min
 Operating Temp: -40° C ~ +85° C

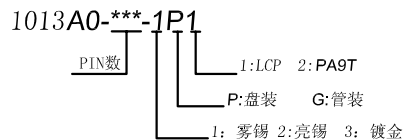

CKT	Dim A	Dim B	Dim C	CKT	Dim A	Dim B	Dim C
004	1.50	2.56	6.2	033	16.00	17.06	20.7
005	2.00	3.06	6.7	034	16.50	17.56	21.2
006	2.50	3.56	7.2	035	17.00	18.06	21.7
007	3.00	4.06	7.7	036	17.50	18.56	22.2
008	3.50	4.56	8.2	037	18.00	19.06	22.7
009	4.00	5.06	8.7	038	18.50	19.56	23.2
010	4.50	5.56	9.2	039	19.00	20.06	23.7
011	5.00	6.06	9.7	040	19.50	20.56	24.2
012	5.50	6.56	10.2	041	20.00	21.06	24.7
013	6.00	7.06	10.7	042	20.50	21.56	25.2
014	6.50	7.56	11.2	043	21.00	22.06	25.7
015	7.00	8.06	11.7	044	21.50	22.56	26.2
016	7.50	8.56	12.2	045	22.00	23.06	26.7
017	8.00	9.06	12.7	046	22.50	23.56	27.2
018	8.50	9.56	13.2	047	23.00	24.06	27.7
019	9.00	10.06	13.7	048	23.50	24.56	28.2
020	9.50	10.56	14.2	049	24.00	25.06	28.7
021	10.00	11.06	14.7	050	24.50	25.56	29.2
022	10.50	11.56	15.2	051	25.00	26.06	29.7
023	11.00	12.06	15.7	052	25.50	26.56	30.2
024	11.50	12.56	16.2	053	26.00	27.06	30.7
025	12.00	13.06	16.7	054	26.50	27.56	31.2
026	12.50	13.56	17.2	055	27.00	28.06	31.7
027	13.00	14.06	17.7	056	27.50	28.56	32.2
028	13.50	14.56	18.2	057	28.00	29.06	32.7
029	14.00	15.06	18.7	058	28.50	29.56	33.2
030	14.50	15.56	19.2	059	29.00	30.06	33.7
031	15.00	16.06	19.7	060	29.50	30.56	34.2
032	15.50	16.56	20.2				

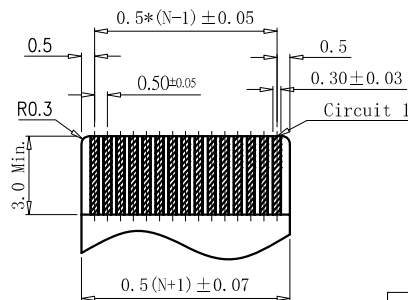
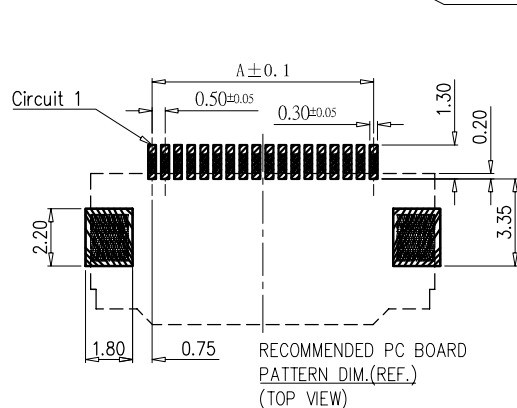
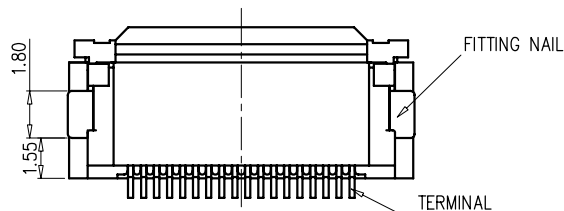
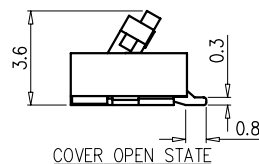
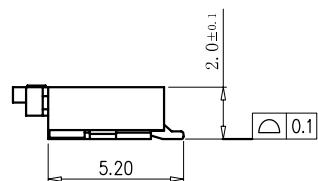
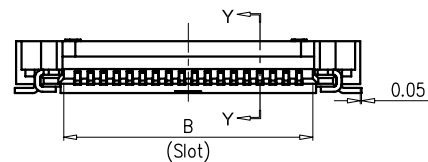

GENERAL TOLERANCE	ANGLE TOLERANCE	DESIGN. 设计	ALLEN
X. ±0.30	X' ±5.0°	2014.08.08	
.X ±0.25	.X' ±3.0°	CHECKED. 审核	
.XX ±0.15	.XX' ±2.0°	APPROVED. 核准	
.XXX ±0.10			
UNIT:mm	SCALE 1:1	FILE NAME. 品名	
A4	SHEET:1of1	PART NUMBER. 料号	
		MDRAWING NO. 图号	

FILE NAME. 品名	FPC 0.5PITCH 2.0H 掀盖式
PART NUMBER. 料号	1013A0-***-***
MDRAWING NO. 图号	1013A0
	REV. B