

Preliminary Technical Specification

Product: X75 Active Matrix Display Module (132x176)
 Siemens Part No.: V24851-Z1508-A130
 SAP Material No.: A5B00075486125
 SAP MPN No.:

Manufacturer: Alps
 Manufacturer Part No.: LPU4CG031B

Accompanying documents:

Drawing LCD Panel FPG4CG011-A DIS:
 Drawing Light Guide NFB010910B DIS:
 Drawing Display Module Assembled LPU4CG031B DIS:
 Specification LCD-Controller SSD1286

SN 72500 Part 1 (General technical terms of delivery)
 SN 29065 Part 8
 ETSI EN 301 489 – 1; - 7; - 25 (EMI/ESD)
 ISO 13406-2 (Flat panel display requirements)

				DATE: 16-12-2004	Technical Specification Aries display LPU4CG031B (ALPS Part No)	
				Daniel Homes		
0.2	130241	19.05.2005	Nozaki	COM MD PD HW2 KLF3		
0.1	130241	16.12.2004	Hom			
<u>VERS.</u>	<u>DIS</u>	<u>DATE</u>	<u>NAME</u>	SIEMENS AG		Page 1
FUNCTIONAL STATUS: ALPS						of 48

Table of Content

- 1. **General Description**.....5
 - 1.1. *Display Module*.....5
 - 1.2. *Mechanical Characteristics*.....5
 - 1.3. *General Specification*6
 - 1.3.1. Component Life Cycle.....6
 - 1.3.2. Temperature Ranges6
 - 1.3.3. Relative Air Humidity/Temperature Under Operation6
- 2. **Optical Specification**.....6
 - 2.4. *Measurement Conditions*6
 - 2.4.1. General Measurement Conditions.....6
 - 2.4.2. Viewing Angles7
 - 2.4.3. Siemens Optical Measurement Equipment7
 - 2.4.4. Supplier Optical Measurement Equipment9
 - 2.4.5. Measuring Points10
 - 2.5. *Optical Characteristics*.....11
 - 2.5.1. Contrast.....11
 - 2.5.2. Contrast Over Viewing Angle And Temperature12
 - 2.5.3. Spatial Contrast Variation.....13
 - 2.5.4. Colour14
 - 2.5.5. Colour Uniformity Versus Viewing Angle.....18
 - 2.5.6. Spatial Colour And Brightness Uniformity, mean luminance20
 - 2.5.7. Image-Dependent Colour Variation/Crosstalk21
 - 2.5.8. Reflectance, Transmittance.....22
 - 2.5.9. Response Times23
 - 2.5.10. Cosmetic Defects24
 - 2.5.11. Pixel Faults25
- 3. **Electrical Characteristics**26
 - 3.4.1. Display Controller26
 - 3.4.1.1. Hardware-Settings26
 - 3.4.1.2. Software-Settings.....26
 - 3.4.1.3. Gradation Palette (Gamma Correction)30
 - 3.4.2. DC Characteristics31
 - 3.4.2.1. Test Pattern31
 - 3.4.3. Interface32
- 4. **Mechanical Specification**.....34
 - 4.4.1. Draft technical drawing34
 - 4.4.2. Interface Contact Pad.....34
 - 4.4.3. FPC to Panel Interconnection Peel Off Profile Test34
 - 4.4.4. Module Assembly On Siemens PCB35
 - 4.4.5. ITO Corrosion Protection36
 - 4.4.6. Dangerous Substances (according SN36350 Part 2)36
 - 4.4.7. Tensile Strength (EN 843-1 or JIS for ceramic bending measurement)36
 - 4.4.8. Chipped glass edges (of LCD-panel).....37
- 5. **Climatic- And Environmental Tests As Performed by Siemens**.....38
 - 5.1. *Test Standard Conditions*38
 - 5.2. *Mechanical Stress Tests*.....38
 - 5.2.1. Mechanical Test Series38
 - 5.2.2. Vibration With Temperature.....39
 - 5.3. *Climatic Stress Tests*.....39
 - 5.3.1. Climatic Test Sequence.....39

				DATE: 16-12-2004	Technical Specification Aries display LPU4CG031B (ALPS Part No)	
				Daniel Homes		
0.2	130241	19.05.2005	Nozaki	COM MD PD HW2 KLF3		
0.1	130241	16.12.2004	Hom			
<u>VERS.</u>	<u>DIS</u>	<u>DATE</u>	<u>NAME</u>	SIEMENS AG		Page 3
FUNCTIONAL STATUS: ALPS						of 48

5.3.2.	Dry Heat.....	40
5.3.3.	Temperature Change (shock).....	40
5.3.4.	Damp Heat Cycle.....	41
5.3.5.	Constant Cold.....	41
5.3.6.	Temperature Change With Gradient.....	42
5.3.7.	Heat With Solar Radiation.....	42
5.4.	<i>Aging</i>	43
5.4.1.	Mixed Gases And Vibration.....	43
5.4.2.	Vibration At Extreme Temperatures.....	43
5.4.3.	Aging By Temperature.....	44
5.4.4.	Aging By Damp Heat Constant.....	44
5.4.5.	Mixed Gases And Damp Heat (Cyclic).....	44
5.5.	<i>Other Tests</i>	45
5.5.1.	ESD.....	45
5.5.2.	Ambient Light Sensitivity.....	45
5.5.3.	Resistance to EMI.....	45
6.	Packaging And Handling Items.....	46
6.4.	<i>Protection Foil Panel</i>	46
6.5.	<i>Package</i>	46
6.6.	<i>Module And Package Labelling</i>	47
6.6.1.	Module Labelling.....	47
6.6.2.	Product Package Labelling.....	47
6.6.3.	Barcode label on product packaging (Packing for mechanical components).....	47
	<i>Criteria And Procedures For Acceptance</i>	48
6.7.	<i>Acceptance Of Technical Specification</i>	48

				DATE: 16-12-2004	Technical Specification Aries display LPU4CG031B (ALPS Part No)	
				Daniel Homes		
0.2	130241	19.05.2005	Nozaki	COM MD PD HW2 KLF3		
0.1	130241	16.12.2004	Hom			
<u>VERS.</u>	<u>DIS</u>	<u>DATE</u>	<u>NAME</u>	SIEMENS AG		Page 4
FUNCTIONAL STATUS: ALPS						of 48
Aries 132x176 1.8 TFT Alps TTD V1						

1. General Description

1.1. Display Module

This specification describes a display module with an intelligent graphic Liquid Crystal Display (LCD). The specification comprises

- an Active Matrix Liquid Crystal Display Panel, transfective, 1.8", 132x176 dots, 262k colours, positive mode
- a display controller mounted on the display glass (COG) which is connected to a FPC inside the module
- and a light guide with 4 white LED's according Stanley colour ranking "Colour Ranking 2d"
- Illumination foil stack is implemented in the module to hint the specified brightness and homogeneity
- A PCB/FPC with all passive components.
- A plastic frame
- Full contrast adjusted
- An electrical interface that consists of land pattern designed for spring connector. The spring connector is mounted on the Siemens PCB
- Serial and parallel interface
- Mechanical design and delivery concept supports automatic and half automatic display assembly at Siemens production line

1.2. Mechanical Characteristics

Display Module:

Outline dimensions 35.50x 52.0 x 3.5 mm³ (W x H x T)
 Weight 8.7 g (complete module)

Display Panel:

Display Resolution 132 x 176 pixel
 Dot Pitch horizontal: 0.21 mm
 vertical: 0.21 mm

Active Display Area 27.72 x 36.96 mm² (W x H)
 Blackmatrix area 32.3 x 40,0 mm² (W x H)
 Outline Dimensions panel 32.3 x 47.1 mm² (W x H)
 Design Viewing Direction 6 o'clock display

				DATE: 16-12-2004	Technical Specification Aries display LPU4CG031B (ALPS Part No)	
				Daniel Homes		
0.2	130241	19.05.2005	Nozaki	COM MD PD HW2 KLF3		
0.1	130241	16.12.2004	Hom			
<u>VERS.</u>	<u>DIS</u>	<u>DATE</u>	<u>NAME</u>	SIEMENS AG		Page 5
FUNCTIONAL STATUS: ALPS						of 48

1.3. General Specification

1.3.1. Component Life Cycle

Storage Life	min. 1 Year
Operation Life *1	min. 40 x 10 ³ h (22h per day x 7 days per week x 52 weeks / year x 5 years)
Backlight Operation Life *2	min. 5 x 10 ³ h
MTBF, MTTF, DPM	as defined in QAA
Storage and Operation Life Times are defined for a temperature of +25°C	

Notes:

*1. Operation life ends when one of the listed faults occurs:

- The on/off response-times reach 1.5 times of the max. value specified for a new display
- The contrast is reduced to 0.5 of the typ. value specified for a new display
- Loss of function
- The number of cosmetic defects and pixel faults exceeds the maximum defined

*2. Backlight Operation Life ends when the backlight luminance is reduced to 0.7 of the original value

1.3.2. Temperature Ranges

Storage Temperature	-30 ... +80	°C
Reduced Function	-25 ... +65	°C
Operating Temperature	-20 ... +55	°C

1.3.3. Relative Air Humidity/Temperature Under Operation

Temperature	40°C ± 2°C
Relative Humidity	93% ± 2%
Time	500h

2. Optical Specification

2.4. Measurement Conditions

2.4.1. General Measurement Conditions

Unless specified, the following test conditions are valid:

Room Temperature	23 (+/-4)	°C
Air Pressure	70 ... 110	kPa
Relative Humidity	10 ... 85	%RH
Hard- and Software-Settings	as specified in chapter 3.4.1	
Main Viewing Angle	Θ=Φ=0°	

				DATE: 16-12-2004	Technical Specification Aries display	
				Daniel Homes		
0.2	130241	19.05.2005	Nozaki	COM MD PD HW2 KLF3		
0.1	130241	16.12.2004	Hom		LPU4CG031B (ALPS Part No)	
<u>VERS.</u>	<u>DIS</u>	<u>DATE</u>	<u>NAME</u>	SIEMENS AG		Page 6
FUNCTIONAL STATUS: ALPS						of 48
Aries 132x176 1.8 TFT Alps TTD V1						

2.4.2. Viewing Angles

Azimuth Angle : Φ
 Tilt Angle : Θ

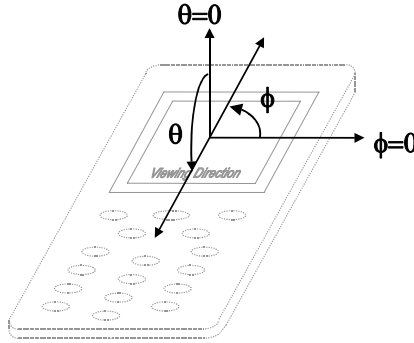

2.4.3. Siemens Optical Measurement Equipment

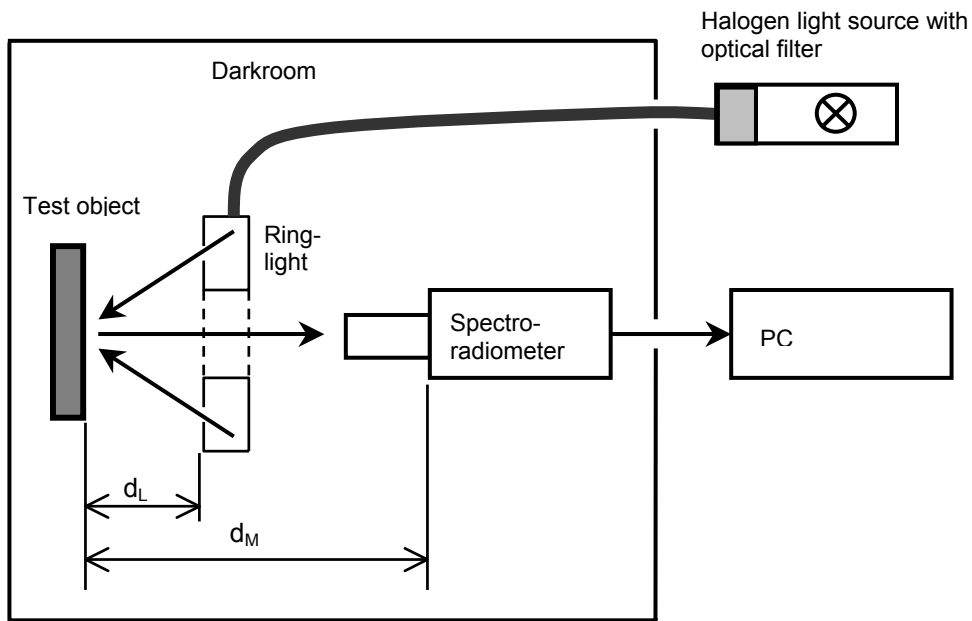

Specification

Spectroradiometer	Minolta CS-1000
Objective	Standard (50mm, f:1.4), Macro (50mm, f:2.8)
Ring light optical diameter	80mm
Reflectance Standard	Gigahertz Optik BN-0201-01 (calibrated)
White light source	Halogen Ring Light with optical daylight filter. Diameter=80mm. Light source equivalent Type C (colour temperature=6774K)

Measuring Distance d_M [mm]	155	225	450
Lighting Distance d_L [mm]	55	125	350
Objective type	Macro	Macro	Standard
Measuring point diameter [mm]	1.15	3	8

				DATE: 16-12-2004	Technical Specification Aries display LPU4CG031B (ALPS Part No)	Page <u>7</u> of 48
				Daniel Homes		
0.2	130241	19.05.2005	Nozaki	COM MD PD HW2 KLF3		
0.1	130241	16.12.2004	Hom			
<u>VERS.</u>	<u>DIS</u>	<u>DATE</u>	<u>NAME</u>	SIEMENS AG		
FUNCTIONAL STATUS: ALPS						

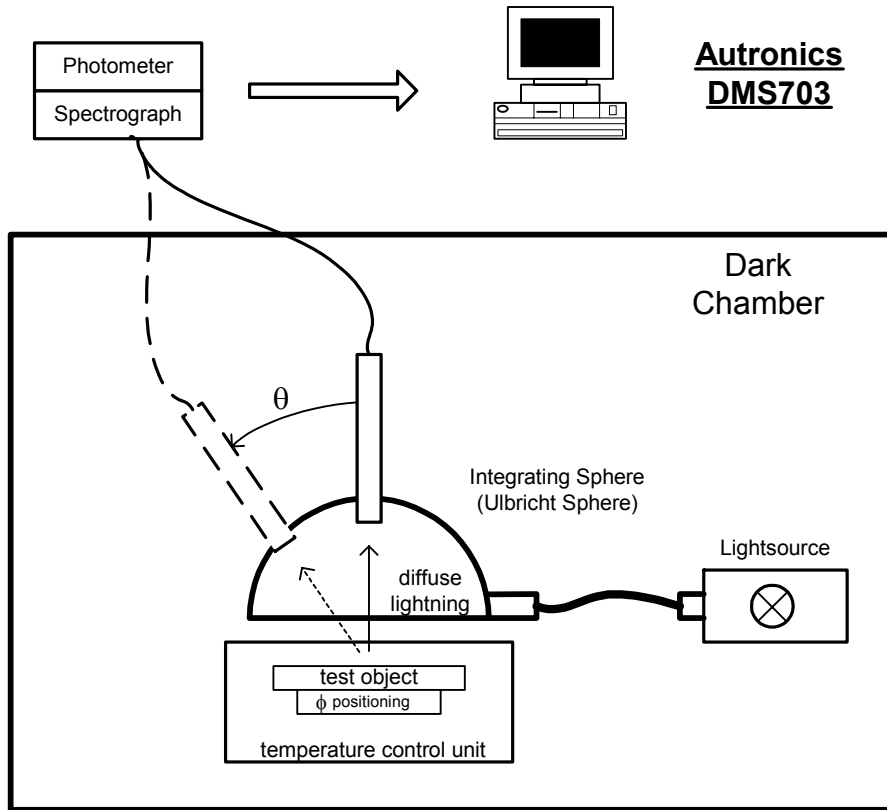

Specification Autronic DMS703:

Spectrograph
 Photometer
 Temperature Control
 Reflectance Standard (Cal.plate)
 Lightsource

CCD Spect2
 PT100
 HSC-3 (air-forced temp. control, temp.range from -35°C to +85°C)
 Labsphere ID SRS-99-020
 Halogen Lightsource with daylight filter
 Uniform Source Integrating Sphere (Ulbricht Sphere)

				DATE: 16-12-2004	Technical Specification Aries display LPU4CG031B (ALPS Part No)	
				Daniel Homes		
0.2	130241	19.05.2005	Nozaki	COM MD PD HW2 KLF3		
0.1	130241	16.12.2004	Hom			
<u>VERS.</u>	<u>DIS</u>	<u>DATE</u>	<u>NAME</u>	SIEMENS AG		Page 8
FUNCTIONAL STATUS: ALPS						of 48

2.4.4. Supplier Optical Measurement Equipment

ALPS Optical Measurement Equipment

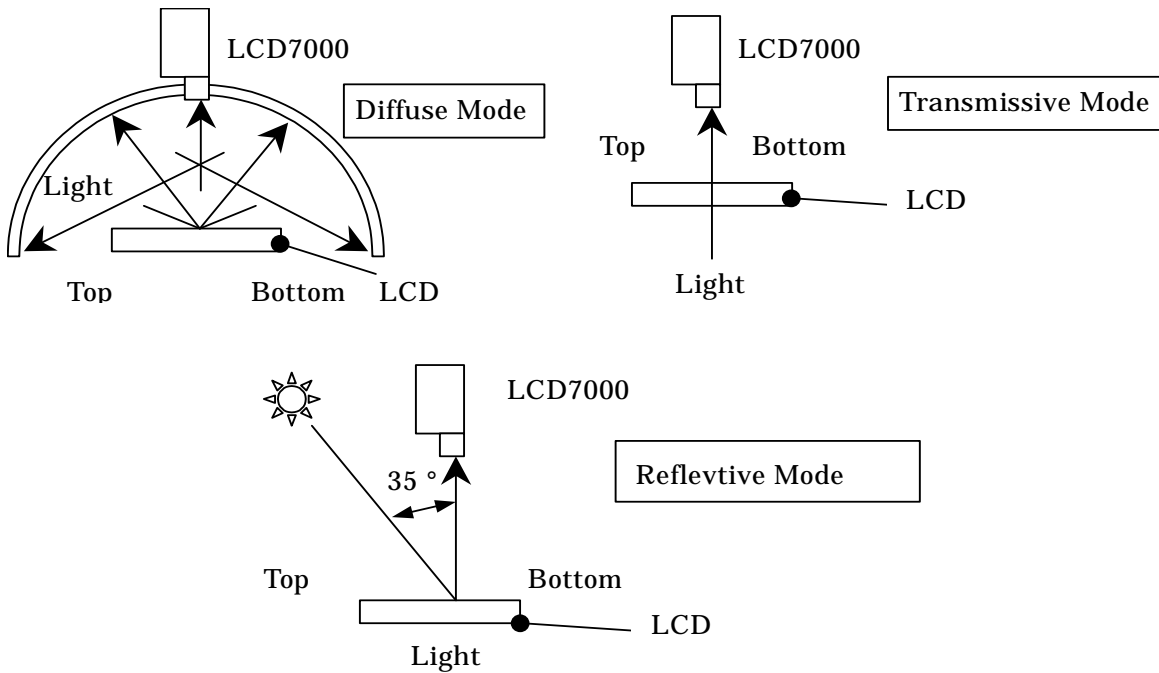

Specification Otsuka Electronics LCD-7000:

Spectrograph	MCPD-7000
Photometer	R374 (with Spectral Luminous Efficacy Compensation Filter)
Temperature Control	Tabai Espec Corp. EY-101
Reflectance Standard	Labsphere SRS-99-020
Lightsource	Halogen Lightsource
	Uniform Source Integrating Sphere
Lightsource type	D65
Measurement spot diameter	4mm
Distance panel surface to hemisphere	3mm

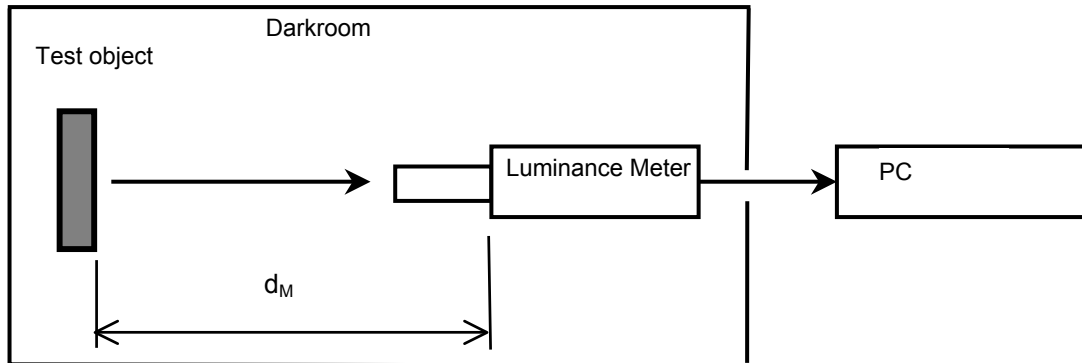

Specification

Luminance meter Topcon BM-5A

Measuring Distance d_M [mm]	500
Measurement spot diameter [mm]	1

				DATE: 16-12-2004	Technical Specification Aries display LPU4CG031B (ALPS Part No)	
				Daniel Homes		
0.2	130241	19.05.2005	Nozaki	COM MD PD HW2 KLF3		
0.1	130241	16.12.2004	Hom			
<u>VERS.</u>	<u>DIS</u>	<u>DATE</u>	<u>NAME</u>	SIEMENS AG		Page 9
FUNCTIONAL STATUS: ALPS						of 48
Aries 132x176 1.8 TFT Alps TTD V1						

2.4.5. Measuring Points

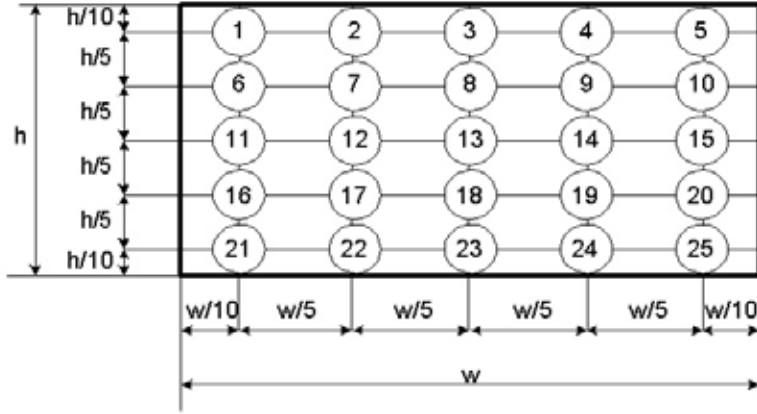

h: height of active area
w: width of active are

Luminance meter Topcon BM-5A
Measurement spot diameter 1 [mm]

				DATE: 16-12-2004	Technical Specification Aries display LPU4CG031B (ALPS Part No)	
				Daniel Homes		
0.2	130241	19.05.2005	Nozaki	COM MD PD HW2 KLF3		
0.1	130241	16.12.2004	Hom			
<u>VERS.</u>	<u>DIS</u>	<u>DATE</u>	<u>NAME</u>	SIEMENS AG		Page 10
FUNCTIONAL STATUS: ALPS						of 48

2.5. Optical Characteristics

2.5.1. Contrast

Introduction

Contrast is measured under Design Viewing Direction (perpendicular to display surface) in reflective and transmissive mode.

Measurement conditions: SUPPLIER

Measuring Equipment	Autronic DMS703 ALPS: Reflective Mode: Otsuka LCD-7000 Transmissive Mode: Topcon BM-5A Yokogawa 329802-J
Objective	Reflective Mode: 250mm Transmissive Mode: 500mm 5mm(329802-J)
Measuring Distance d_M	Reflective Mode: 250mm Transmissive Mode: 500mm
Measurement Point Diameter	3mm ALPS: 4mm
Measurement Point Location	Active Area center point (No. 13)
Light Source	Reflective Mode: Integrating Sphere (see 2.4.4.) Transmissive Mode: Internal (Backlight)
Lighting Distance d_L	
Test pattern	A: All_px_white B: All_px_black
Contrast setting	Maximum

Definitions

Contrast ratio (according ISO/FDIS 13406-2)

$$CR = L_A/L_B$$

where

L_A : Luminance measured with test pattern A

L_B : Luminance measured with test pattern B

Characteristics

Item	Symbol	Condition	Rating		
			Min.	Typ.	Max
Contrast Ratio	CR	Reflective Mode	3	5.8	-
Contrast Ratio	CR	Transmissive Mode	70	120	-

				DATE: 16-12-2004	Technical Specification Aries display LPU4CG031B (ALPS Part No)	
				Daniel Homes		
0.2	130241	19.05.2005	Nozaki	COM MD PD HW2 KLF3		
0.1	130241	16.12.2004	Hom			
<u>VERS.</u>	<u>DIS</u>	<u>DATE</u>	<u>NAME</u>	SIEMENS AG		
FUNCTIONAL STATUS: ALPS						Page 11 of 48

2.5.2. Contrast Over Viewing Angle And Temperature

Measurement conditions:

Measuring Equipment	Autronic DMS703 ALPS: Otsuka LCD-7000
Measuring Distance d _M	250mm
Measurement Point Diameter	4mm
Measurement Point Location	Active Area center point (No. 13)
Light Source	Reflective Mode: Integrating Sphere (see 2.4.4.) Transmissive Mode: Internal (Backlight)
Test pattern	A: All_px_white B: All_px_black

Definitions

Contrast ratio (according ISO/FDIS 13406-2)

$$CR = L_A/L_B$$

where

L_A: Luminance measured with test pattern A

L_B: Luminance measured with test pattern B

Characteristics

Contrast Ratio in reflective mode:

Θ	Φ	Contrast Ratio (reflective)					
		-20°C		25°C		55°C	
		Min.	Typ.	Min.	Typ.	Min.	Typ.
0°	0°	2.4	3.0	3.0	5.8	3.5	5.0
20°	0°	-	3.0	-	5.0	-	4.1
	90°	-	2.8	-	4.5	-	3.8
	180°	-	2.8	-	4.5	-	3.8
	270°	-	2.5	-	4.0	-	3.2
40°	0°	-	2.2	-	3.0	-	2.7
	90°	-	2.0	-	2.7	-	2.5
	180°	-	2.0	-	2.7	-	2.5
	270°	-	1.8	-	2.5	-	2.2

				DATE: 16-12-2004	Technical Specification Aries display LPU4CG031B (ALPS Part No)	
				Daniel Homes		
0.2	130241	19.05.2005	Nozaki	COM MD PD HW2 KLF3		
0.1	130241	16.12.2004	Hom			
<u>VERS.</u>	<u>DIS</u>	<u>DATE</u>	<u>NAME</u>	SIEMENS AG		Page 12
FUNCTIONAL STATUS: ALPS						of 48

Contrast Ratio in transmissive mode:

Θ	Φ	Contrast Ratio (transmissive)					
		-20°C		25°C		55°C	
		Min.	Typ.	Min.	Typ.	Min.	Typ.
0°	0°	9	21	70	120	18	55
20°	0°	-	10	-	100	-	27
	90°	-	70	-	90	-	25
	180°	-	9.0	-	100	-	27
	270°	-	6.0	-	100	-	45
40°	0°	-	3.3	-	90	-	10
	90°	-	9.0	-	85	-	6.0
	180°	-	2.6	-	90	-	7.0
	270°	-	2.6	-	100	-	7.0

Viewing angle:

Item	Symbol	Condition	Rating		
			Min.	Typ.	Max
Viewing angle with max. contrast (Main Viewing Direction)	Θ _{CR max}	Transmissive Mode	-3	1	4

2.5.3. Spatial Contrast Variation

Introduction

The Contrast Ratio variation inside the active area is defined as Spatial Contrast Variation

Measurement conditions:

Measuring Equipment	Autronic DMS703 ALPS: Otsuka LCD-7000
Objective	
Measurement Point Location	Number 1,3,5,11,13,15,21,23,25
Light Source	Integrating Sphere (see 2.4.4.)
Lighting Distance d _L	
Test pattern	A: All_px_white B: All_px_black

Definitions

Spatial Contrast Variation ΔCRS

$$\Delta CRS = ((CR_{max} - CR_{min}) / CR_{max}) * 100\%$$

where

$$CR_{max} = \text{MAX}(CR_i); \quad CR_{min} = \text{MIN}(CR_i);$$

CR_i is the Contrast Ratio at the defined measuring points.

Characteristics

Item	Symbol	Condition	Rating		
			Min.	Typ.	Max
Spatial Contrast Variation	ΔCRS	Reflective Mode	-	-	35%

				DATE: 16-12-2004	Technical Specification Aries display LPU4CG031B (ALPS Part No)	
				Daniel Homes		
0.2	130241	19.05.2005	Nozaki	COM MD PD HW2 KLF3		
0.1	130241	16.12.2004	Hom			
<u>VERS.</u>	<u>DIS</u>	<u>DATE</u>	<u>NAME</u>	SIEMENS AG		Page 13
FUNCTIONAL STATUS: ALPS						of 48

2.5.4. Colour

Measurement conditions:

Measuring Equipment	Autronic DMS703 ALPS: Otsuka LCD-7000 / Topcon BM-5A
Objective	
Measuring Distance d _M	Reflective Mode: 250mm Transmissive Mode: 500mm
Measurement Point Diameter	3mm ALPS: 4mm
Measurement Point Location	No.: 13
Light Source	Integrating Sphere (see 2.4.4.) Transmissive Mode: Internal (Backlight)
Lighting Distance d _L	
Test pattern	Red, Green, Blue, White: maximum colour saturation

Definitions

Panel colour coordinate according the CIE colour system (CIE 1976). In general, it is always requested to measure the X, Y and Z values.

Here u', v' and L* are according CIE 1976:

$$u' = \frac{4 \cdot X}{X + 15 \cdot Y + 3 \cdot Z}$$

$$v' = \frac{9 \cdot Y}{X + 15 \cdot Y + 3 \cdot Z}$$

$$L^* = 116 \cdot \left(\frac{Y}{Y_n} \right)^{1/3} - 16$$

				DATE: 16-12-2004	Technical Specification Aries display LPU4CG031B (ALPS Part No)	
				Daniel Homes		
0.2	130241	19.05.2005	Nozaki	COM MD PD HW2 KLF3		
0.1	130241	16.12.2004	Hom			
<u>VERS.</u>	<u>DIS</u>	<u>DATE</u>	<u>NAME</u>	SIEMENS AG		Page 14
FUNCTIONAL STATUS: ALPS						of 48

Colour distance definition (maximum allowed colour distance to specified typical colour coordinate):

$$\Delta u' v' = \sqrt{\Delta u'^2 + \Delta v'^2}$$

where:

$$\Delta u' = \text{Max} \left\{ \left| u'_{typ} - u'_{max} \right|, \left| u'_{typ} - u'_{min} \right| \right\}$$

$$\Delta v' = \text{Max} \left\{ \left| v'_{typ} - v'_{max} \right|, \left| v'_{typ} - v'_{min} \right| \right\}$$

Colour Gamut definition:

$$F = \sqrt{s(s-a)(s-b)(s-c)} * 1000$$

where

$$s = \frac{(a+b+c)}{2}$$

$$a = \sqrt{(u'_{blue} - u'_{red})^2 + (v'_{blue} - v'_{red})^2}$$

$$b = \sqrt{(u'_{blue} - u'_{green})^2 + (v'_{blue} - v'_{green})^2}$$

$$c = \sqrt{(u'_{red} - u'_{green})^2 + (v'_{red} - v'_{green})^2}$$

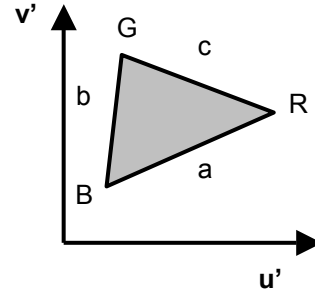

Colour Gamut definition:

$$F = \sqrt{s(s-a)(s-b)(s-c)} * 1000$$

where

$$s = \frac{(a+b+c)}{2}$$

$$a = \sqrt{(u'_{blue} - u'_{red})^2 + (v'_{blue} - v'_{red})^2}$$

$$b = \sqrt{(u'_{blue} - u'_{green})^2 + (v'_{blue} - v'_{green})^2}$$

$$c = \sqrt{(u'_{red} - u'_{green})^2 + (v'_{red} - v'_{green})^2}$$

Colour Gamut Ratio related to NTSC:

$$\text{CGR} = F(\text{Display}) / F(\text{NTSC})$$

NTSC primaries:

	u'	v'
Red	0,4769	0,5285
Green	0,0757	0,5757
Blue	0,1522	0,1957

$$F(\text{NTSC}) = 74,42$$

				DATE: 16-12-2004	Technical Specification Aries display LPU4CG031B (ALPS Part No)	
				Daniel Homes		
0.2	130241	19.05.2005	Nozaki	COM MD PD HW2 KLF3		
0.1	130241	16.12.2004	Hom			
<u>VERS.</u>	<u>DIS</u>	<u>DATE</u>	<u>NAME</u>	SIEMENS AG		Page 15
FUNCTIONAL STATUS: ALPS						of 48
Aries 132x176 1.8 TFT Alps TTD V1						

Characteristics

Mode	Item	Symbol	Min.	Typ.	Max.	Unit	
Reflective	Colour coordinate	Red	u'	-	0.284	-	
			v'	-	0.489	-	
		Green	u'	-	0.167	-	
			v'	-	0.510	-	
		Blue	u'	-	0.167	-	
			v'	-	0.388	-	
	White	u'	-	0.198	-		
		v'	-	0.473	-		
	Colour Gamut		F	3.2	7.2	11.1	
	Colour Gamut Ratio related to NSTC		CGR	4.3	9.0	-	%
Transmissive	Colour coordinate	Red	u'	-	0.390	-	
			v'	-	0.525	-	
		Green	u'	-	0.155	-	
			v'	-	0.550	-	
		Blue	u'	-	0.145	-	
			v'	-	0.250	-	
	White	u'	-	0.200	-		
		v'	-	0.460	-		
	Colour Gamut		F	30	36	-	
	Colour Gamut Ratio related to NSTC		CGR	37	48	-	%

				DATE: 16-12-2004	Technical Specification Aries display LPU4CG031B (ALPS Part No)	
				Daniel Homes		
0.2	130241	19.05.2005	Nozaki	COM MD PD HW2 KLF3		
0.1	130241	16.12.2004	Hom			
<u>VERS.</u>	<u>DIS</u>	<u>DATE</u>	<u>NAME</u>	SIEMENS AG		Page 16
FUNCTIONAL STATUS: ALPS						of 48

Colour Tolerance Table

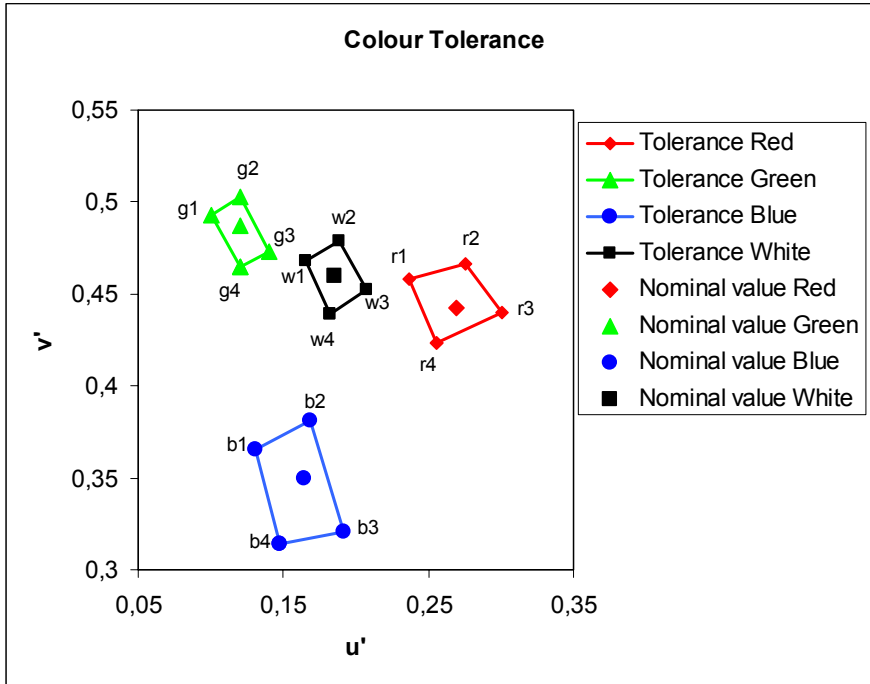

Mode	Colour	Point 1		Point 2		Point 3		Point 4	
		u'	v'	u'	v'	u'	v'	u'	v'
Reflective	Red	0.257	0.522	0.311	0.522	0.311	0.456	0.257	0.456
	Green	0.159	0.532	0.174	0.532	0.174	0.488	0.159	0.488
	Blue	0.155	0.429	0.178	0.429	0.178	0.347	0.155	0.347
	White	0.194	0.488	0.203	0.488	0.203	0.457	0.194	0.457
Transmissive	Red	0.376	0.530	0.408	0.530	0.408	0.520	0.376	0.520
	Green	0.148	0.557	0.163	0.557	0.163	0.540	0.148	0.540
	Blue	0.131	0.210	0.160	0.210	0.160	0.285	0.131	0.285
	White	0.195	0.474	0.209	0.474	0.209	0.442	0.186	0.442

Colour gamut shape

Mode	Item	Symbol	Min.	Typ.	Max	
Reflective	Colour distance	Red-Green	C	0.084	0.119	0.153
		Red-Blue	A	0.108	0.154	0.201
		Blue-Green	B	0.087	0.122	0.157
		White-Red	ΔCWR	0.060	0.087	0.120
		White-Blue	ΔCWB	0.050	0.090	0.128
		White-Green	ΔCWG	0.034	0.049	0.064
Transmissive	Colour distance	Red-Green	C	0.220	0.240	0.260
		Red-Blue	A	0.350	0.370	0.385
		Blue-Green	B	0.260	0.300	0.330
		White-Red	ΔCWR	0.185	0.200	0.215
		White-Blue	ΔCWB	0.190	0.220	0.250
		White-Green	ΔCWG	0.085	0.100	0.115

				DATE: 16-12-2004	Technical Specification Aries display LPU4CG031B ALPS Part No)	
				Daniel Homes		
0.2	130241	19.05.2005	Nozaki	COM MD PD HW2 KLF3		
0.1	130241	16.12.2004	Hom			
<u>VERS.</u>	<u>DIS</u>	<u>DATE</u>	<u>NAME</u>	SIEMENS AG		Page 17
FUNCTIONAL STATUS: ALPS						of 48

2.5.5. Colour Uniformity Versus Viewing Angle

Introduction

The display colour uniformity of each primary colour (Red, Green, Blue) should fulfil following requirements
 The reference colour (u'_{Ref} , v'_{Ref}) coordinate for any primary colour is determined in the main viewing direction.

Measurement conditions:

Measuring Equipment	Autronic DMS703 ALPS:Otsuka LCD-7000 / Topcon BM-5A
Measurement Point Diameter	3mm ALPS:4mm
Measurement Point Location	No. 13
Light Source	Integrating Sphere (see 2.4.4.) Transmissive Mode: Internal (Backlight)
Test pattern	Red, Green, Blue
Lighting Distance d_L	3 mm
Contrast setting	Maximum
Other conditions	n.a.

Definitions:

Colour distance definition:

$$\Delta u' v' = \sqrt{\Delta u'^2 + \Delta v'^2}$$

where:

$$\Delta u' = |u'_{Ref}(0^\circ, 0^\circ) - u'(\Theta, \Phi)|$$

$$\Delta v' = |v'_{Ref}(0^\circ, 0^\circ) - v'(\Theta, \Phi)|$$

Characteristics

Red:

Mode	Item	Viewing Direction		Rating				
		Θ	Φ	Min	Typ.	Max.		
Reflective	Colour Uniformity $\Delta u'v'$	0°	0°	-	0	-		
			15°	0°	-	0.052	-	
		90°		-	0.012	-		
		180°		-	0.002	-		
		270°		-	0.018	-		
		30°	0°	-	0.055	-		
			90°	-	0.029	-		
			180°	-	0.011	-		
			270°	-	0.032	-		
		Transmissive	Colour Uniformity $\Delta u'v'$	0°	0°	-	0	-
					15°	0°	-	0.011
				90°		-	0.005	0.015
180°	-			0.009		0.015		
270°	-			0.006		0.011		
30°	0°			-	0.040	0.060		
	90°			-	0.025	0.050		
	180°			-	0.038	0.060		
	270°			-	0.041	0.060		

				DATE: 16-12-2004	Technical Specification Aries display LPU4CG031B (ALPS Part No)	
				Daniel Homes		
0.2	130241	19.05.2005	Nozaki	COM MD PD HW2 KLF3		
0.1	130241	16.12.2004	Hom			
<u>VERS.</u>	<u>DIS</u>	<u>DATE</u>	<u>NAME</u>	SIEMENS AG		
FUNCTIONAL STATUS: ALPS						Page 18 of 48

Green:

Mode	Item	Viewing Direction		Rating		
		Θ	Φ	Min	Typ.	Max.
Reflective	Colour Uniformity $\Delta u'v'$	0°	0°	-	0	-
		15°	0°	-	0.030	-
			90°	-	0.006	-
			180°	-	0.002	-
			270°	-	0.009	-
		30°	0°	-	0.032	-
			90°	-	0.014	-
			180°	-	0.003	-
			270°	-	0.017	-
		Transmissive	Colour Uniformity $\Delta u'v'$	0°	0°	-
15°	0°			-	0.002	0.005
	90°			-	0.002	0.005
	180°			-	0.002	0.005
	270°			-	0.002	0.007
30°	0°			-	0.008	0.020
	90°			-	0.006	0.010
	180°			-	0.010	0.017
	270°			-	0.012	0.024

Blue:

Mode	Item	Viewing Direction		Rating		
		Θ	Φ	Min	Typ.	Max.
Reflective	Colour Uniformity $\Delta u'v'$	0°	0°	-	0	-
		15°	0°	-	0.067	-
			90°	-	0.005	-
			180°	-	0.002	-
			270°	-	0.016	-
		30°	0°	-	0.072	-
			90°	-	0.014	-
			180°	-	0.018	-
			270°	-	0.027	-
		Transmissive	Colour Uniformity $\Delta u'v'$	0°	0°	-
15°	0°			-	0.009	0.020
	90°			-	0.004	0.016
	180°			-	0.017	0.030
	270°			-	0.007	0.020
30°	0°			-	0.046	0.070
	90°			-	0.013	0.020
	180°			-	0.060	0.080
	270°			-	0.007	0.017

				DATE: 16-12-2004	Technical Specification Aries display LPU4CG031B (ALPS Part No)	
				Daniel Homes		
0.2	130241	19.05.2005	Nozaki	COM MD PD HW2 KLF3		
0.1	130241	16.12.2004	Hom			
<u>VERS.</u>	<u>DIS</u>	<u>DATE</u>	<u>NAME</u>	SIEMENS AG		Page 19
FUNCTIONAL STATUS: ALPS						of 48

2.5.6. Spatial Colour And Brightness Uniformity, mean luminance

Measurement conditions:

Measuring Equipment	Minolta / Autronic DMS703 ALPS: Otsuka LCD-7000 / Topcon BM-5A
Objective	Macro
Measuring Distance d _M	250mm / 500mm
Measurement Point Diameter	3mm ALPS: 1mm
Measurement Point Location	No.: 1 to 25
Light Source	Reflective Mode: Integrating Sphere (see 2.4.4.) Transmissive Mode: Internal (Backlight)
Lighting Distance d _L	
Test pattern	all_px_white
Contrast setting	Maximum

Definitions

Spatial Colour Uniformity:

All spatial colour variation are defined relative to the colour coordinate values in the centre of the active area (Measurement Point No. 13)

$$\Delta u'_i = u'_i - u'_{13}$$

$$\Delta v'_i = v'_i - v'_{13}$$

$$\Delta SCU = \text{Max} \sqrt{(\Delta u'_i)^2 + (\Delta v'_i)^2}$$

where

u'_i ; v'_i are the colour coordinates at measuring points 1 ... 25

Luminance variation

$$\Delta Lv_{13} = \text{Max} \left| \frac{Lv_{13} - Lv_i}{Lv_{13}} \right| * 100\%$$

where

Lv_i is the luminance at measuring points 1 ... 25

Mean Luminance on panel surface

$$Lv_{\text{mean}} = \text{AVG} (Lv_1 \dots Lv_{25})$$

where

Lv₁ ... Lv₂₅ is luminance at measuring points 1 ... 25

Characteristics

Mode	Item	Symbol	Min.	Typ.	Max.	Unit
Reflective	Spatial Colour Uniformity	ΔSCU	-	-	0.008	
Transmissive	Spatial Colour Uniformity	ΔSCU	-	-	0.009	
	Luminance variation	ΔLv ₁₃	-	-	15	%
	Mean Luminance	Lv _{mean}	140	185	-	cd/m ²

				DATE: 16-12-2004	Technical Specification Aries display LPU4CG031B (ALPS Part No)	
				Daniel Homes		
0.2	130241	19.05.2005	Nozaki	COM MD PD HW2 KLF3		
0.1	130241	16.12.2004	Hom			
<u>VERS.</u>	<u>DIS</u>	<u>DATE</u>	<u>NAME</u>	SIEMENS AG		Page 20
FUNCTIONAL STATUS: ALPS						of 48

2.5.7. Image-Dependent Colour Variation/Crosstalk

Introduction

The colour and luminance within a restricted display area can be influenced by the content of the remaining display area. Crosstalk (XT) and Image-Dependent Contrast Variation could cause this effect.

Measurement conditions:

Measuring Equipment	Minolta ALPS: Otsuka LCD-7000 / Topcon BM-5A
Objective	Macro
Measurement Point Location	No.: 13
Light Source	Reflective Mode: Integrating Sphere (see 2.4.4.) Transmissive Mode: internal (backlight)
Lighting Distance d _L	
Test pattern	See below
Contrast setting	Maximum

Test Pattern:

XT is evaluated by using midgrey (50% grey) picture with black box (1/3 of height x 1/3 of width of display area). Measurements are done in the centre of the display

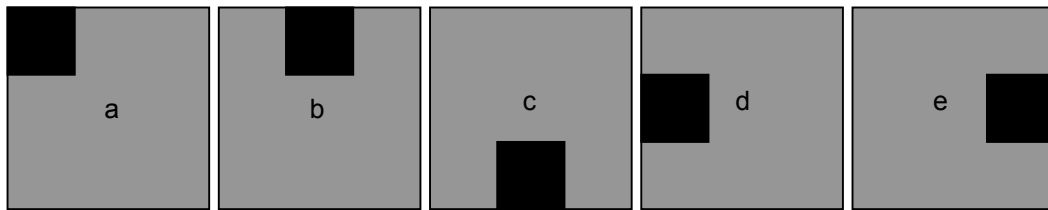

Horizontal Crosstalk:

$$HXT = \frac{\text{Max}\{|L_{13}^d - L_{13}^a|, |L_{13}^e - L_{13}^a|\}}{L_{13}^a} * 100\%$$

Vertical Crosstalk:

$$VXT = \frac{\text{Max}\{|L_{13}^b - L_{13}^a|, |L_{13}^c - L_{13}^a|\}}{L_{13}^a} * 100\%$$

L₁₃ⁱ : Luminance at measuring point 13 with bitmap I (I = a, b, c, d, e)

Crosstalk value CTV:

$$CTV = \text{Max}\{HXT, VXT\}$$

Characteristics

Item	Symbol	Condition	Rating		
			Min.	Typ.	Max
Crosstalk value	CTV	Transmissive	-	-	7.7%

OR:

Introduction

Crosstalk is an effect where the contrast of a display pixel is influenced by the state of the related pixels. **There must be no visible crosstalk judged by human eye.**

				DATE: 16-12-2004	Technical Specification Aries display	
				Daniel Homes		
0.2	130241	19.05.2005	Nozaki	COM MD PD HW2 KLF3		
0.1	130241	16.12.2004	Hom		LPU4CG031B (ALPS Part No)	
<u>VERS.</u>	<u>DIS</u>	<u>DATE</u>	<u>NAME</u>	SIEMENS AG		Page 21
FUNCTIONAL STATUS: ALPS						of 48

2.5.8. Reflectance, Transmittance

Introduction

Reflectance (diffuse reflection factor) of the LCD module is determined as factor to a standard white reference calibration plate. It is measured with the whole LCD module (including reflectance foils,...).

Transmittance (diffuse transmission factor) is a measure for the LCD panel transparency. The Light Source for this measurement is the accompanying LCD-module backlight system (LEDs, Lightguide, ...).

Measurement conditions:

Measuring Equipment	Minolta // Autronic DMS703 ALPS : Otsuka LCD-7000 / Topcon BM-5A
Objective	Macro // Standard
Measuring Distance d _M	250mm / 500mm
Measurement Point Diameter	4mm
Measurement Point Location	No.: 13
Light source	Reflectance: Integrating Sphere (see 2.4.4) Transmittance: LCD module backlight
Reflectance Plate	Reflectance Standard (Cal. plate)
Lighting Distance d _L	
Test pattern	All_Px_white
Contrast setting	Maximum

Measuring procedure:

Reflectance:

1. Measure the luminance of the Reflectance Plate
2. Replace the calibration plate with the LCD module.
Backlight: OFF.
Measure the luminance on the LCD panel surface.

Transmittance:

The light source is located at the backside of the panel.

1. Measure the light source
2. Place the LCD panel in front of the light source. Measure the luminance on the LCD panel surface

Definitions

$$R = \frac{L_{V_{LCD-Module}}}{L_{V_{ReflectancePlate}}} * 100\%$$

$$\tau = \frac{L_{V_{LCD-Panel}}}{L_{V_{LightSource}}} * 100\%$$

Characteristics

Item	Symbol	Condition	Rating		
			Min.	Typ.	Max
Reflectance factor integrating sphere	R		3.5	4.5	-
Transmittance	τ		3.5	4	-

				DATE: 16-12-2004	Technical Specification Aries display LPU4CG031B (ALPS Part No)	
				Daniel Homes		
0.2	130241	19.05.2005	Nozaki	COM MD PD HW2 KLF3		
0.1	130241	16.12.2004	Hom			
<u>VERS.</u>	<u>DIS</u>	<u>DATE</u>	<u>NAME</u>	SIEMENS AG		Page 22
FUNCTIONAL STATUS: ALPS						of 48

2.5.9. Response Times

Measurement conditions:

Measuring Equipment	Autronic DMS703 ALPS : Otsuka LCD-7000
Objective	TBD
Measuring Distance d_M	250mm
Measurement Point Diameter	3mm ALPS : 4mm
Measurement Point Location	No.: 13
Light Source	Integrating Sphere (see 2.4.4.)
Lighting Distance d_L	
Test pattern	Black, White

Definitions

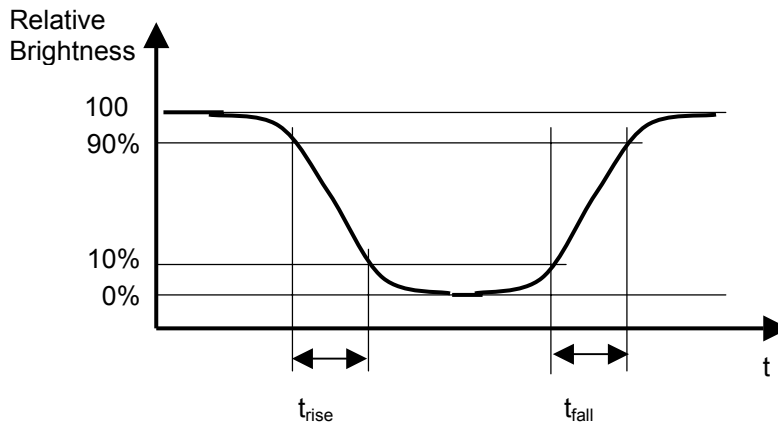

Characteristics

Item	Symbol	Temperature	Min	Typ.	Max	Units
Rise time	t_r	-20°C	-	110	200	ms
		0°C	-	16	45	ms
		+25°C	-	8	20	ms
		+55°C	-	9	20	ms
Fall time	t_f	-20°C	-	260	350	ms
		0°C	-	62	85	ms
		+25°C	-	24	45	ms
		+55°C	-	13	25	ms

				DATE: 16-12-2004	Technical Specification Aries display LPU4CG031B (ALPS Part No)	
				Daniel Homes		
0.2	130241	19.05.2005	Nozaki	COM MD PD HW2 KLF3		
0.1	130241	16.12.2004	Hom			
<u>VERS.</u>	<u>DIS</u>	<u>DATE</u>	<u>NAME</u>	SIEMENS AG		Page 23
FUNCTIONAL STATUS: ALPS						of 48

2.5.10. Cosmetic Defects

See "Product Inspection Provision".

Definitions: Cosmetic Defects

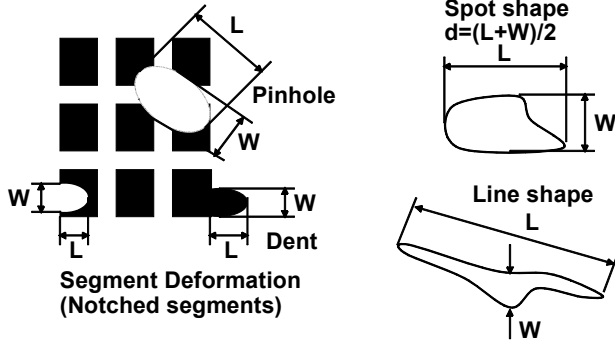

Maximum allowed defect quantity:

Defect Type	Defect Dimension / mm	Maximum defect quantity	
		Active Area	Viewing Area
Black and white spots and foreign substances			
Spot shape	$0.1 < d < 0.2$	1	2
	$0.2 < d < 0.25$	0	1
	$0.25 < d$	0	0
Line shape	$L < 2.0$ $W < 0.02$	1	2
	$L < 1.0$ $W < 0.03$	1	2
	$L < 1.0$ $W < 0.04$	0	1
	$W > 0.04$	0	0
	Total defects		3
Air bubbles between glass and polarizer			
	$0.15 < d < 0.3$	1	1
	$0.3 < d < 0.5$	0	1
	$0.5 < d < 1.0$	0	0
Total defects		1	
Misformed Dots			
Dents	$L < 0.15$ $W < 0.15$	1	
	$L > 0.15$ $W > 0.15$	0	
Pin Holes	$d < 0.2$	1	
	$d > 0.2$	0	
Total defects		1	

No cosmetic defects as defined above shall appear, when the display is placed on a flat block with the size of the active area and is pressed against that flat block with a force between 10N to 20N

				DATE: 16-12-2004	Technical Specification Aries display LPU4CG031B (ALPS Part No)	
				Daniel Homes		
0.2	130241	19.05.2005	Nozaki	COM MD PD HW2 KLF3		
0.1	130241	16.12.2004	Hom			
<u>VERS.</u>	<u>DIS</u>	<u>DATE</u>	<u>NAME</u>	SIEMENS AG		Page 24
FUNCTIONAL STATUS: ALPS						of 48

2.5.11. Pixel Faults

Definition of the pixel fault classes (1000h, Room Temperatur, 1000ppm)

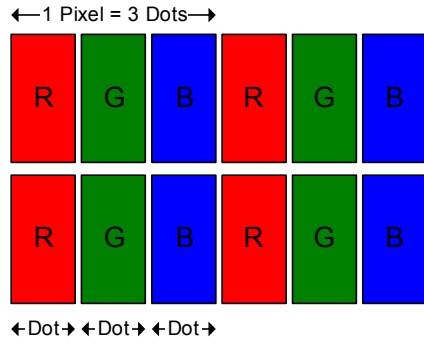

For the characterisation of faults types following definitions should be used

Pixel definition

A pixel consists of 3 sub-pixel (red, green and blue).

Pixel defect

A pixel is defective if a single sub-pixel (dot) cannot be controlled, the pixel is permanent on or off. The pixel defect appears black or bright (red, green or blue)

Verification of pixel faults

Fault Class	maximum Pixel defect	max defect rate for delivered TFD / TFT Modules	reliability belongs to operating time by room temperature during
Complete Pixel	0	0 dpm	life time
Sub Pixel defect	1	1000 dpm	1000 h
Sub Pixel defect	2	300 dpm	1000 h
Sub Pixel defect	3	Not allowed	1000 h

Amount of displays with 1 total dot defect per display, during volume delivery: < 6% (Within 250K pieces).

				DATE: 16-12-2004	Technical Specification Aries display LPU4CG031B (ALPS Part No)	
				Daniel Homes		
0.2	130241	19.05.2005	Nozaki	COM MD PD HW2 KLF3		
0.1	130241	16.12.2004	Hom			
<u>VERS.</u>	<u>DIS</u>	<u>DATE</u>	<u>NAME</u>	SIEMENS AG		Page 25
FUNCTIONAL STATUS: ALPS						of 48

3. Electrical Characteristics

3.4.1. Display Controller

See also Display Controller Specification: SSD1286

3.4.1.1. Hardware-Settings

Operating mode, fixed by hardware coding on the Module:

Module identification, fixed by hardware coding on the Module: See 3.4.3.

3.4.1.2. Software-Settings

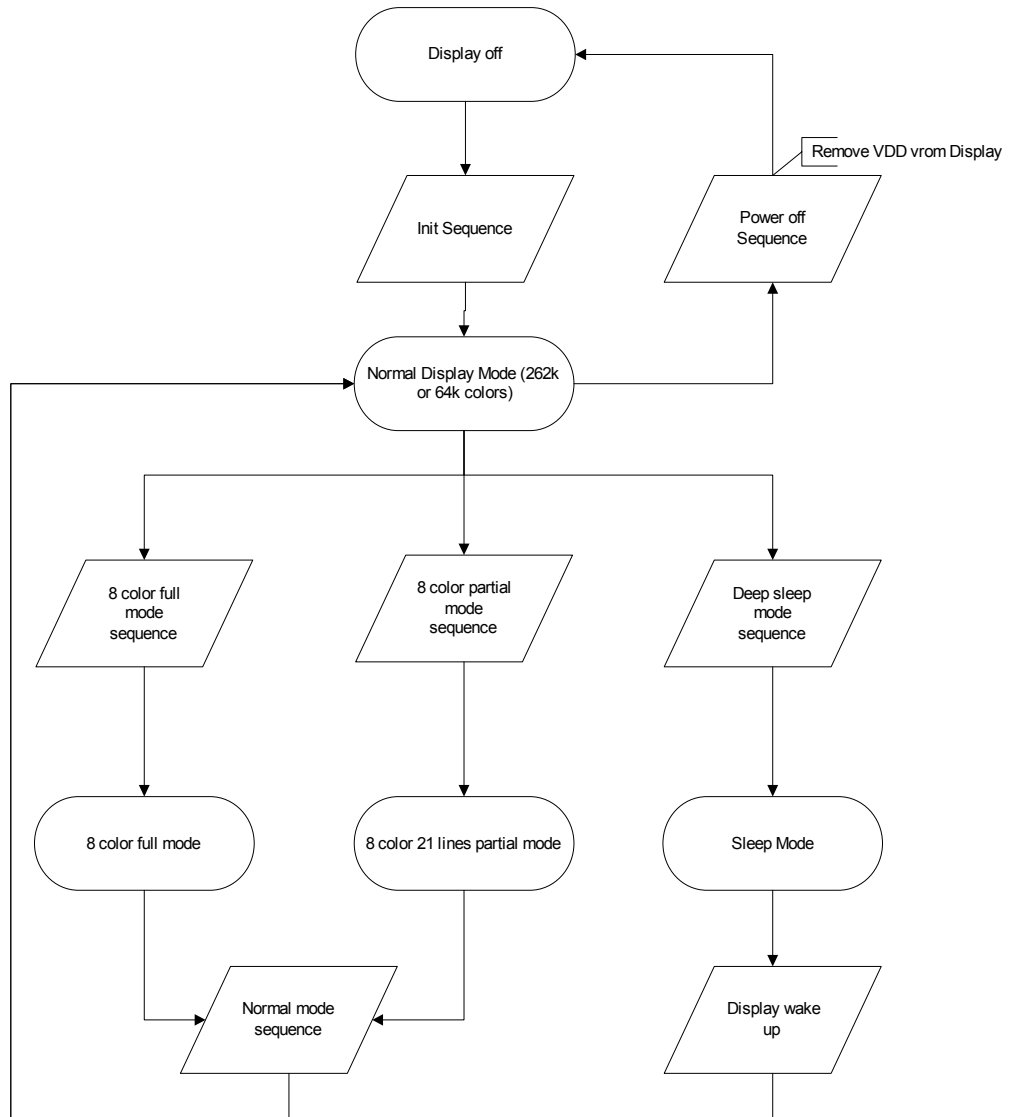

				DATE: 16-12-2004	Technical Specification Aries display LPU4CG031B (ALPS Part No)	
				Daniel Homes		
0.2	130241	19.05.2005	Nozaki	COM MD PD HW2 KLF3		
0.1	130241	16.12.2004	Hom			
<u>VERS.</u>	<u>DIS</u>	<u>DATE</u>	<u>NAME</u>	SIEMENS AG		Page 26
FUNCTIONAL STATUS: ALPS						of 48
Aries 132x176 1.8 TFT Alps TTD V1						

Power On Sequence (Init Sequence)

POWER ON	262k colours	
Operation	8bit Command (RS=LO)+Data (RS=HI)	
	Address (Hex)	Parameter (Hex)
Hardware RESET		
Oscillation start	00	0001
Power control (1)	10	1F92
Power control (2)	11	0014
Oscillation start	00	0001
Power control (1)	10	1F92
Power control (2)	11	0014
Test Enable	28	0006
LCD drive AC	02	0000
Power control (3)	12	040B
Entry mode	03	4830
Driver output control	01	31AF
Display control	07	0033
Hor. RAM address	44	8300
Ver. RAM address	45	AF00
Oscillator frequency	2C	3000
Analog Tune	2D	310F
RAM data write	22	...

For 65k colour you must write 6830 (Hex) instead of 4830 (Hex) to register 03 (Hex)

Normal Mode (262k color, full screen):

Normal Mode	(Full Mode 262k colour)	
Operation	8bit Command (RS=LO)+Data (RS=HI)	
	Address (Hex)	Parameter (Hex)
Oscillation start	00	0001
Power control (1)	10	1F92
Power control (2)	11	0014
Test Enable	28	0006
Oscillation start	00	0001
Power control (1)	10	1F92
Power control (2)	11	0014
LCD drive AC control	02	0000
Power control (3)	12	040B
Entry mode	03	4830
Driver output control	01	31AF
Display control	07	0033
1st Screen driving	42	AF00
RAM address set	21	0000
Hor. RAM address	44	8300
Ver. RAM address	45	AF00
Oscillator frequency	2C	3000
Analog Enable	29	0000
Power Control 4	13	3000
RAM data write	22	...

For 65k colour you must write 6830 (Hex) instead of 4830 (Hex) to register 03 (Hex)

				DATE: 16-12-2004	Technical Specification Aries display LPU4CG031B (ALPS Part No)	
				Daniel Homes		
0.2	130241	19.05.2005	Nozaki	COM MD PD HW2 KLF3		
0.1	130241	16.12.2004	Hom			
<u>VERS.</u>	<u>DIS</u>	<u>DATE</u>	<u>NAME</u>	SIEMENS AG		Page 27
FUNCTIONAL STATUS: ALPS						of 48

Low Power Mode:

1. Full screen (8 colour):

265k to 8 Color	(Full Mode 8 colour)	
Operation	8bit Command (RS=LO)+Data (RS=HI)	
	Address (Hex)	Parameter (Hex)
Oscillation start	00	0001
Power control (1)	10	1F92
Power control (2)	11	0014
VCOM OTP	29	FFCE
Power control (1)	10	1B92
Power control (2)	11	0004
Display control	07	0000
Analog enable	29	C3F0
Power control (4)	13	0000
Oscillation start	00	0001
Power control (1)	10	1F92
LCD drive AC	02	0000
Entry mode	03	4830
Driver output control	01	31AF
Display control	07	0000
Power control (2)	11	0004
VCOM OTP (1)	28	0006
Change to full mux	42	AF00
RAM address set	21	0000
Hor. RAM address	44	8300
Ver. RAM address	45	AF00
Power control (1)	10	1B92
Power control (2)	11	0004
Oscillator frequency	2C	3000
Display control	07	003B
Analog enable	29	C3F0
Power control (4)	13	0000
RAM data write	22	...

For 65k colour you must write 6830 (Hex) instead of 4830 (Hex) to register 03 (Hex)

				DATE: 16-12-2004	Technical Specification Aries display LPU4CG031B (ALPS Part No)	
				Daniel Homes		
0.2	130241	19.05.2005	Nozaki	COM MD PD HW2 KLF3		
0.1	130241	16.12.2004	Hom			
<u>VERS.</u>	<u>DIS</u>	<u>DATE</u>	<u>NAME</u>	SIEMENS AG		Page 28
FUNCTIONAL STATUS: ALPS						of 48

2. Partial screen (8 colour):

265k to 8 Colour Partial	(Partial Mode 8 colour)	
Operation	8bit Command (RS=LO)+Data (RS=HI)	
	Address (Hex)	Parameter (Hex)
Oscillation start	00	0001
Power control (1)	10	1F92
Power control (2)	11	0014
VCOM OTP	29	FFCE
Power control (1)	10	1B92
Power control (2)	11	0004
Display control	07	0000
Analog enable	29	C3F0
Power control (4)	13	0000
Oscillation start	00	0001
Power control (1)	10	1F92
LCD drive AC control	02	0000
Entry mode	03	4830
Driver output control	01	31AF
Display control	07	0000
Hor. RAM address	44	8300
Ver. RAM address	45	AF00
Power control (2)	11	0004
Test Enable	28	0006
Change to partial	42	634E
RAM Address set	21	4E00
Power control (1)	10	1B92
Power control (2)	11	0004
Oscillator frequency	2C	3000
Display control	07	003B
Analog enable	29	C3F0
Power control (4)	13	0000
RAM data write	22	...

For 65k colour you must write 6830 (Hex) instead of 4830 (Hex) to register 03 (Hex)

Deep Sleep Mode:

Full Mode Deep Sleep Mode		
Operation	8bit Command (RS=LO)+Data (RS=HI)	
	Address (Hex)	Parameter
Display control	07	0000
Sleep Mode	10	1F93
Full Mode Release Deep Sleep Mode		
Operation	8bit Command (RS=LO)+Data (RS=HI)	
	Address (Hex)	Parameter
Sleep Mode	10	1F92
Display control	07	0033

				DATE: 16-12-2004	Technical Specification Aries display LPU4CG031B (ALPS Part No)	
				Daniel Homes		
0.2	130241	19.05.2005	Nozaki	COM MD PD HW2 KLF3		
0.1	130241	16.12.2004	Hom			
<u>VERS.</u>	<u>DIS</u>	<u>DATE</u>	<u>NAME</u>	SIEMENS AG		Page 29
FUNCTIONAL STATUS: ALPS						of 48

Temperature Compensation:

No external Temperature Compensation necessary, because it is implemented in the module

3.4.1.3. Gradation Palette Palette (Gamma Correction)

Register No	Register	Upper	Lower
R30h	control(1)	00h	00h
R31h	control(2)	06h	04h
R32h	control(3)	07h	07h
R33h	control(4)	00h	00h
R34h	control(5)	00h	00h
R35h	control(6)	03h	01h
R36h	control(7)	07h	07h
R37h	control(8)	00h	00h
R38h	control(9)	00h	07h
R39h	control(10)	06h	04h

Measurement conditions:

Measuring Equipment	Autronic DMS ALPS : Topcon BM-5A
Objective	
Measurement Point Location	No. 13
Light Source	Transmissive Mode: internal (backlight)
Lighting Distance d _L	
Test pattern	Grey scales 0 – 31 (i.e. black to white)

$$L = (L_w - L_b) x^\gamma + L_b$$

where:

- L= luminance measured for grey scale x (has a value between 0 and 1)
- x= normalized grey scale (x=0 for a black picture, x=1 for a white picture)
- L_w = luminance measured for a white picture
- L_b = luminance measured for a black picture

step 1:

Measure Luminance for 32 grey scales (x ranges from 0 to 1) -> measured values (L)

step 2:

Subtract the luminance value for grey scale x=0 (i.e. black) from all measured values -> corrected measured values (i.e. L – L_b)

step 3:

Normalise all values that the maximum value is one-> Divide all Values by maximum corrected measured value -> normalised value (i.e. (L – L₀)/(L₃₁ – L₀) where L₃₁ is luminance measured for x=1)

step 4:

Determine the gamma correction value of the display according formula above by least square fit

Item	Symbol	Condition	Rating		
			Min.	Typ.	Max
Gamma correction value	γ	perpendicular measurement	1.9	2.2	2.5

				DATE: 16-12-2004	Technical Specification Aries display LPU4CG031B (ALPS Part No)	
				Daniel Homes		
0.2	130241	19.05.2005	Nozaki	COM MD PD HW2 KLF3		
0.1	130241	16.12.2004	Hom			
<u>VERS.</u>	<u>DIS</u>	<u>DATE</u>	<u>NAME</u>	SIEMENS AG		Page 30
FUNCTIONAL STATUS: ALPS						of 48
Aries 132x176 1.8 TFT Alps TTD V1						

3.4.2. DC Characteristics

GND = 0V, Vdd = Vddtyp, Temp = 25°C unless noted otherwise

Item	Symbol	Condition	Rating			Unit
			Min.	Typ.	Max	
Logic Supply Voltage	V _{DD}	-	2.80	2.90	3.00	V
High-level Input Voltage	V _{ICH}	-	0.75xVdd		Vdd	V
Low-level Input Voltage	V _{IL}	-	0		0.15xVdd	V
Input Leakage Current	I _{IN}	-	-10	-	10	µA
Supply Voltage DC/DC	V _{EE}	-	2.80	2.90	3.00	
Supply Current	I _{DD}	1-pixel alternating chess pattern Normal Mode (262k),	-	2100	2900	µA
Supply Current	I _{DD}	Idle Bitmap *1) Normal Mode (262k)	-	1800	2600	µA
Supply Current	I _{DD}	Random Bitmap *1) Normal Mode (262k)	-	1900	2600	µA
Supply Current	I _{DD}	Low Power Mode, 8 colours any Bitmap	-	400	600	µA
Supply Current	I _{DD}	Partial Display Mode, 21lines, 8 colours any Bitmaps	-	400	600	µA
Supply Current	I _{DD}	Low Power Mode Deep Sleep Mode	-	100	400	µA
Supply Current	I _{DD}	full video mode 65k colours (15fps) Random data transmission	-	2100	2900	µA

3.4.2.1. Test Pattern



Idle Bitmap
(idle_132x176.bmp)



Random Bitmap
(random_1_13.bmp)

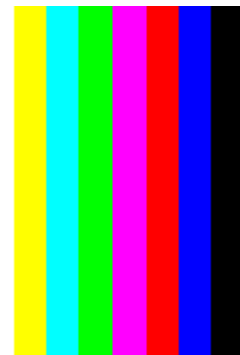

8-colour bar bitmap
(8_colour_bar.bmp)

				DATE: 16-12-2004	Technical Specification Aries display LPU4CG031B (ALPS Part No)	
				Daniel Homes		
0.2	130241	19.05.2005	Nozaki	COM MD PD HW2 KLF3		
0.1	130241	16.12.2004	Hom			
<u>VERS.</u>	<u>DIS</u>	<u>DATE</u>	<u>NAME</u>	SIEMENS AG		Page 31
FUNCTIONAL STATUS: ALPS						of 48

3.4.3. Interface

- serial interface
- Speed serial: 10 Mbit/s
- Connection: 10-pins incl. power supply (Spring connector on Siemens PCB)
- for synchronisation of the internal display refresh and the data transfer to the display a synchronisation pin is implemented (tearing pin LCD_SYNC)
- Connection lines and pinning:

Pin description:

Siemens Side				Supplier side	
Pin Number	Pin Name	Description	I/O	FPC	controller
1	LCD_RS	Control / display data flag	O	LCD_RS	DC
2	LCD_RESET	Reset (low active)	O	LCD_RESET	RES
3	LCD_CS	Chip select main display (low active)	O	LCD_CS	CS
4	LCD_SYNC	Tearing pin (synchronisation of display refresh and data transmission)	I	LCD_SYNC	WSYNC
5	LCD_CLK	Power supply GND	-	LCD_CLK	SCK
6	LCD_DATA	Parallel data bus	O	LCD_DATA	SDI
7	VDD=2.9V	Power supply V _{DD1}	O	VDD=2.9V	VDD1
8	LCD_GND	Power supply GND	-	LCD_GND	GND
9	LCD_LED_A	Anode LED	O	LCD_LED_A	LED_A
10	LCD_LED_C	Cathode LED	O	LCD_LED_C	LED_C

nc: not connected

				DATE: 16-12-2004	Technical Specification Aries display LPU4CG031B (ALPS Part No)	
				Daniel Homes		
0.2	130241	19.05.2005	Nozaki	COM MD PD HW2 KLF3		
0.1	130241	16.12.2004	Hom			
<u>VERS.</u>	<u>DIS</u>	<u>DATE</u>	<u>NAME</u>	SIEMENS AG		Page 32
FUNCTIONAL STATUS: ALPS						of 48

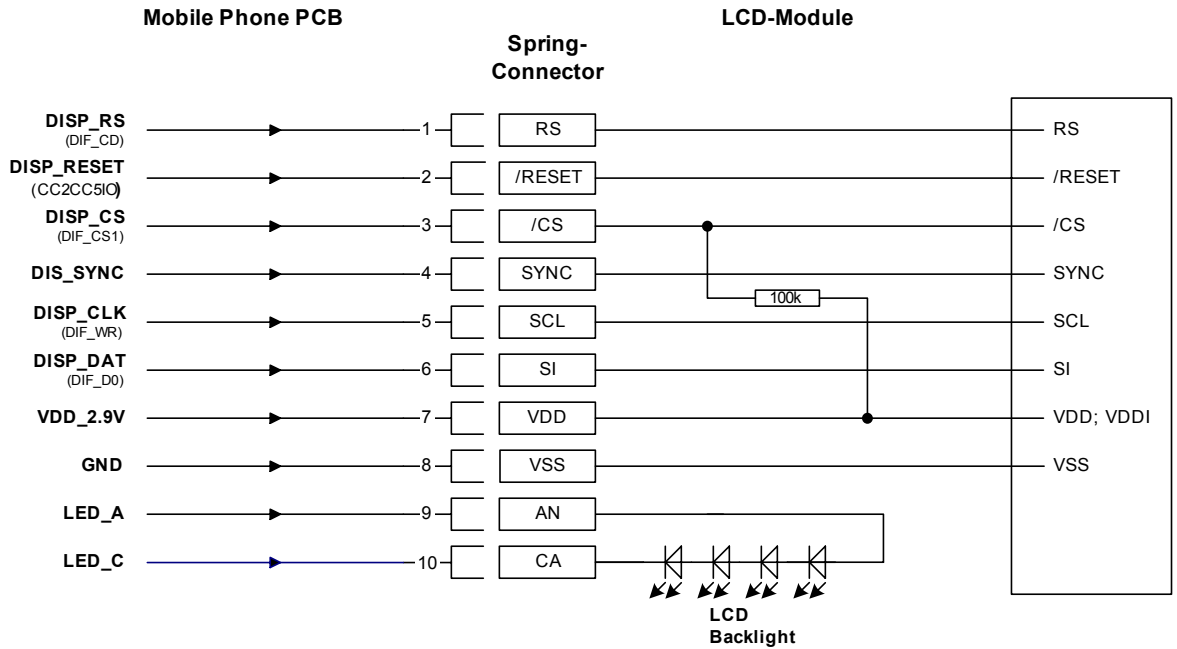

Schematic drawing of spring connector interface

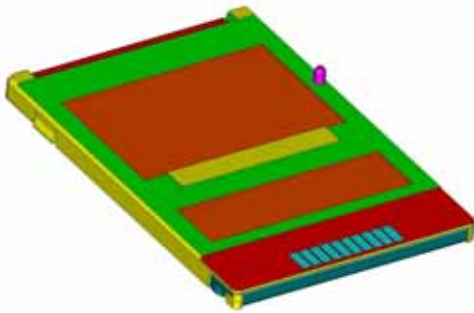

Item	Symbol	Condition	Rating			Unit
			Min.	Typ.	Max	
Contact Resistance	R _c	Operating Force = 0,5 N	-	-	150	mΩ
VDD, RESET\ Contact Interruption Time (mech. shock)	T _{int}	Module full functional, no data transmission	1		-	ms

				DATE: 16-12-2004	Technical Specification Aries display LPU4CG031B (ALPS Part No)	
				Daniel Homes		
0.2	130241	19.05.2005	Nozaki	COM MD PD HW2 KLF3		
0.1	130241	16.12.2004	Hom			
<u>VERS.</u>	<u>DIS</u>	<u>DATE</u>	<u>NAME</u>	SIEMENS AG		
FUNCTIONAL STATUS: ALPS						Page 33 of 48

4.4.4. Module Assembly On Siemens PCB

Full automatic assembling

The complete display module will be automatically assembled on the Siemens PCB. In order to click the display module in the metal frame, the display will be taken from the tray with a gripper arm. The gripper will press with a maximum force of 90N on the north and the south side of the display. Afterwards the gripper arm will place the display on the Siemens PCB and press it with a maximum force of 180 N in to the metal frame for a maximum time of 1 sec. No influence on module functionality allowed by assembly.

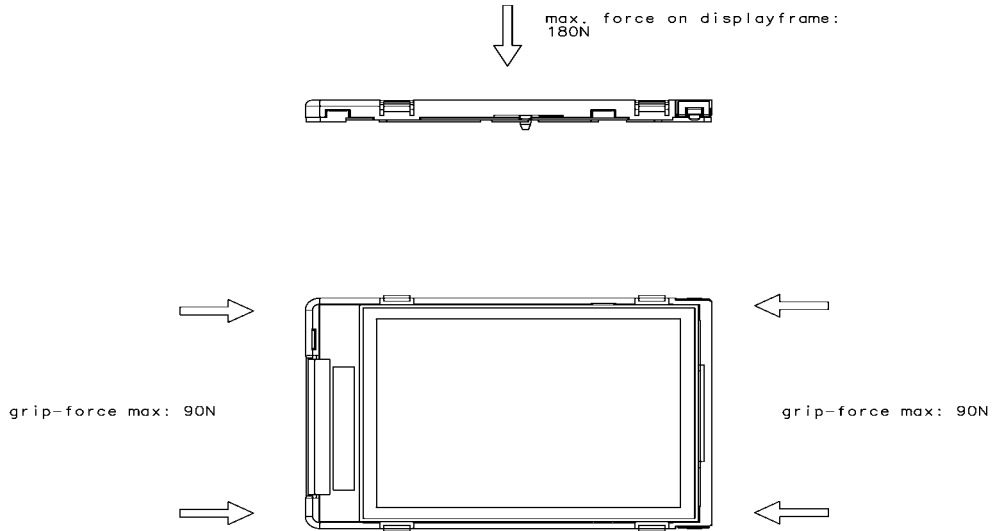

Semi automatic assembling

The complete display module will be semi - automatically assembled on the Siemens PCB. In order to click the display module in the metal frame, the display module is placed in a POM holder on the glass side as shown below and pressed with a maximum force of 180 N in the metal frame for a maximum time of 1 sec. No influence on module functionality allowed by assembly.

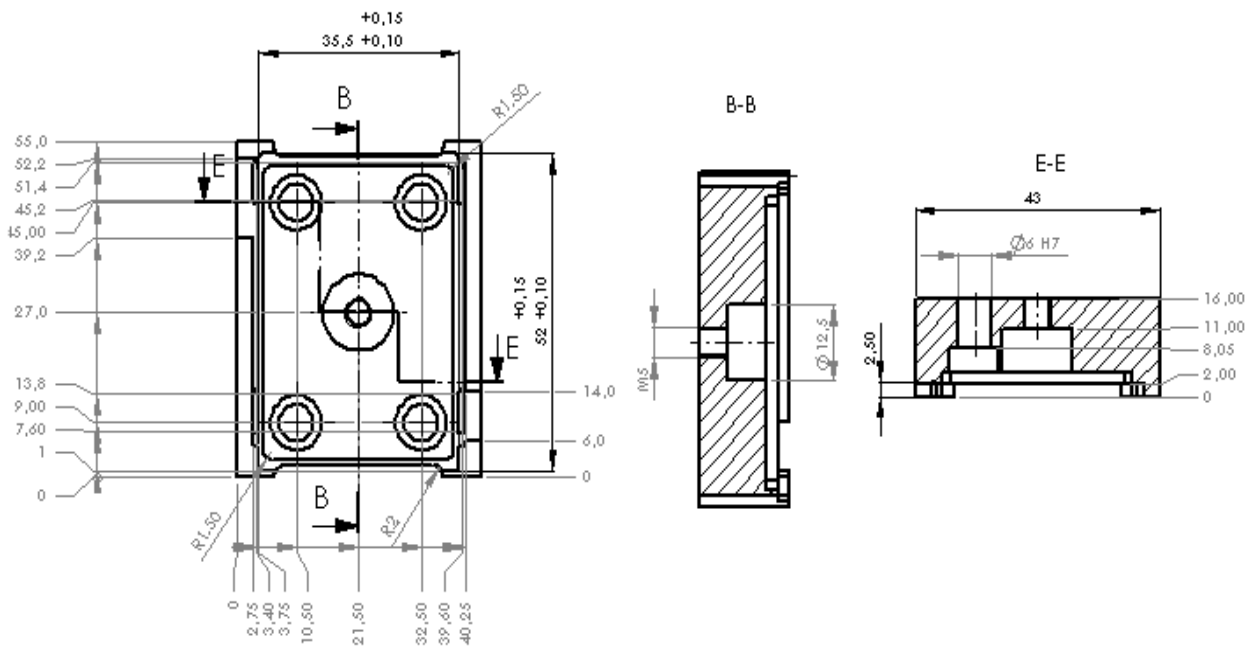

				DATE: 16-12-2004	Technical Specification Aries display LPU4CG031B (ALPS Part No)	
				Daniel Homes		
0.2	130241	19.05.2005	Nozaki	COM MD PD HW2 KLF3		
0.1	130241	16.12.2004	Hom			
<u>VERS.</u>	<u>DIS</u>	<u>DATE</u>	<u>NAME</u>	SIEMENS AG		Page 35
FUNCTIONAL STATUS: ALPS						of 48
Aries 132x176 1.8 TFT Alps TTD V1						

4.4.5. ITO Corrosion Protection

The ITO patterns are covered in order to avoid ITO corrosion.
No chemical reaction between the ITO-protection, the ACF and the cushion is allowed.

4.4.6. Dangerous Substances (according SN36350 Part 2)

The component must not contain any dangerous substances e.g.:

- Cadmium
- Chlorofluorocarbons
- Organic compounds that are harmful for handy and user
- Asbestos or asbestos materials
- Acid materials

4.4.7. Tensile Strength (EN 843-1 or JIS for ceramic bending measurement)

Tensile Strength (EN 843-1 or JIS for ceramic bending measurement)

Test has to be done with a complete LCD-panel!

This test is not subject for rejection of materials. The test results have to be reported to Siemens monthly.

test conditions for 4-point-bending-test:

- notice temperature (20-30°C) and humidity (40-60 %),
- distance of the lower cylinders: 20 mm
- distance of the upper cylinders: 10 mm
- adjust sample centric like seen in PICTURE 1 below
- adjust sample centric like seen in PICTURE 2 below is optional test setup upon request
- pre load max. 2 N (for external displacement measurement),
- traverse speed (loading speed): 1.7 mm/min,
- fracture force: first drop (> 10 N) in the force-displacement-diagram,
- document fracture force and displacement at this point for each sample,
- Sample frequency (how many, and when test samples taken out from mass production): when in mass production 5 samples per shift
- The detailed test specification, as the test is conducted by supplier, should be provided upon request.

Test-cylinder diameter of Siemens: 5 mm

Test-cylinder diameter: 4 mm

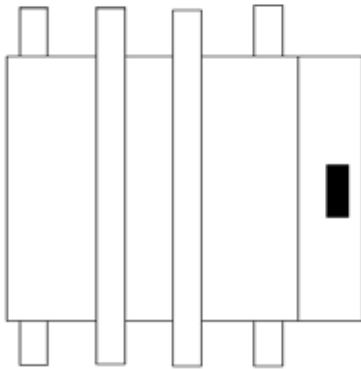

PICTURE 1

(smaller glass is facing up)

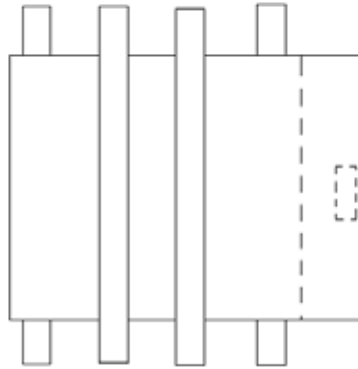

PICTURE 2

(larger glass is facing up)

				DATE: 16-12-2004	Technical Specification Aries display LPU4CG031B (ALPS Part No)	
				Daniel Homes		
0.2	130241	19.05.2005	Nozaki	COM MD PD HW2 KLF3		
0.1	130241	16.12.2004	Hom			
<u>VERS.</u>	<u>DIS</u>	<u>DATE</u>	<u>NAME</u>	SIEMENS AG		<u>Page</u> 36
FUNCTIONAL STATUS: ALPS						of 48

4.4.8. Chipped glass edges (of LCD-panel)

Definition: Chipped glass edge:

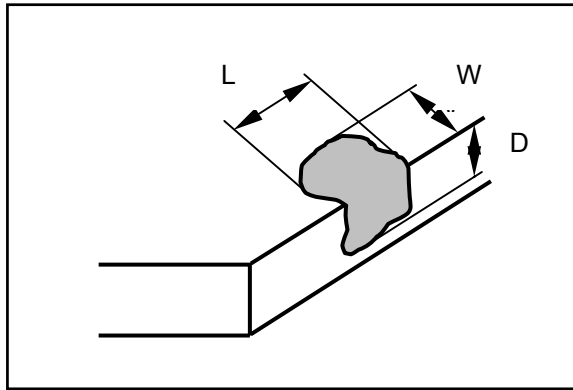

Characteristics:

Type of defect	LCD glass cut to size	
Chip along the seal line Excluding corners	Length (L) \leq 2.0 mm	ignore
	Width (W) \leq 0.3 mm	
	Depth (D) < glass thickness	
	Length (L) > 2.0mm	none
Width (W) > 0.3 mm		
Depth (D) = glass thickness		
crack	Visibility	none

				DATE: 16-12-2004	Technical Specification Aries display LPU4CG031B (ALPS Part No)	
				Daniel Homes		
0.2	130241	19.05.2005	Nozaki	COM MD PD HW2 KLF3		
0.1	130241	16.12.2004	Hom			
<u>VERS.</u>	<u>DIS</u>	<u>DATE</u>	<u>NAME</u>	SIEMENS AG		
FUNCTIONAL STATUS: ALPS						Page 37 of 48
Aries 132x176 1.8 TFT Alps TTD V1						

5. Climatic- And Environmental Tests As Performed by Siemens

The following tests are made by Siemens with complete assembled mobile phones. For tests done above 80°C and or longer than 504hr. Siemens accepts aging effects on E/O parameters (e.g. shifting of colour co-ordinates, etc.)

5.1. Test Standard Conditions

The following standard conditions apply unless the individual conditions specify otherwise:

Temperature	23 ± 5	°C
Air Pressure	860 to 1060	mbar
Rel. Humidity	45 to 75	%RH
Hard- and Software settings	as specified in chapter "Electrical Characteristics"	

5.2. Mechanical Stress Tests

5.2.1. Mechanical Test Series

The mechanical test sequence is an arrangement of single tests described below. The specimen has to go through all the tests in the given order.

Step 1: Vibration
Complete test procedure See chap. 5.3.2

Step 2: Vibration random
Complete test procedure See Chap. 5.3.3

Step 3: Shock
Complete test procedure See Chap. 5.3.4

Step 4: Shock (continuous shock test)
Complete test procedure See Chap. 5.3.5

Product requirements
No mechanical damage to the device

Step 1: Vibration
Valid standard DIN IEC 68-2-36
ETS 300019-2-7

Frequency range	10 to 20 Hz	20 to 500 Hz
Acceleration	3.1 mm amplitude	5 g
Duration	2 h for each position (axis) = 10 repetitions	
Test	all 3 axes (X, Y, Z)	
Phone	ON	

Step 2: Vibration random
Type random vibration

Frequency range	10 to 12 Hz	12 to 150 Hz
Acceleration	1.92 m ² /s ³ = 0.02g ² /Hz	-3 dB/oct.
Duration	3 x 30 minutes	
Test	all 3 axes (X, Y, Z)	
Phone	ON	

				DATE: 16-12-2004	Technical Specification Aries display LPU4CG031B (ALPS Part No)	
				Daniel Homes		
0.2	130241	19.05.2005	Nozaki	COM MD PD HW2 KLF3		
0.1	130241	16.12.2004	Hom			
<u>VERS.</u>	<u>DIS</u>	<u>DATE</u>	<u>NAME</u>	SIEMENS AG		Page 38
FUNCTIONAL STATUS: ALPS						of 48

Step 3: Shock

Type semi-sinusoidal current
 Acceleration 500 g
 Shock duration 1 ms
 Number of shocks 1 shock / axis
 Test 3 axes = 6 positions (± X, Y, Z)
 Phone ON

Step 4: Shock (continuous shock test)

Acceleration 25 g
 Shock duration 6 ms
 Number of shocks 1000 shocks per position
 Test 3 axes = 6 positions (± X, Y, Z)
 Phone ON

5.2.2. Vibration With Temperature

Type	vibration	
Frequency range	10 to 20 Hz	20 to 500 Hz
Acceleration	3.1 mm amplitude	5 g
Temperature range	-25°C and +65°C	
Duration	2 h / axis and temperature	
Test	3 axes	
Phone	OFF	

5.3. Climatic Stress Tests

5.3.1. Climatic Test Sequence

The climatic test sequence is an arrangement of single tests described below. The specimen has to go through all the tests in the given order. The specimen has to be checked after each test.

Step 1: Dry heat

Complete test procedure See Chap. 5.3.2

Step 2: Temperature shock

Complete test procedure See Chap. 5.3.3

Step 3: Damp heat

Complete test procedure See Chap. 5.3.4

exception:

Number of repetitions 1 of 6

Step 4: Constant cold

Complete test procedure See Chap. 5.3.5

Step 5: Damp heat

See Chap. 5.3.4

Complete test procedure

exception:

Number of repetitions 5 of 6

Product requirements

No changes on the test sample

				DATE: 16-12-2004	Technical Specification Aries display LPU4CG031B (ALPS Part No)	
				Daniel Homes		
0.2	130241	19.05.2005	Nozaki	COM MD PD HW2 KLF3		
0.1	130241	16.12.2004	Hom			
<u>VERS.</u>	<u>DIS</u>	<u>DATE</u>	<u>NAME</u>	SIEMENS AG		Page 39
FUNCTIONAL STATUS: ALPS						of 48

5.3.2. Dry Heat

Valid standards EN 60068-2-2
ETS 300019-2-7

Temperature 70°C ± 2°C
Humidity < 50%
Test duration 16h
Phone OFF

Product requirements

No changes on the test sample

5.3.3. Temperature Change (shock)

Valid standard DIN IEC 68-2-14 nb
ETS 300019-2-7

High temperature +85°C ± 2°C
Low temperature -40°C ± 2°C
Temp. changeover time <30 sec.
(dual chamber system)
Test duration 1h
Number of repetitions 100
Phone OFF

TC 1102
TEMPERATURE CHANGE (SHOCK)

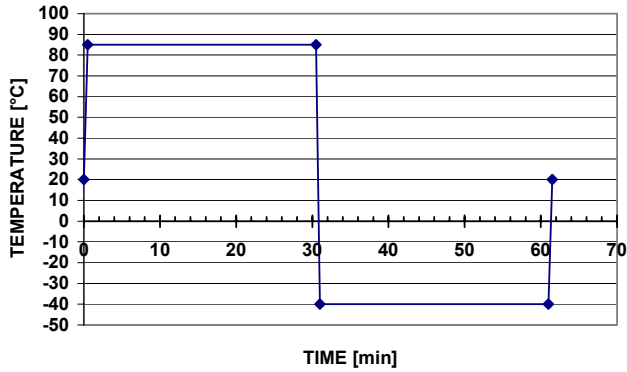

Product requirements

No changes on the test sample

				DATE: 16-12-2004	Technical Specification Aries display LPU4CG031B (ALPS Part No)	
				Daniel Homes		
0.2	130241	19.05.2005	Nozaki	COM MD PD HW2 KLF3		
0.1	130241	16.12.2004	Hom			
<u>VERS.</u>	<u>DIS</u>	<u>DATE</u>	<u>NAME</u>	SIEMENS AG		Page 40
FUNCTIONAL STATUS: ALPS						of 48

5.3.4. Damp Heat Cycle

Valid standards	DIN IEC 68-2-30 Db Variant 1 ETS 300019-2-5 ETS 300019-2-7
High temperature	55°C ± 2°C
Low temperature	25°C ± 2°C
Humidity	93% ± 3%
Test duration	12h + 12h
Number of repetitions	6
Phone	ON

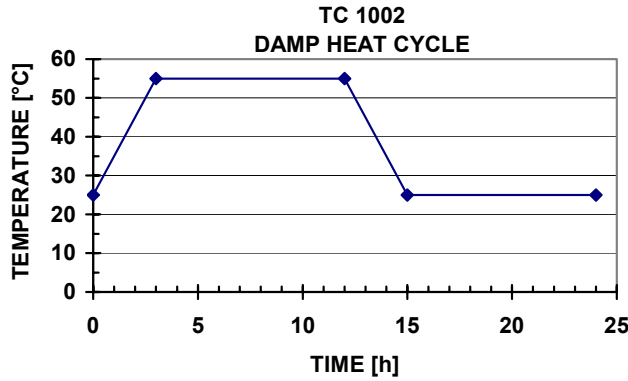

Product requirements

No changes on the test sample

5.3.5. Constant Cold

Valid standard	DIN IEC 68-2-1
Temperature	-40°C ± 2°C
Test duration	16h
Phone	OFF

Product requirements

No changes on the test sample

				DATE: 16-12-2004	Technical Specification Aries display LPU4CG031B (ALPS Part No)	
				Daniel Homes		
0.2	130241	19.05.2005	Nozaki	COM MD PD HW2 KLF3		
0.1	130241	16.12.2004	Hom			
<u>VERS.</u>	<u>DIS</u>	<u>DATE</u>	<u>NAME</u>	SIEMENS AG		Page 41
FUNCTIONAL STATUS: ALPS						of 48

5.3.6. Temperature Change With Gradient

Valid standard DIN IEC 68-2-14 nb
 High temperature +85°C ± 2°C
 Low temperature -40°C ± 2°C
 Temperature change 1°C ± 0,2°C / min
 Test duration 8h
 Number of cycles 10
 Phone OFF

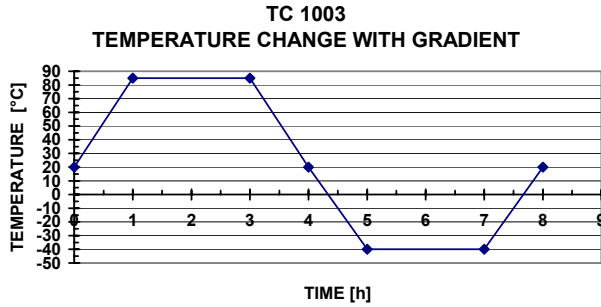

Product Requirements

No changes on the device

5.3.7. Heat With Solar Radiation

Valid standard DIN IEC 68-2-5
 Ambient temperature 55°C ± 2°C
 Irradiation level 1120 W/m²
 Duration of irradiation 8h
 Storage time in the dark 16h
 Storage temperature in the dark 25° ± 3°C
 Number of cycles 1
 Phone OFF

Product Requirements

No changes on the device
 No aging

				DATE: 16-12-2004	Technical Specification Aries display	
				Daniel Homes		
0.2	130241	19.05.2005	Nozaki	COM MD PD HW2 KLF3		
0.1	130241	16.12.2004	Hom		LPU4CG031B (ALPS Part No)	
<u>VERS.</u>	<u>DIS</u>	<u>DATE</u>	<u>NAME</u>	SIEMENS AG		Page 42
FUNCTIONAL STATUS: ALPS						of 48

Product requirements

The function of the device may not be impaired or affected in any way.
 The test device may not evidence any mechanical damage (no loose parts).

5.4.3. Aging By Temperature

Temperature 85°C
 Test duration 1000 h
 Phone OFF
 Half of the devices have to evaluated after the stress duration of 500 h.

Product Requirements

No damages on the test sample

5.4.4. Aging By Damp Heat Constant

Valid standard DIN IEC 68-2-56
 ETS 300019-2-7
 Temperature 40°C ± 3°C
 Humidity 93% ± 2%
 Test duration 42 days
 Phone OFF
 Half of the devices have to evaluated after the stress duration of 500 h.

Product requirements

The function of the test device may not be impaired or affected in any way.
 The test device may not evidence any mechanical damage (no loose parts).

5.4.5. Mixed Gases And Damp Heat (Cyclic)

Step 1: Concentration of gases

Valid standards EN 60068-2-60, Method 4
 SO₂ 0.20 ppm
 H₂S 0.01 ppm
 NO₂ 0.20 ppm
 Cl₂ 0.01 ppm
 Temperature 25°C ± 2°C
 Humidity 75% ± 3% (rel)
 Test duration 10 days
 Phone OFF

Step 2: Damp heat cycle

See Chap. 5.3.4

Phone OFF

Product requirements

Corrosion is not allowed
 No changes on the device

				DATE: 16-12-2004	Technical Specification Aries display LPU4CG031B (ALPS Part No)	
				Daniel Homes		
0.2	130241	19.05.2005	Nozaki	COM MD PD HW2 KLF3		
0.1	130241	16.12.2004	Hom			
<u>VERS.</u>	<u>DIS</u>	<u>DATE</u>	<u>NAME</u>	SIEMENS AG		Page 44
FUNCTIONAL STATUS: ALPS						of 48

5.5. Other Tests

5.5.1. ESD

1) Test of Device

Human Body Model

Contact discharge 1 kV

Conditions LCD Module connect to FRAME GND.

LCD Module not operate.

Points

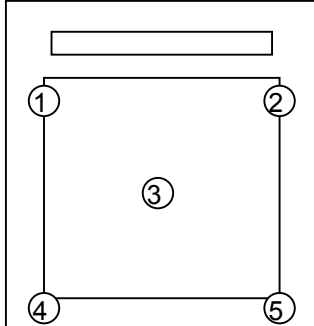

2) Test within Mobile Phone (ALPS can't test it, Test done at Siemens site)

The test is only applied to complete assembled mobile phones.

Test according IEC 61000-4-2,
test level see a) and b)

- a) Contact discharge 8 kV
Air discharge 15 kV
without ground connection
- b) Contact discharge 6 kV
Air discharge 12 kV
with ground connection

For 2a) and 2b) no malfunction of the display is allowed up to 4kV contact discharge and 8 kV air discharge.

No permanent damages allowed above 4kV contact discharge and above 8kV air discharge

5.5.2. Ambient Light Sensitivity

Full functional under sunlight exposure with an luminance of 100.000 Lx
(Exposure to sunlight)

The test is only applied to complete assembled mobile phones.

5.5.3. Resistance to EMI

The LCD module is functional under all GSM conditions. The module has to pass the Siemens EMI test.
The test is only applied to complete assembled mobile phones.

				DATE: 16-12-2004	Technical Specification Aries display LPU4CG031B (ALPS Part No)	
				Daniel Homes		
0.2	130241	19.05.2005	Nozaki	COM MD PD HW2 KLF3		
0.1	130241	16.12.2004	Hom			
<u>VERS.</u>	<u>DIS</u>	<u>DATE</u>	<u>NAME</u>	SIEMENS AG		Page 45
FUNCTIONAL STATUS: ALPS						of 48

6. Packaging And Handling Items

6.4. Protection Foil Panel

All display panels are delivered with a protection foil on the panel. The protection foil is easily removable without remains of glue. A coloured pull-up tape to remove the protection foil must be designed. The position of this tape is defined by drawing in the left corner, at the display side across the controller.

6.5. Package

The package must prevent damage to the components during transport and must be suitable for electrostatic-sensitive devices.

No poly vinyl chloride is allowed in the package.

Tray definition (according the Siemens Specification SN72500-1):

- Maximum tray dimensions : 198690 mm²
- Gripping trough on long side, width: 20-25mm
- Surface resistance: $10^5 \leq R_s \leq 10^{10} \text{ M}\Omega$
(Measurement according IEC 1340-5-1)
- All modules should be delivered with the display cover downside (see also tray drawing in appendix 1)
- No alternating tray stack allowed (all modules in one direction)
- The tray pack must be wrapped with one tape to fix the tray stack
- The top tray of the tray pack should be covered always with an empty tray
- Max. dimension of tray pack is 32545422 mm³
- Number of modules per tray: 40 (depends on Module size)
- Recommended box dimensions: 44831232 mm³

				DATE: 16-12-2004	Technical Specification Aries display	
				Daniel Homes		
0.2	130241	19.05.2005	Nozaki	COM MD PD HW2 KLF3		
0.1	130241	16.12.2004	Hom		LPU4CG031B (ALPS Part No)	
<u>VERS.</u>	<u>DIS</u>	<u>DATE</u>	<u>NAME</u>	SIEMENS AG		Page 46
FUNCTIONAL STATUS: ALPS						of 48

6.6. Module And Package Labelling

6.6.1. Module Labelling

Manufacturer component identification:

- C Factory Code
- Y Production year
- WW Week of production month
- AAAAA Lot code
- X Manufacturing Line
- 011* ALPS Control No.

6.6.2. Product Package Labelling

As defined in Logistic Agreement (Appendix of LSA) with

- Siemens Part No. (Siemens SNR, see page 1)
- SAP Material No. (see page 1)
- Manufacturer Name
- Production-date
- Supplier module name

6.6.3. Barcode label on product packaging (Packing for mechanical components)

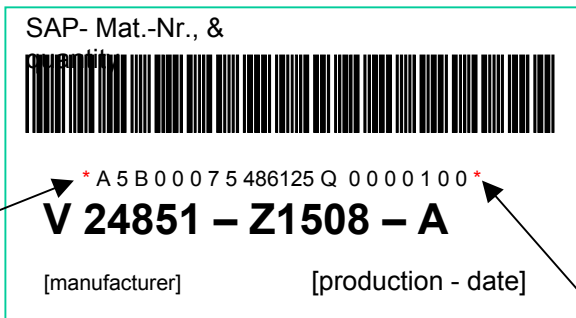

Attention:
Barcode 39 has a (*) as control sign to recognize the beginning and the end of the net data.
The supplier must print this as Barcode Sign in front and into the end of the barcode as defined by CODE 39.
The * must not being print under the barcode in front and into the end of the part number

Barcode – Content

Data	Origin	No. of Symbols	Remarks
Start - Sign	*	1	Start-Sign CODE 39
SAP – Mat.- Nr.	Siemens order	14	A5B00075486125
Q	given	1	
quantity	supplier	7	TBD (7 digits)
End – Sign	*	1	End-Sign CODE 39

The barcode label has to be written in „CODE 39.

Barcode – Description

- Bar Height (inches) 0,25
- Narrow Bar Width (mils) 9
- To Wide Ratio 2,3
- Label size (mm) 100 x 60 (length x height)

				DATE: 16-12-2004	Technical Specification Aries display LPU4CG031B (ALPS Part No)	
				Daniel Homes		
0.2	130241	19.05.2005	Nozaki	COM MD PD HW2 KLF3		
0.1	130241	16.12.2004	Hom			
<u>VERS.</u>	<u>DIS</u>	<u>DATE</u>	<u>NAME</u>	SIEMENS AG		Page 47
FUNCTIONAL STATUS: ALPS						of 48

Label - Content

Data	Origin	No. of Symbols	Remarks
Barcode			
Siemens SNR	Siemens order	max 25	e.g. V24851-Z15-.... Arial 16
manufacturer	supplier	max 20	e.g. Supplier Arial 8
production - date	supplier	10	e.g. 19.06.2004 Arial 8

Criteria And Procedures For Acceptance

See quality assurance agreement document. The acceptance criteria for the delivery like delivery lot, test criteria, test procedures and test reports, are fixed in separate quality assurance agreements (QAA).

6.7. Acceptance Of Technical Specification

We accept the present technical specification

.....
SIEMENS AG

19.05.2005 

PRODUCER

				DATE: 16-12-2004	Technical Specification Aries display LPU4CG031B (ALPS Part No)	
				Daniel Homes		
0.2	130241	19.05.2005	Nozaki	COM MD PD HW2 KLF3		
0.1	130241	16.12.2004	Hom			
<u>VERS.</u>	<u>DIS</u>	<u>DATE</u>	<u>NAME</u>	SIEMENS AG		Page 48
FUNCTIONAL STATUS: ALPS						of 48

SYMB REVISIONS

- (A 1) 0.85 -> 1.25
- (A 2) 12.6±0.1 -> 13.5±0.1
- (A 3) ADD DIMENSION
- (A 4) 1.5 -> 2
- (A 5) ADD DIMENSION
- (A 6) ADD DIMENSION
- (A 7) ADD DIMENSION
- (A 8) ADD DIMENSION
- (A 9) ADD NOTE
- (B 1) CHANGE MOLD CASE
- (B 2) ADD PRODUCT LABEL
- (B 3) ADD NOTE
- (B 4) ADD NOTE
- (B 5) ADD DIMENSION
- (B 6) ADD DIMENSION
- (B 7) 9.9±0.25 -> 9.9±0.3
- (C 1) CHANGE MOLD CASE
- (C 2) CHANGE PROTECTIVE SHEET
- (D 1) ADD INSULATE TAPE

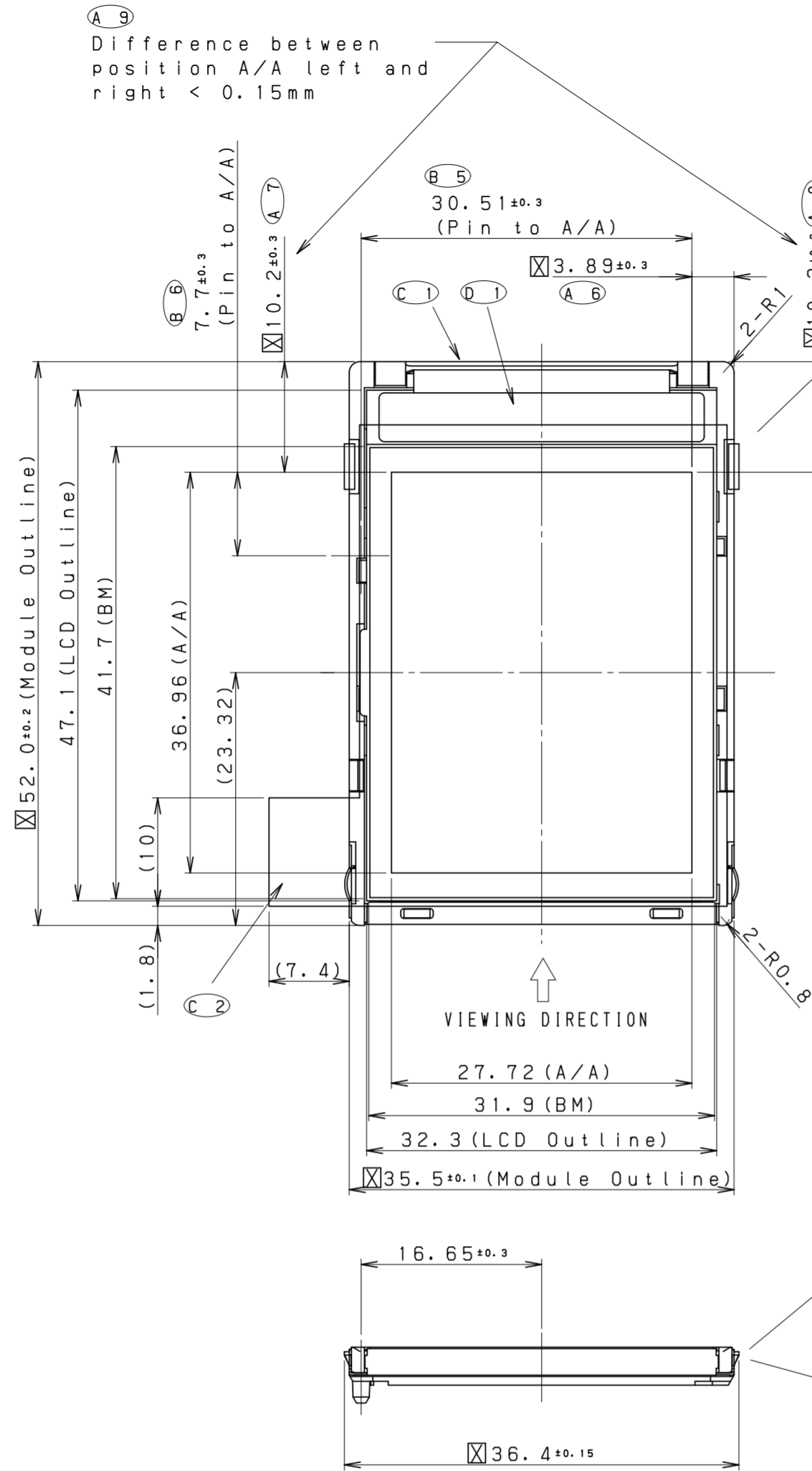

DETAIL Hook

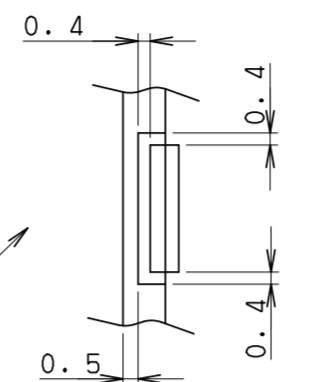

Detail Plastic

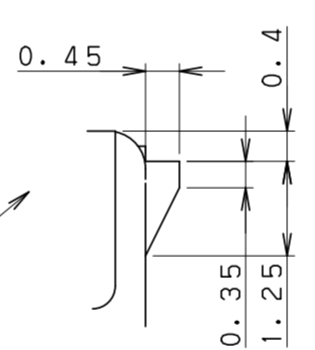

Detail Steel

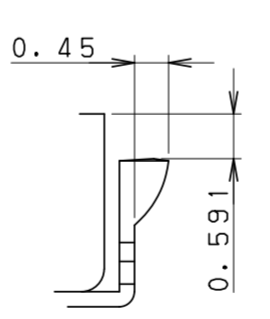

DOT DETAIL

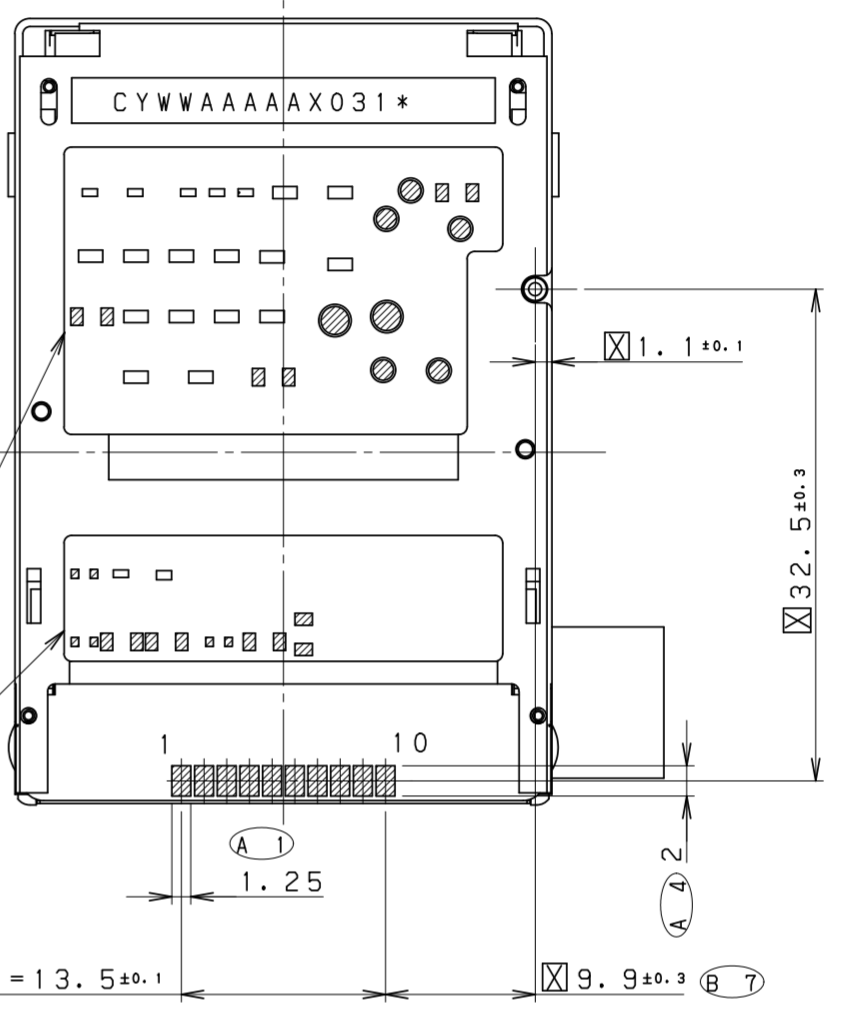
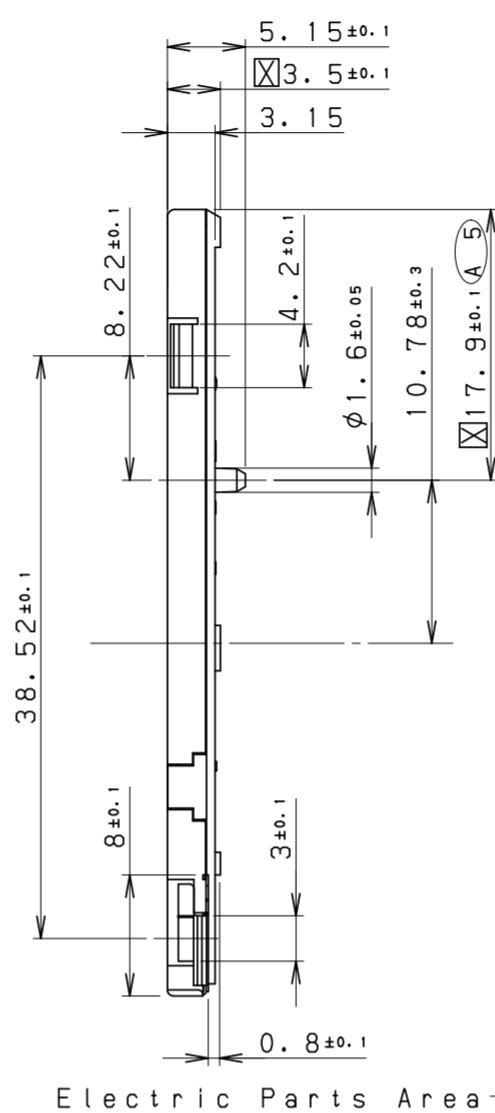
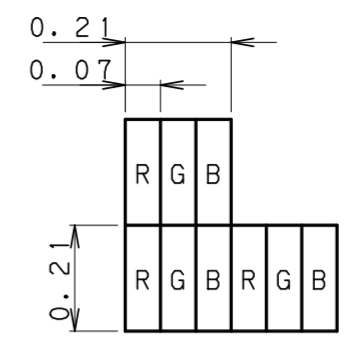

LCD I/F

Pin	Name
1	LCD_RS
2	LCD_RESET
3	LCD_CS
4	LCD_SYNC
5	LCD_CLK
6	LCD_DAT
7	VDD=2.9V
8	LCD_GND
9	LCD_LED_A
10	LCD_LED_C

DETAIL OF PRODUCT LABEL

CYWWAAAAAX031*

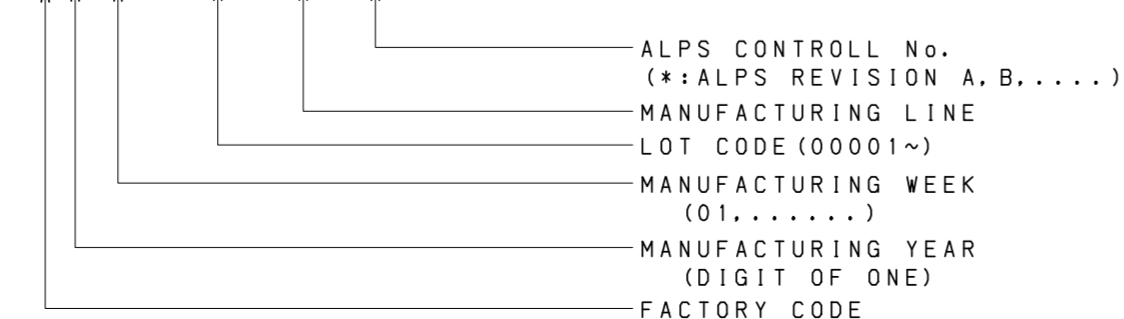

Tolerance list (一般公差表)

Dimension	Tolerance
L≤6	±0.25 (mm)
6<L≤18	±0.3 (mm)
18<L≤50	±0.4 (mm)
50<L≤125	±0.5 (mm)
125<L	±0.6 (mm)
ANGLE	±1' (DEG)

(B 4) 5) X marked dimensions are customer specified dimensions.
 (B 3) 4) Packing Specification based on No.D13-1524CG01A-2.
 3) Undescribed dimensional tolerances are shown by tolerance list.
 2) TFT LCD/Positive type.
 Note 1) 132x(RGB)x176 dots, Transflective Color, with B/L.

VARIETY NO.	MATERIAL NAME	MATERIAL NO.	NOTE
ALPS ELECTRIC CO., LTD.			
D 1	2005.04.22 S.T.T.A.T.N	DSGD.DEC., 27, 2004 T. NOZAKI	SCALE NUMBER 2 : 1 LPU4CG031B
C 2	2005.04.18 S.T.T.A.T.N	CHKD.DEC., 27, 2004 S. TAKANO	TITLE LCD MODULE
A 9	2005.01.18 S.T.T.A.T.N	APPD.DEC., 27, 2004 S. TAKANO	UNIT mm
SYMB	DATE	APPD	CHKD DSGD

Product Inspection Provision

Date : Dec., 14, '04

Model : LCD module

Registration No. : JL2076

ALPS ELECTRIC CO., LTD.
PERIPHERAL PRODUCTS DIVISION

Dec., 14, '04 QC.2 K.Seki	Dec., 14, '04 Eng.4 S.Takano	Dec., 14, '04 Eng.4 T.Nozaki
---------------------------------	------------------------------------	------------------------------------

HEAD OFFICE /

1-7 YUKIGAYA OTSUKA-CHO OTA-KU TOKYO 145 JAPAN

PERIPHERAL PRODUCTS DIVISION /

39-1 AZA SAKUHATA OYASAKU YOSHIMA-MACHI IWAKI-CITY FUKUSHIMA 970-11 JAPAN

CLASS NO.	TITLE Product inspection provision	DOCUMENT
	JL2076	(1/7)

Inspection Provision

1.Purpose

The LCD inspection provision provides outgoing inspection provision and its expected quality level based on our outgoing inspection of LCD modules which ALPS ELECTRIC Co., Ltd. produces.

2.Applicable Scope

The LCD inspection provision is applicable to the arrangement in regard to outgoing inspection and quality assurance after outgoing.

3.Outgoing Inspection Provision

Outgoing inspection is according to the products inspection manual.

3-1.Inspection Method

ANSI/ASQC Z1.4 LEVEL Regular inspection.

3-2.Inspection Standard

	Item		AQL(%)	Remarks
Major Defect	Dots	Opens, Shorts, Erroneous operation	0.25	Faults which substantially lower the practicality and the initial purpose difficult to achieve.
	Dimensions	External from dimensions	0.40	
	Solder appearance	Short Loose	0.25	
Minor Defect	Inside the glass	Black spots Orientation	0.65	Faults which appear to pose almost no obstacle to the practicality, effective use, and operation.
	Polarizing plate	Scratches, foreign matter,air bubbles, and peeling		
	Dots	Pinhole, deformation		
	Color tone	Color unevenness		
	Solder appearance	Cold solder Solder projections		
Total	-	-	1.00	-

							APPD. Dec.,14,'04	CHKD. Dec.,14,'04	DSGD. Dec.,14,'04
							QC.2	Eng.4	Eng.4
PAGE	SYMB.	DATE	CONTENTS	APPD.	CHKD.	DSGD.	K.Seki	S.Takano	T.Nozaki

CLASS NO.	TITLE Product inspection provision	DOCUMENT
	JL2076	(2/7)

3-3. Inspection Provisions

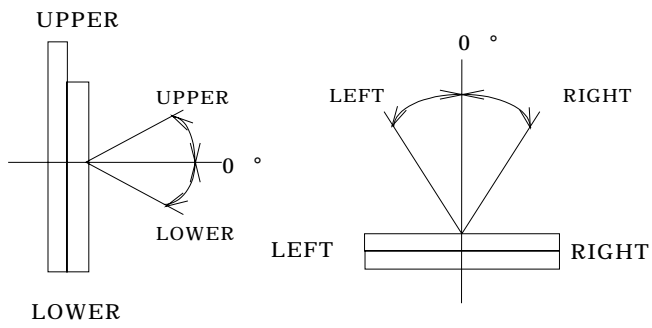
No.	Item	Measure
1	Illuminance	Inspection place to be 500 to 1000 lux illuminance uniformly without glaring. The light source should be daylight fluorescent lamp or cool white fluorescent lamp.
2	Distance	The distance between the eyes of the inspector and sample to be 30cm or more.
3	Viewing Direction	Measurement should be performed within the range as shown below.(and are based on the specification of product.) 

3-4 Viewing Area Definition

Fig.1

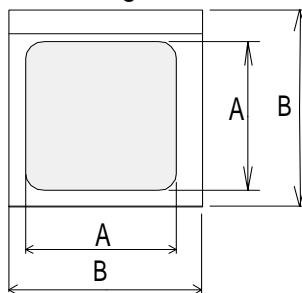

Cosmetic inspection should be applied only in the viewing area.(Zone A)

A : Zone Viewing Area

B : Zone Glass Plate Out Line

3-5 Limit sample

Mutually agreed limit samples should be used when the criteria is not suitable to specify with value.

In this case the limit samples have higher priority.

CLASS NO.	TITLE Product inspection provision	DOCUMENT
	JL2076	(3/7)

4.Specification for quality check

4-1.Electrical characteristics

No.	Item	Criteria
1.	Non operational	NO-GO
2.	Miss operating	NO-GO
3.	Missing dot	NO-GO
4.	Contrast irregular	Non detectable
5.	Response time	Non detectable
6.	LED backlight turn on/off	NO-GO

4-2.LCD active area appearance defect

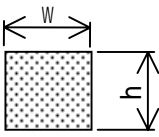
No.	Item	Criteria
1.	Thick and thin display	 <p>Taken to be within $\pm 15\%$ of display character width (w) and height (h).</p>

4-3.LCD rear surface (White reflector surface) cosmetic defect

(1) Black spot or colored spot (specified viewing area only)

D (long diameter) 0.25mm : OK

0.25mm<D : NG

(2) Bending line (specified vewing area only)

Not accept

CLASS NO.	TITLE Product inspection provision	DOCUMENT
	JL2076	(4/7)

4-4 Cosmetic defect (Active area)

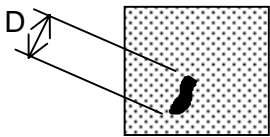
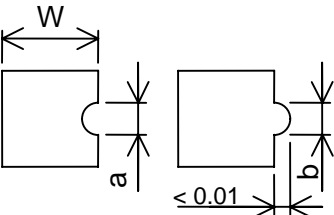
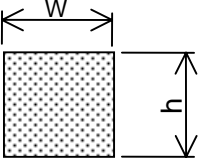
No.	Item	Criteria								
1	Pin hole	 <table border="1" data-bbox="837 481 1252 649"> <thead> <tr> <th>D(mm)</th> <th>Criteria</th> </tr> </thead> <tbody> <tr> <td>D 0.15</td> <td>Ignore</td> </tr> <tr> <td>0.15 < D 0.2</td> <td>1</td> </tr> <tr> <td>0.2 < D</td> <td>0</td> </tr> </tbody> </table>	D(mm)	Criteria	D 0.15	Ignore	0.15 < D 0.2	1	0.2 < D	0
D(mm)	Criteria									
D 0.15	Ignore									
0.15 < D 0.2	1									
0.2 < D	0									
2	Malformed Dots (1)	 <p>a, b 1/2 W Total: less than 10</p>								
3	Malformed Dots (2)	 <p>W or h +/- 15%</p>								

4-5. Cosmetic defects (Viewing area)

No.	Item	Criteria																						
1	Black spot, White spot	<p>(1) Spots</p> <table border="1" data-bbox="798 1243 1212 1444"> <thead> <tr> <th>D(mm)</th> <th>Criteria</th> </tr> </thead> <tbody> <tr> <td>D 0.1</td> <td>Ignore</td> </tr> <tr> <td>0.1 < D 0.15</td> <td>2</td> </tr> <tr> <td>0.15 < D 0.2</td> <td>1</td> </tr> <tr> <td>0.2 < D</td> <td>0</td> </tr> </tbody> </table> <p>(2) Line</p> <table border="1" data-bbox="798 1467 1404 1657"> <thead> <tr> <th>Width (mm)</th> <th>Length(mm)</th> <th>Criteria</th> </tr> </thead> <tbody> <tr> <td>W 0.02</td> <td>Ignore</td> <td>Ignore</td> </tr> <tr> <td>0.02 < W 0.04</td> <td>L 3</td> <td>1</td> </tr> <tr> <td>0.04 < W</td> <td>3 < L</td> <td>0</td> </tr> </tbody> </table>	D(mm)	Criteria	D 0.1	Ignore	0.1 < D 0.15	2	0.15 < D 0.2	1	0.2 < D	0	Width (mm)	Length(mm)	Criteria	W 0.02	Ignore	Ignore	0.02 < W 0.04	L 3	1	0.04 < W	3 < L	0
D(mm)	Criteria																							
D 0.1	Ignore																							
0.1 < D 0.15	2																							
0.15 < D 0.2	1																							
0.2 < D	0																							
Width (mm)	Length(mm)	Criteria																						
W 0.02	Ignore	Ignore																						
0.02 < W 0.04	L 3	1																						
0.04 < W	3 < L	0																						
2	Scratch, Dents	Same as above spots and line																						
3	Air bubble between glass and polarizer	<table border="1" data-bbox="798 1736 1212 1915"> <thead> <tr> <th>D (mm)</th> <th>Criteria</th> </tr> </thead> <tbody> <tr> <td>D 0.15</td> <td>Ignore</td> </tr> <tr> <td>0.1 < D 0.3</td> <td>1</td> </tr> <tr> <td>0.3 < D</td> <td>0</td> </tr> </tbody> </table>	D (mm)	Criteria	D 0.15	Ignore	0.1 < D 0.3	1	0.3 < D	0														
D (mm)	Criteria																							
D 0.15	Ignore																							
0.1 < D 0.3	1																							
0.3 < D	0																							

CLASS NO.	TITLE Product inspection provision	DOCUMENT
	JL2076	(5/7)

4-6. General appearance defect

No.	Item	Criteria	
1.	Chippings and cracks	(1-1) General chipping of LCD 	$c = t$ $b \leq 1 \text{ mm}$ $a \leq 3 \text{ mm}$ d should not reach the seal area. Total acceptable quantity for 1-1 and 1-2 is 5 pieces maximum. Where, a and b are ignored when it is 0.5mm or less.
		(1-2) General chipping of LCD 	$c < t$ $b \leq 1 \text{ mm}$ $a \leq 3 \text{ mm}$ $d = 0 \text{ mm}$ Total acceptable quantity for 1-1 and 1-2 is 5 pieces maximum. Where, a and b are ignored when it is 0.5mm or less.
		(2) General chipping of LCD 	$c < t$ $b = 0 \text{ mm}$ $a \leq 5 \text{ mm}$ d should not reach the seal area.
		(3) Corner crack of LCD 	$a \leq 2 \text{ mm}$ $b \leq 2 \text{ mm}$ $c \leq t$ It should not reach the alignment mark.
		(4) chipping of contact ledge 	$a \leq 3 \text{ mm}$ $b \leq 0.5 \text{ mm}$ $c \leq t$ It should not reach the alignment mark.
		(5) chipping on the rear of contact ledge 	$a \leq 3 \text{ mm}$ $b \leq 1 \text{ mm}$ $c \leq t/2$
	(6) Spreadable crack	NG	

CLASS NO.	TITLE Product inspection provision	DOCUMENT
	JL2076	(6/7)

5.Symbolization

5-1.Production Lot No.

Product No.		Inspection stamp
Quantity		
Lot No.	○ ○ ○ ○ ○ ○ ○ ○ ○ ○	

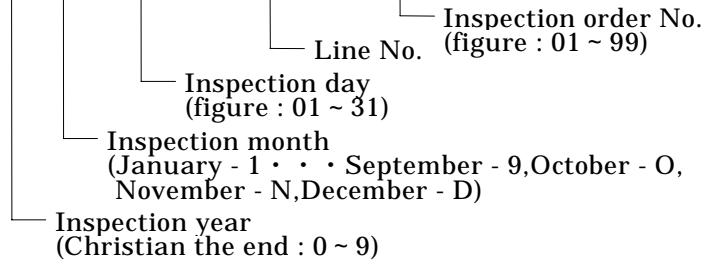

6.Revision and abolition of specifications

If any doubt about this specification arises, it shall be revised or abolished according to the agreement between the parties in volleyed.

7. MATTERS THAT REQUIRE ATTENTION WHEN YOU USE THE PRODUCT

7-1. Follow the directions/cautions below when you use the product.

- (1)The LSI used is very sensitive to static electricity. Discharge the static electricity on the human body or clothes with a resistor of approx. 1 kilo-ohm before you use the product.
- (2)Put on insulating finger-stalls so that the product surface won't be stained.

7-2 CAUTIONS FOR SAFETY

If the liquid crystal flows out when the product is broken, neither lick nor absorb it.
 If the liquid crystal touches your hand or skin, wash it away completely.

CLASS NO.	TITLE Product inspection provision	DOCUMENT
	JL2076	(7/7)

7-3 DIRECTIONS FOR INSTALLATION

- (1) When you mount this product, take most care not to push hard on the display surface with your fingers. It may cause mal-functions or shorten the life of the product.
- (2) Do not bend or twist the product for installation.
- (3) If you apply the voltage beyond the specified range, the product may deteriorate sooner than spec. Keep to the proper voltage range, and take special care when you use the product at high temperatures.

7-4. DIRECTIONS FOR OPERATION

- (1) If you have bedewing on the module when you test the product, dry it up before restart operation. Bedewing may cause mal-functions.
- (2) If the operation temperature becomes below the specified range, LCD response will be slow and if the temperature become higher than the specified range, the display will be darkened overall. When the temperature returns to the specified range, both phenomena will disappear.

7-5 DIRECTIONS FOR STORAGE

- (1) Do not store the product for a long period in the environment with high temperatures and high humidity. If you need to store it for a long period, choose a place with the temperatures from 5 to 25 and low humidity.
- (2) Do not leave the product under the direct sunlight or the fluorescent light for a long time.
- (3) If you store the product for a week or longer, put it in the carton of ALPS before storing it.