

Feature

- 40V,30A
 $R_{DS(ON)} < 9.3m\Omega @ V_{GS}=10V$ TYP:7.4 m Ω
 $R_{DS(ON)} < 14.3m\Omega @ V_{GS}=4.5V$ TYP:10.4 m Ω
- Advanced Trench Technology
- Lead free product is acquired
- Excellent $R_{DS(ON)}$ and Low Gate Charge

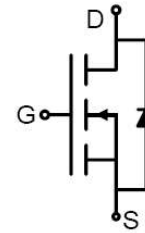

Schematic Diagram

Application

- PWM applications
- Load Switch
- Power management

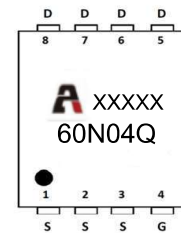

Marking and pin Assignment

Package Marking and Ordering Information

Device Marking	Device	Device Package	Reel Size	Tape width	Quantity (PCS)
60N04Q	AP60N04Q	PDFN3X3-8L	13 inch	-	5000

ABSOLUTE MAXIMUM RATINGS ($T_a=25^{\circ}C$ unless otherwise noted)

Parameter	Symbol	Value	Unit
Drain-Source Voltage	V_{DS}	40	V
Gate-Source Voltage	V_{GS}	± 20	V
Continuous Drain Current ($T_a=25^{\circ}C$)	I_D	30	A
Continuous Drain Current ($T_a=100^{\circ}C$)	I_D	19	A
Pulsed Drain Current ⁽¹⁾	I_{DM}	120	A
Singel Pulsed Avalanche Energy ⁽²⁾	E_{AS}	101	mJ
Power Dissipation	P_D	56	W
Thermal Resistance from Junction to Case ⁽⁴⁾	$R_{\theta JC}$	2.723	$^{\circ}C/W$
Junction Temperature	T_J	150	$^{\circ}C$
Storage Temperature	T_{STG}	-55~ +150	$^{\circ}C$

MOSFET ELECTRICAL CHARACTERISTICS($T_a=25^{\circ}\text{C}$ unless otherwise noted)

Parameter	Symbol	Test Condition	Min	Type	Max	Unit
Static Characteristics						
Drain-source breakdown voltage	$V_{(BR)DSS}$	$V_{GS} = 0V, I_D = 250\mu A$	40	-	-	V
Zero gate voltage drain current	I_{DSS}	$V_{DS} = 40V, V_{GS} = 0V$	-	-	1	μA
Gate-body leakage current	I_{GSS}	$V_{GS} = \pm 20V, V_{DS} = 0V$	-	-	± 100	nA
Gate threshold voltage ⁽³⁾	$V_{GS(th)}$	$V_{DS} = V_{GS}, I_D = 250\mu A$	1	1.6	2.5	V
Drain-source on-resistance ⁽³⁾	$R_{DS(on)}$	$V_{GS} = 10V, I_D = 30A$	-	7.4	9.3	m Ω
		$V_{GS} = 4.5V, I_D = 10A$	-	10.4	14.3	
Dynamic characteristics						
Input Capacitance	C_{iss}	$V_{DS} = 20V, V_{GS} = 0V, f = 1MHz$	-	1570	-	pF
Output Capacitance	C_{oss}		-	132	-	
Reverse Transfer Capacitance	C_{rss}		-	115	-	
Switching characteristics						
Turn-on delay time	$t_{d(on)}$	$V_{DD} = 20V, I_D = 25A, R_L = 4.7\Omega$ $V_{GS} = 10V, R_G = 1\Omega$	-	3.6	-	ns
Turn-on rise time	t_r		-	9.6	-	
Turn-off delay time	$t_{d(off)}$		-	24	-	
Turn-off fall time	t_f		-	9.6	-	
Total Gate Charge	Q_g	$V_{DS} = 20V, I_D = 25A,$ $V_{GS} = 10V$	-	32.5	-	nC
Gate-Source Charge	Q_{gs}		-	4.5	-	
Gate-Drain Charge	Q_{gd}		-	5.6	-	
Source-Drain Diode characteristics						
Diode Forward voltage ⁽³⁾	V_{DS}	$V_{GS} = 0V, I_S = 10A$	-	-	1.2	V
Diode Forward current ⁽⁴⁾	I_S		-	-	30	A
Body Diode Reverse Recovery Time	t_{rr}	$T_J = 25^{\circ}, I_F = 30A, di/dt = 100A/\mu s$		11		ns
Body Diode Reverse Recovery Charge	Q_{rr}	$T_J = 25^{\circ}, I_F = 30A, di/dt = 100A/\mu s$		6		nc

Notes:

1. Repetitive Rating: pulse width limited by maximum junction temperature
2. EAS Condition: $T_J = 25^{\circ}\text{C}, V_{DD} = 20V, R_G = 25\Omega, L = 0.5\text{mH}$
3. Pulse Test: pulse width $\leq 300\mu s$, duty cycle $\leq 2\%$
4. Surface Mounted on FR4 Board, $t \leq 10\text{ sec}$

Test Circuit & Waveform

Gate Charge Test Circuit & Waveform

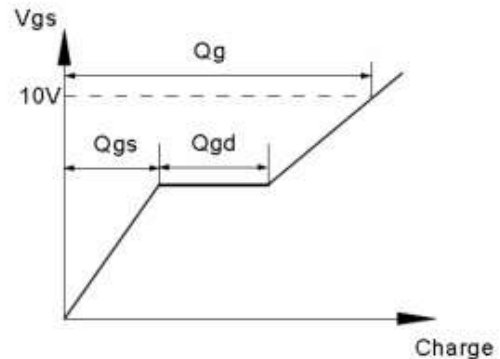
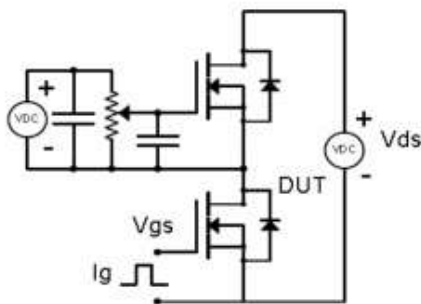

Resistive Switching Test Circuit & Waveforms

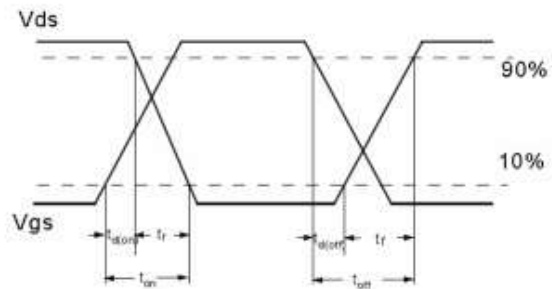
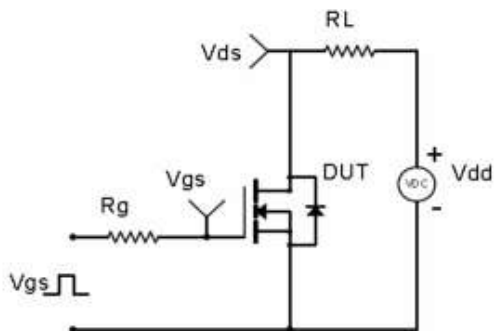

Unclamped Inductive Switching (UIS) Test Circuit & Waveforms

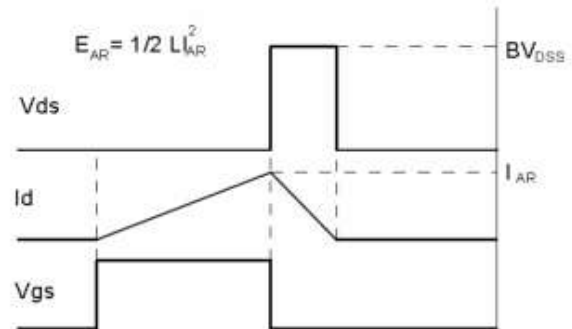
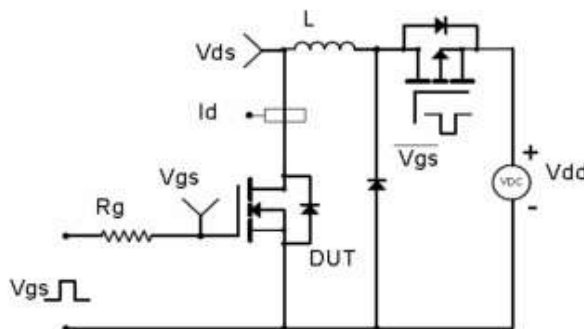

Diode Recovery Test Circuit & Waveforms

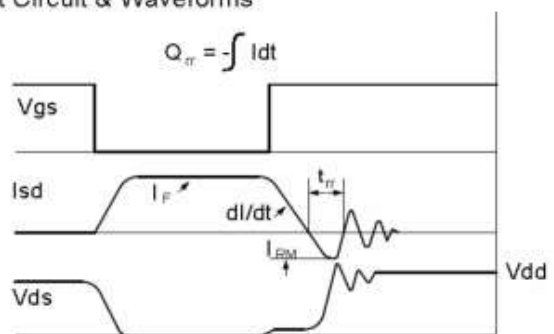
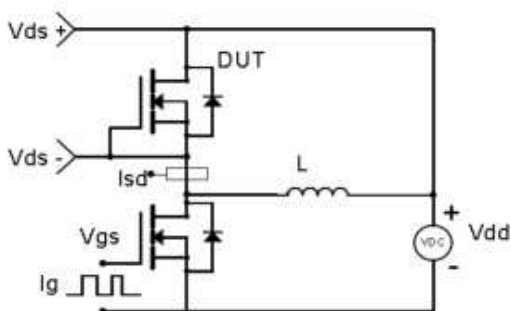

Fig.1 Power Dissipation Derating Curve

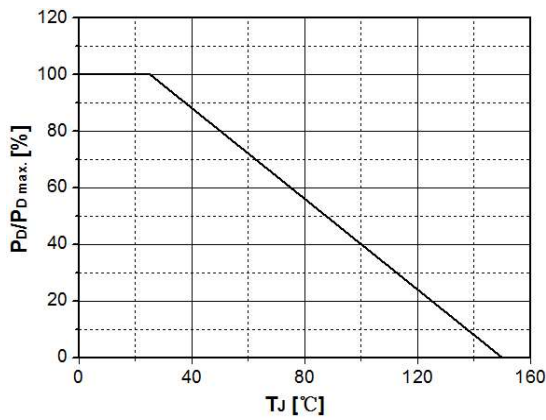

Fig.2 Avalanche Energy Derating Curve vs. Junction Temperature

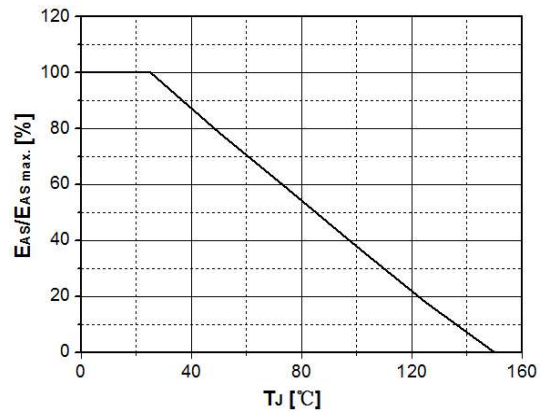

Fig.3 Typical Output Characteristics

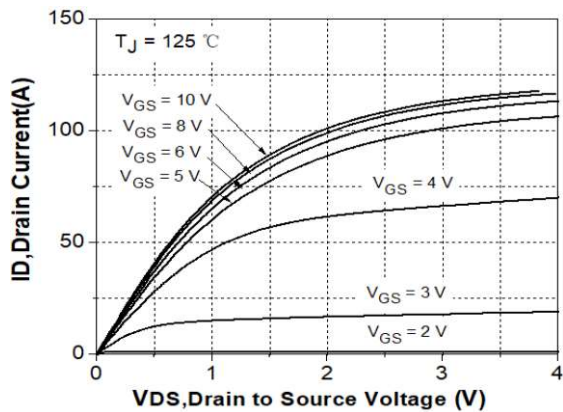

Fig. 4 Transconductance vs. Drain Current

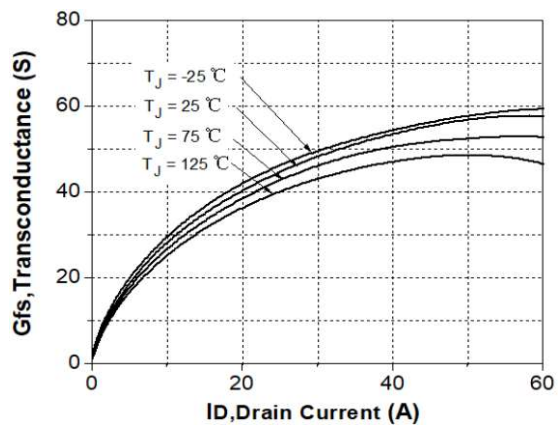

Fig.5 Typical Transfer Characteristics

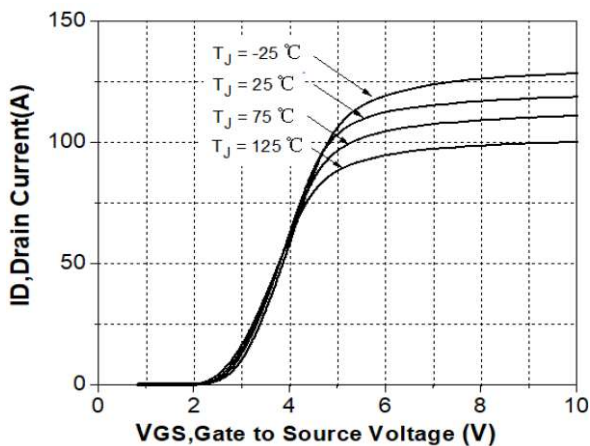

Fig. 6 State Resistance vs. Drain Current @-25°C

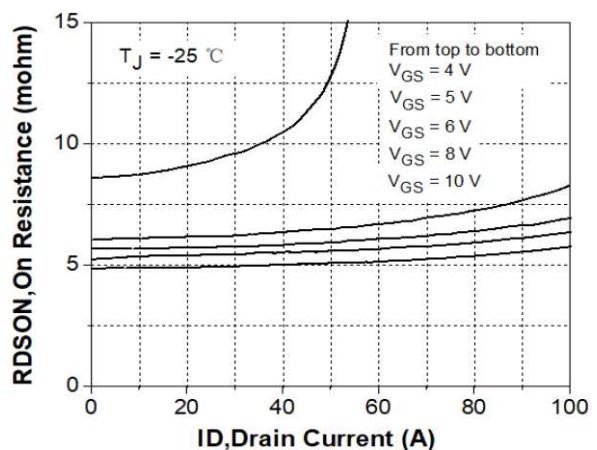

Fig.7 State Resistance vs. Drain Current @25°C

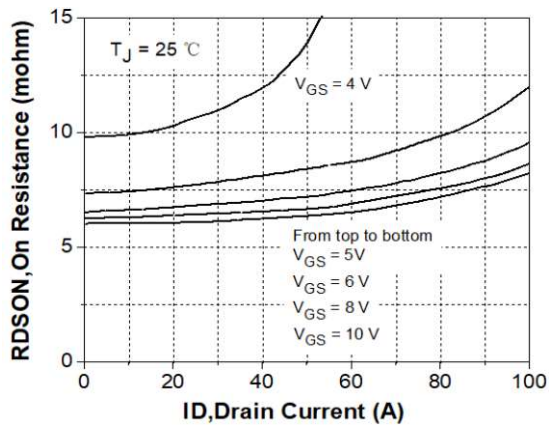

Fig. 8 State Resistance vs. Drain Current @125°C

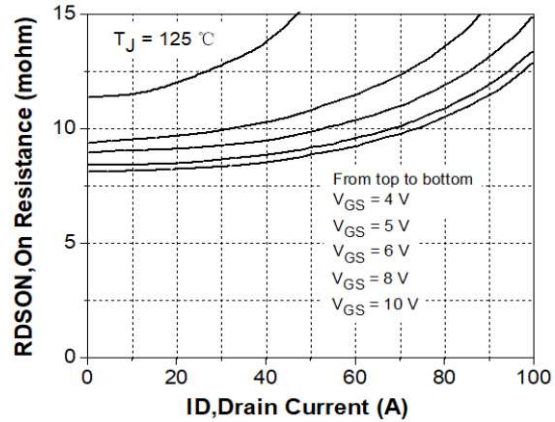

Fig.9 Typical Capacitance vs. Drain Source Voltage

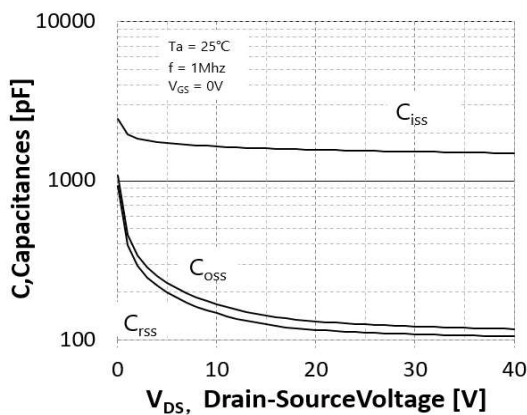

Fig.10 Dynamic Input Characteristics

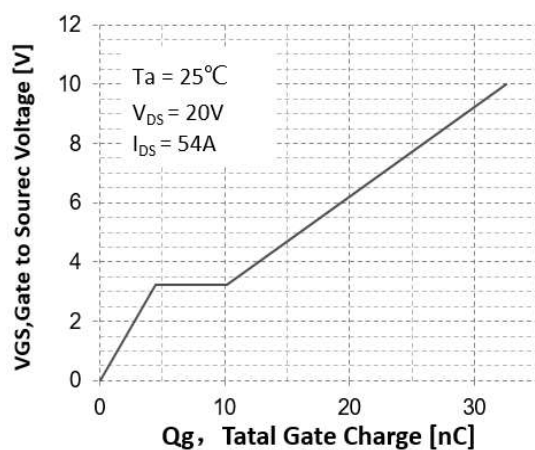

Fig.11 Breakdown Voltage vs. Junction Temperature

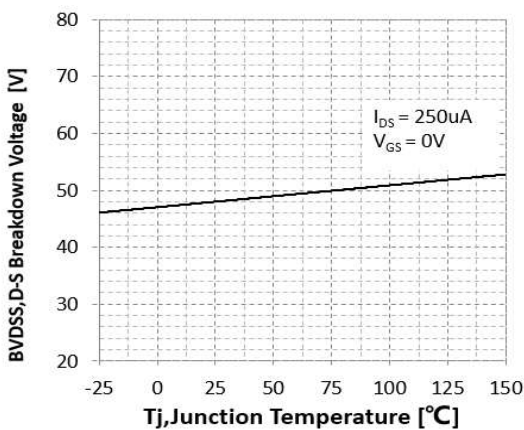

Fig. 12 Gate Threshold Voltage vs. Junction Temperature

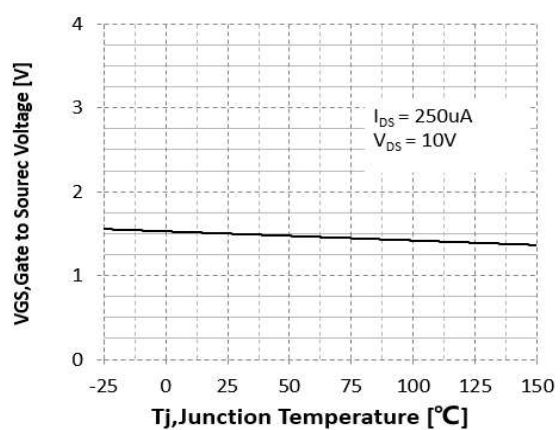

Fig.13 On-Resistance Variation vs. Junction Temperature

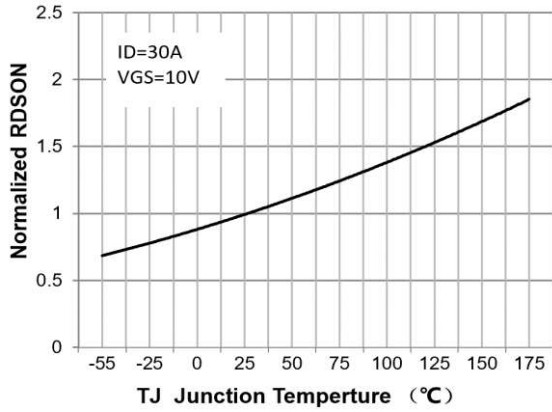

Fig.14 Maximum Drain Current vs. Case Temperature

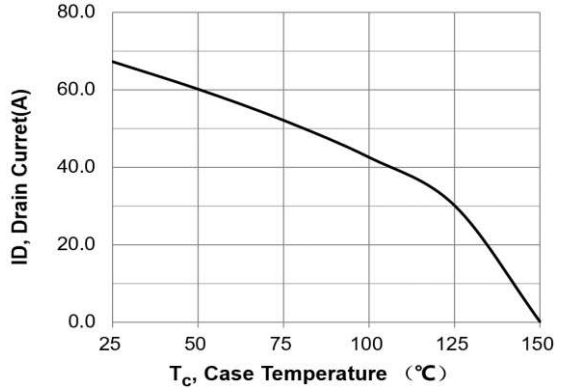

Fig.15 Body Diode Forward Voltage Vs Reverse Drain Current

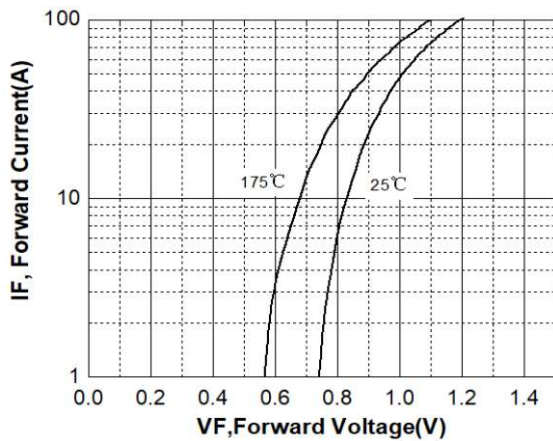

Fig.16 Safe Operating Area

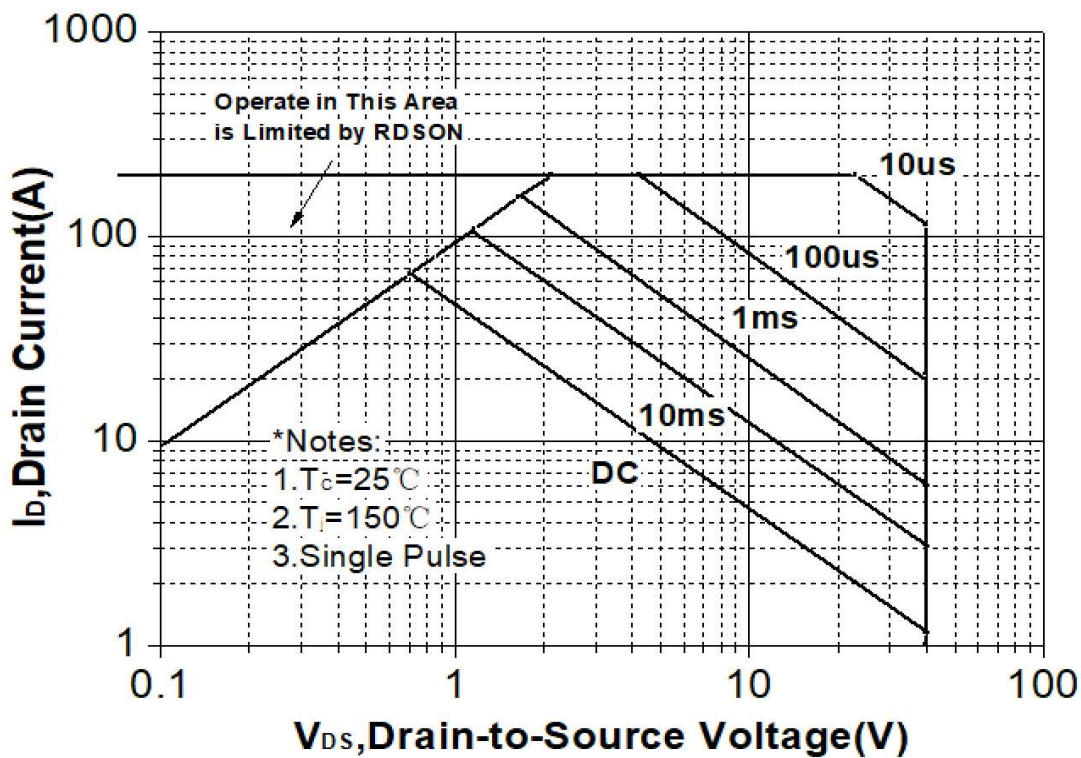
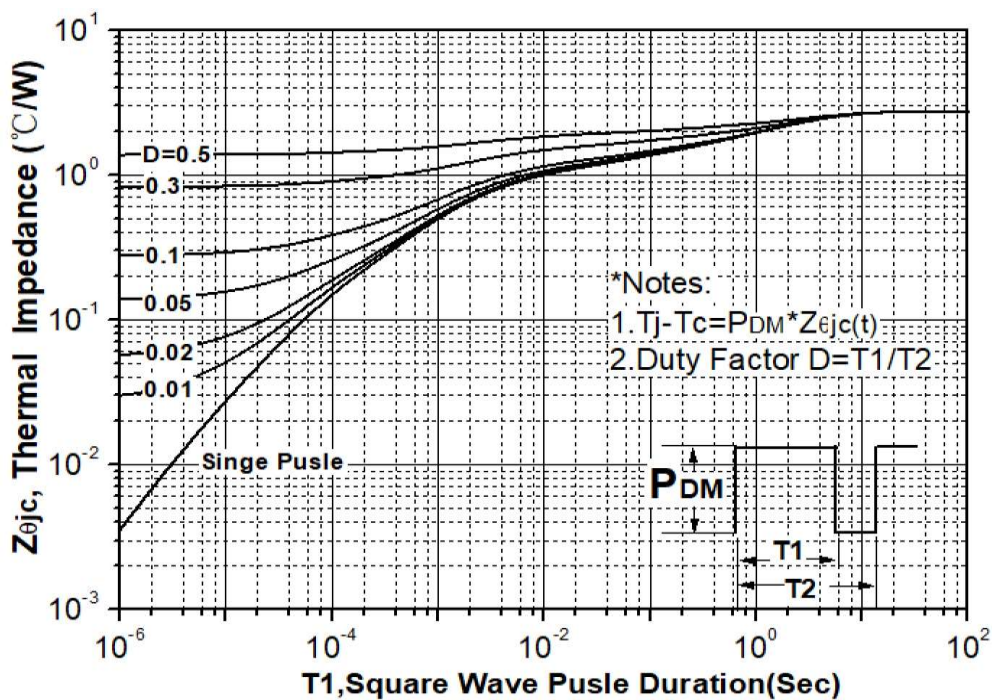
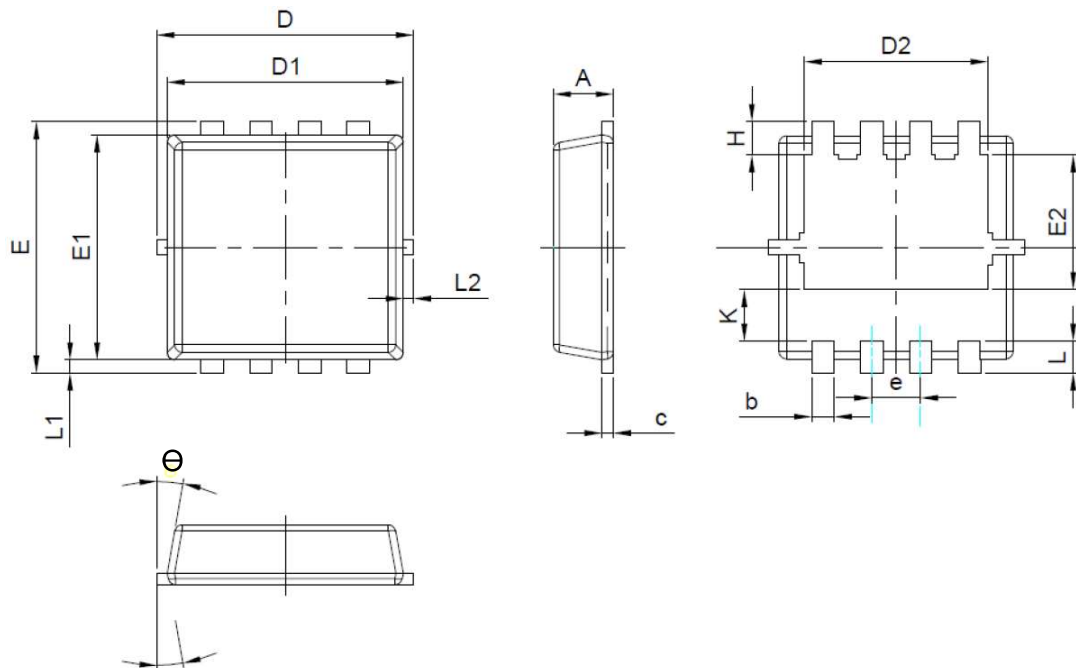

Fig. 17 Transient Thermal Response Curve



PDFN3X3-8L Package Information



COMMON DIMENSIONS
(UNITS OF MEASURE = MILLIMETER)

SYMBOL	MIN	NOM	MAX
A	0.70	0.80	0.90
b	0.25	0.30	0.39
c	0.14	0.15	0.25
D	3.20	3.30	3.40
D1	3.00	3.15	3.30
D2	2.35	2.45	2.55
e	0.65 BSC		
E	3.25	3.35	3.45
E1	2.85	3.00	3.15
E2	1.635	1.735	1.835
H	0.33	0.48	0.63
K	0.585	0.685	0.785
L	0.30	0.40	0.50
L1	0.05	0.15	0.25
L2	-	-	0.15
θ	8°	10°	12°