

8-Bit Shift Registers With 3-State Output

1 FEATURES

- 8-bit serial input, parallel output shift
- Serial Output (Q7S)
- Power-Supply Range: 2V to 5.5V
- Low power consumption: 160 μ A(Max)
- Low input current: 1 μ A(Max)
- Shift register has direct clear
- Storage register with 3-state outputs
- Extended Temperature: -40°C to +125°C

2 APPLICATIONS

- Enterprise and communications
- Industrial
- Personal electronics
- LED displays
- Servers

3 DESCRIPTIONS

RS595S is an 8-bit serial-in/serial or parallel-out shift register with a storage register and 3-state outputs. Separate clocks are provided for both the shift register and storage register. The shift register has an asynchronous reset (\overline{MR}) input, serial (SER) input, and serial outputs (Q7S) for cascading. A low on \overline{MR} will clear the shift register. Data is shifted on the LOW-to-HIGH transitions of the SRCLK input. The data in the shift register is transferred to the storage register on a LOW-to-HIGH transition of the RCLK input. If both clocks are connected together, the shift register will always be one clock pulse ahead of the storage register. Data in the storage register appears at the output whenever the output enable input (\overline{OE}) is Low. A High on \overline{OE} causes the outputs to assume a high-impedance OFF-state. Operation of the \overline{OE} input does not affect the state of the registers.

Device Information ⁽¹⁾

PART NUMBER	PACKAGE	BODY SIZE (NOM)
RS595S	TSSOP-16	5.00mmx4.40mm
	SOIC-16(SOP16)	9.90mmx3.90mm
	QFN2.5x3.5-16L	2.50mmx3.50mm

(1) For all available packages, see the orderable addendum at the end of the data sheet.

4 Functional Block Diagram

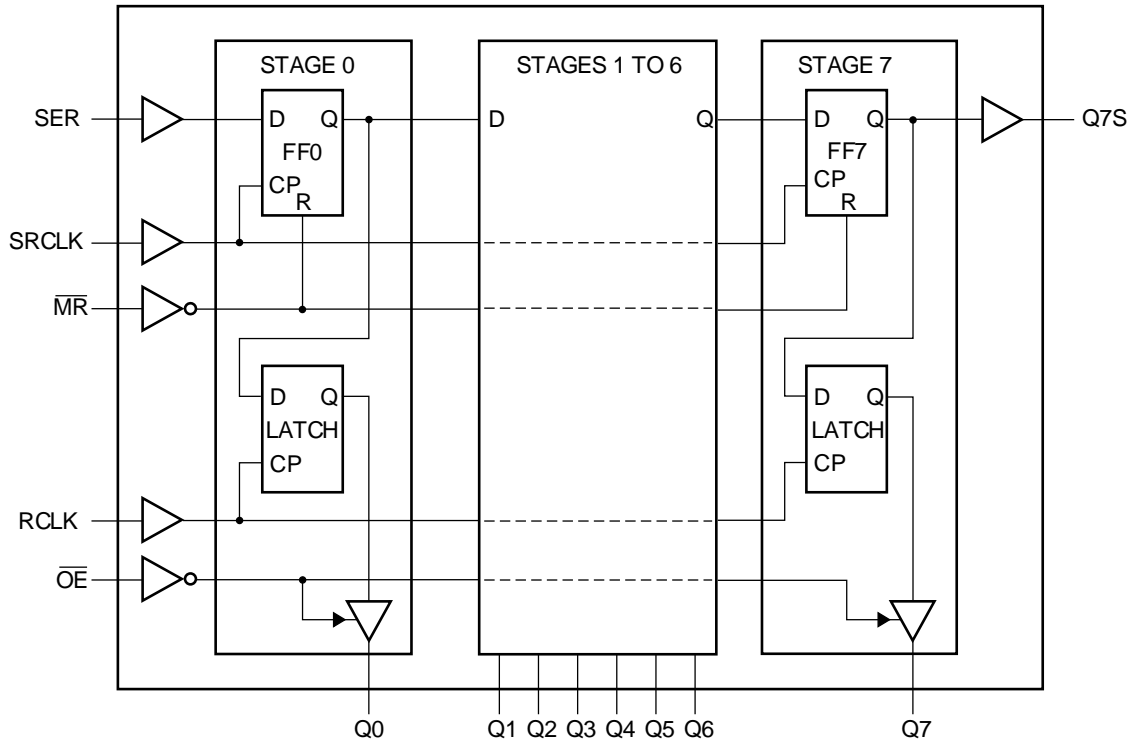

Table of Contents

1 FEATURES	1
2 APPLICATIONS	1
3 DESCRIPTIONS	1
4 Functional Block Diagram	2
5 Revision History	4
6 PACKAGE/ORDERING INFORMATION ⁽¹⁾	5
7 PIN CONFIGURATIONS	6
8 Functional description ⁽¹⁾	7
8.1 TIMING DIAGRAM	7
9 SPECIFICATIONS	8
9.1 Absolute Maximum Ratings	8
9.2 ESD Ratings	8
9.3 Recommended Operating Conditions	9
9.4 ELECTRICAL CHARACTERISTICS	10
9.5 Switching Characteristics	11
9.6 Operating Characteristics	11
10 Parameter Measurement Information	12
11 PACKAGE OUTLINE DIMENSIONS	15
12 TAPE AND REEL INFORMATION	18

5 Revision History

Note: Page numbers for previous revisions may differ from page numbers in the current version.

VERSION	Change Date	Change Item
A.1	2022/11/01	Initial version completed

6 PACKAGE/ORDERING INFORMATION ⁽¹⁾

PRODUCT	ORDERING NUMBER	TEMPERATURE RANGE	PACKAGE LEAD	PACKAGE MARKING ⁽²⁾	MSL ⁽³⁾	PACKAGE OPTION
RS595S	RS595SXTSS16	-40°C ~+125°C	TSSOP-16	RS595	MSL3	Tape and Reel,4000
	RS595SXS16	-40°C ~+125°C	SOIC-16(SOP16)	RS595	MSL3	Tape and Reel,4000
	RS595SXTQC16	-40°C ~+125°C	QFN2.5x3.5-16L	RS595	MSL3	Tape and Reel,5000

NOTE:

- (1) This information is the most current data available for the designated devices. This data is subject to change without notice and revision of this document. For browser-based versions of this data sheet, refer to the right-hand navigation.
- (2) There may be additional marking, which relates to the lot trace code information (data code and vendor code), the logo or the environmental category on the device.
- (3) MSL, The Moisture Sensitivity Level rating according to the JEDEC industry standard classifications.

7 PIN CONFIGURATIONS

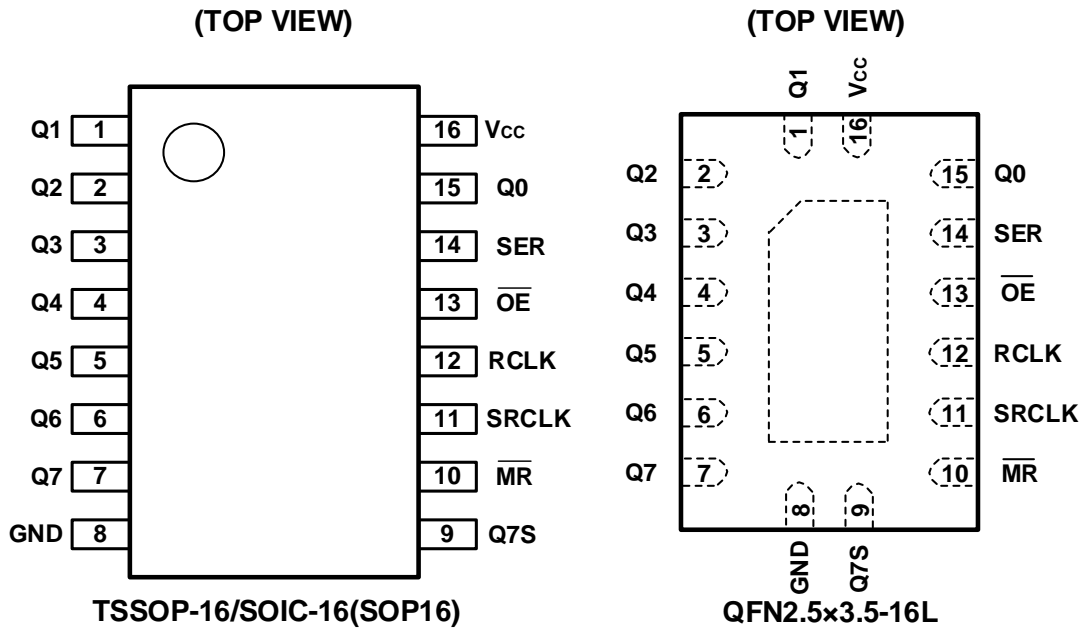

PIN DESCRIPTION

PIN	NAME	TYPE ⁽¹⁾	FUNCTION
1~7	Q1~Q7	O	Parallel data output
8	GND	G	Ground.
9	Q7S	O	Serial data output
10	$\overline{\text{MR}}$	I	Master reset (active Low)
11	SRCLK	I	Shift register clock input
12	RCLK	I	Storage register clock input
13	$\overline{\text{OE}}$	I	Output enable input (active Low)
14	SER	I	Serial data input
15	Q0	I	Parallel data output
16	V _{cc}	P	Supply voltage

(1) I=input, O=output, P=power, G=Ground.

8 Functional description ⁽¹⁾

CONTROL				INPUT	OUTPUT		FUNCTION
SRCLK	RCLK	\overline{OE}	\overline{MR}	SER	Q7S	Qn	
X	X	L	L	X	L	NC	a Low-level on \overline{MR} only affects the shift registers
X	↑	L	L	X	L	L	empty shift register loaded into storage register
X	X	H	L	X	L	Z	shift register clear; parallel outputs in high-impedance OFF-state
↑	X	L	H	H	Q6S	NC	logic High-level shifted into shift register stage 0. Contents of all shift register stages shifted through, e.g. previous state of stage 6 (internal Q6S) appears on the serial output (Q7S).
X	↑	L	H	X	NC	QnS	contents of shift register stages (internal QnS) are transferred to the storage register and parallel output stages
↑	↑	L	H	X	Q6S	QnS	contents of shift register shifted through; previous contents of the shift register is transferred to the storage register and the parallel output stages

- (1) H = HIGH voltage state;
 L = LOW voltage state;
 ↑ = LOW-to-HIGH transition;
 X = don't care;
 NC = no change;
 Z = high-impedance OFF-state.

8.1 TIMING DIAGRAM

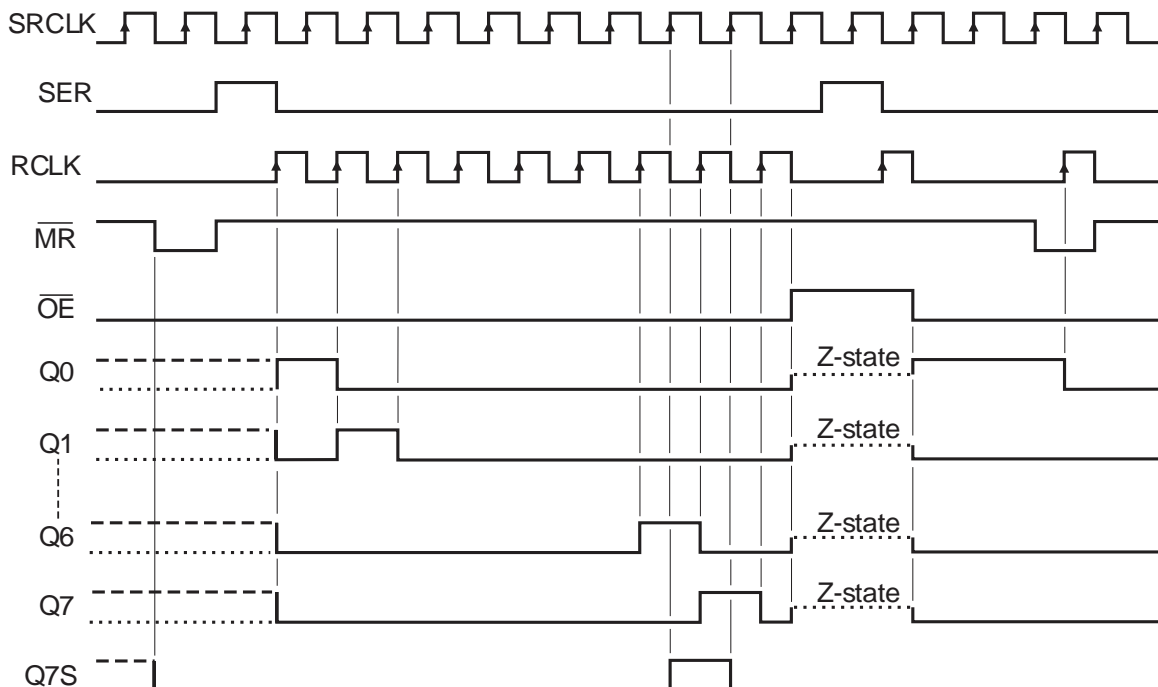

9 SPECIFICATIONS

9.1 Absolute Maximum Ratings

Over operating free-air temperature range (unless otherwise noted) ⁽¹⁾

SYMBOL	PARAMETER	CONDITION	MIN	MAX	UNIT
V _{CC}	Supply Voltage Range		0	6.5	V
I _{IK}	Input Clamp Current	V _I < -0.5 V or V _I > V _{CC} + 0.5 V		±20	mA
I _{OK}	Output Clamp Current	V _O < -0.5V or V _O > V _{CC} +0.5V		±20	mA
I _O	Output Current	V _O =-0.5V to (V _{CC} +0.5V)			
		Pin Q7S		±25	mA
		Pin Qn		±35	mA
I _{CC}	Supply Current			70	mA
I _{GND}	Ground Current		-70		mA
θ _{JA}	Package thermal impedance ⁽²⁾	TSSOP-16		45	°C/W
		SOIC-16(SOP16)		150	
T _J	Junction Temperature ⁽³⁾		-40	150	°C
T _{stg}	Storage Temperature		-65	150	

(1) Stresses beyond those listed under *Absolute Maximum Ratings* may cause permanent damage to the device. These are stress ratings only, which do not imply functional operation of the device at these or any other conditions beyond those indicated under *Recommended Operating Conditions*. Exposure to absolute-maximum-rated conditions for extended periods may affect device reliability.

(2) The package thermal impedance is calculated in accordance with JEDEC-51.

(3) The maximum power dissipation is a function of T_{J(MAX)}, R_{θJA}, and T_A. The maximum allowable power dissipation at any ambient temperature is P_D = (T_{J(MAX)} - T_A) / R_{θJA}. All numbers apply for packages soldered directly onto a PCB.

9.2 ESD Ratings

The following ESD information is provided for handling of ESD-sensitive devices in an ESD protected area only.

			VALUE	UNIT
V _(ESD)	Electrostatic discharge	Human-Body Model (HBM), per ANSI/ESDA/JEDEC JS-001 ⁽¹⁾	±4000	V
		Charged-Device Model (CDM), per ANSI/ESDA/JEDEC JS-002 ⁽²⁾	±1500	
		Machine Model (MM)	±400	

(1) JEDEC document JEP155 states that 500 V HBM allows safe manufacturing with a standard ESD control process.

(2) JEDEC document JEP157 states that 250 V CDM allows safe manufacturing with a standard ESD control process.



ESD SENSITIVITY CAUTION

ESD damage can range from subtle performance degradation to complete device failure. Precision integrated circuits may be more susceptible to damage because very small parametric changes could cause the device not to meet its published specifications.

9.3 Recommended Operating Conditions

Voltages are reference to GND(0V).

PARAMETER	SYMBOL	TEST CONDITIONS	MIN	TYP	MAX	UNIT
Supply voltage	V_{CC}		2		5.5	V
High-level input voltage	V_{IH}	$V_{CC}=2.0V$	1.50			V
		$V_{CC}=4.5V$	3.15			
		$V_{CC}=5.5V$	3.85			
Low-level input voltage	V_{IL}	$V_{CC}=2.0V$			0.50	V
		$V_{CC}=4.5V$			1.35	
		$V_{CC}=5.5V$			1.65	
Input voltage	V_I		0		V_{CC}	V
Output voltage	V_O		0		V_{CC}	V
Input transition rise or fall rate($\Delta t/\Delta v$)	Data inputs	$V_{CC}=2.0V$			625	ns/V
		$V_{CC}=4.5V$			139	
		$V_{CC}=5.5V$			83	
Operating temperature	T_A		-40		125	°C

9.4 ELECTRICAL CHARACTERISTICS

over recommended operating free-air temperature range (unless otherwise noted)

PARAMETER		TEST CONDITIONS	V _{CC}	TEMP	MIN ⁽¹⁾	TYP ⁽²⁾	MAX ⁽¹⁾	UNIT	
V _{OH}	all outputs							V	
	I _O = -20 μA		2.0 V	FULL	1.9				
			4.5V		4.4				
			5.5V		5.4				
	Q7S output								
	I _O = -4 mA		4.5V	FULL	3.7				
	I _O = -5.2 mA		5.5V		4.7				
	Qn bus driver outputs								
	I _O = -6 mA		4.5V	FULL	3.7				
I _O = -7.8 mA		5.5V	4.7						
V _{OL}	all outputs							V	
	I _O = 20 μA		2.0 V	FULL			0.1		
			4.5V				0.1		
			5.5V				0.1		
	Q7S output								
	I _O = 4 mA		4.5V	FULL			0.4		
	I _O = 5.2 mA		5.5V				0.4		
	Qn bus driver outputs								
	I _O = 6 mA		4.5V	FULL			0.4		
I _O = -7.8 mA		5.5V				0.4			
I _I	input leakage Current	V _I =V _{CC} or GND	5.5V	FULL			±1	μA	
I _{OZ}	OFF-state output current	V _I =V _{IH} or V _{IL} ; V _O =V _{CC} or GND	5.5V	FULL			±10		
I _{CC}	supply current	V _I =V _{CC} or GND; I _O =0A	5.5V	FULL			160		
C _I	input capacitance	V _I =V _{CC} or GND	3.3V	FULL		3.5	pF		

(1) Limits are 100% production tested at 25°C. Limits over the operating temperature range are ensured through correlations using statistical quality control (SQC) method.

(2) Typical values represent the most likely parametric norm as determined at the time of characterization. Actual typical values may vary over time and will also depend on the application and configuration.

9.5 Switching Characteristics

over recommended operating free-air temperature range, Full=-40°C to 125°C. ⁽¹⁾

PARAMETER	-40°C to +125°C									UNIT
	V _{CC} =2.0V ⁽²⁾			V _{CC} =4.5V ⁽²⁾			V _{CC} =5.5V ⁽²⁾			
	MIN	TYP ⁽³⁾	MAX	MIN	TYP ⁽³⁾	MAX	MIN	TYP ⁽³⁾	MAX	
Propagation delay, t _{pd} ⁽⁴⁾ SRCLK to Q7S			42			18			16	ns
Propagation delay, t _{pd} RCLK to Qn			40			18			18	ns
High to Low propagation, \overline{MR} to Q7S, t _{PHL} ⁽⁵⁾			28			14			10	ns
Enable time, t _{en} ⁽⁶⁾ \overline{OE} to Qn			36			16			12	ns
Disable time, t _{dis} ⁽⁷⁾ \overline{OE} to Qn			50			41			38	ns
Pulse width, t _w SRCLK High or Low	110			22			19			ns
Pulse width, t _w RCLK High or Low	110			22			19			ns
Pulse width, t _w \overline{MR} Low	110			22			19			ns
Hold width, t _h SER to SRCLK	3			3			3			ns
Set-up time, t _{su} SER to SRCLK	75			15			13			ns
Set-up time, t _{su} SRCLK to RCLK	110			22			19			ns
Recovery time t _{rec} MR to SRCLK	75			15			13			ns
Maximum frequency f _{max} SRCLK/RCLK C _L =15pF	4			20			24			MHz

(1) All unused inputs of the device must be held at V_{CC} or GND to ensure proper device operation.

(2) This parameter is ensured by design and/or characterization and is not tested in production.

(3) Typical values are measured at nominal supply voltage.

(4) t_{pd} is the same as t_{PHL} and t_{PLH}.

(5) t_{pd} is the same as t_{PHL} only.

(6) t_{en} is the same as t_{PZL} and t_{PZH}.

(7) t_{dis} is the same as t_{PLZ} and t_{PHZ}.

9.6 Operating Characteristics

T_A=25°C

PARAMETER	TEST CONDITIONS	TYP	UNIT
C _{pd} ⁽¹⁾	f _i = 1 MHz; V _I = GND to V _{CC} ⁽²⁾⁽³⁾	115	pF

(1) Power dissipation capacitance per transceiver.

(2) C_{PD} is used to determine the dynamic power dissipation (P_D in μW).

$$P_D = C_{PD} \times V_{CC}^2 \times f_i + \sum (C_L \times V_{CC}^2 \times f_o) \text{ where:}$$

f_i = input frequency in MHz;

f_o = output frequency in MHz;

$\sum (C_L \times V_{CC}^2 \times f_o)$ = sum of outputs;

C_L = output load capacitance in pF;

V_{CC} = supply voltage in V.

(3) All 9 outputs switching.

10 Parameter Measurement Information

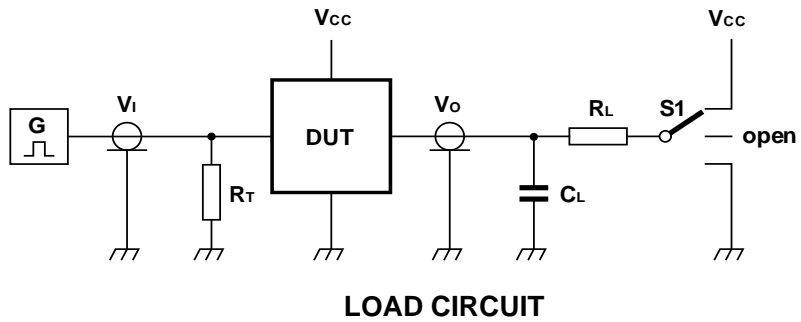

TEST	S1
t_{PHL}/t_{PLH}	Open
t_{PLZ}/t_{PZL}	V_{CC}
t_{PHZ}/t_{PZH}	GND
V_i	V_{CC}
t_r/t_f	6ns
C_L	50pF
R_L	1K Ω

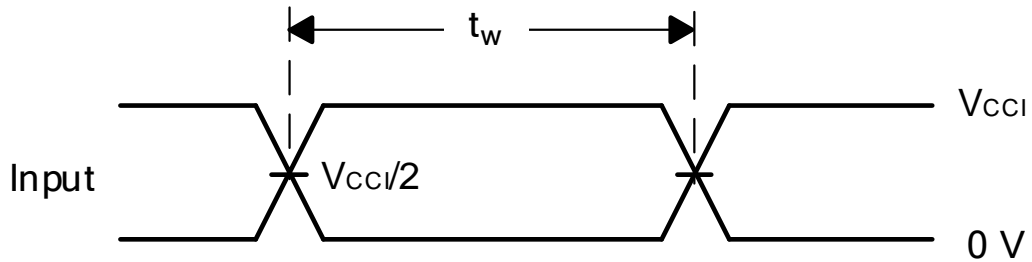

Figure 1. Voltage Waveforms Pulse Duration

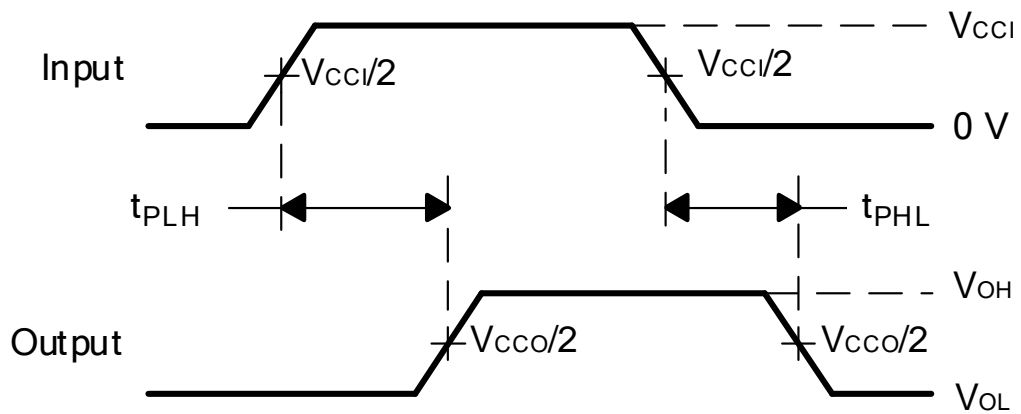

Figure 2. Voltage Waveforms Propagation Delay Times

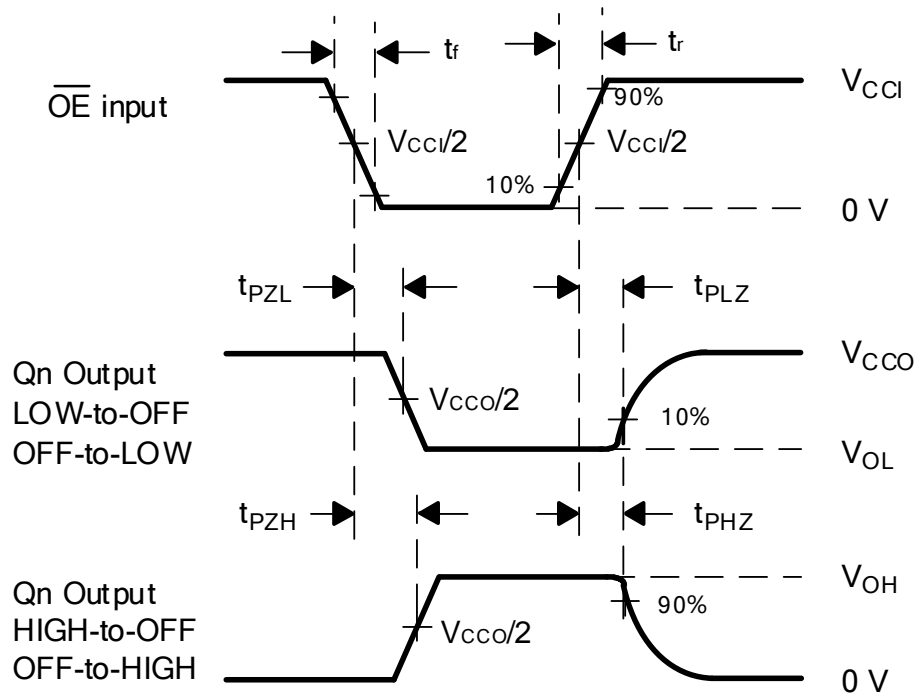

Figure 3. Voltage Waveforms Enable and Disable Times

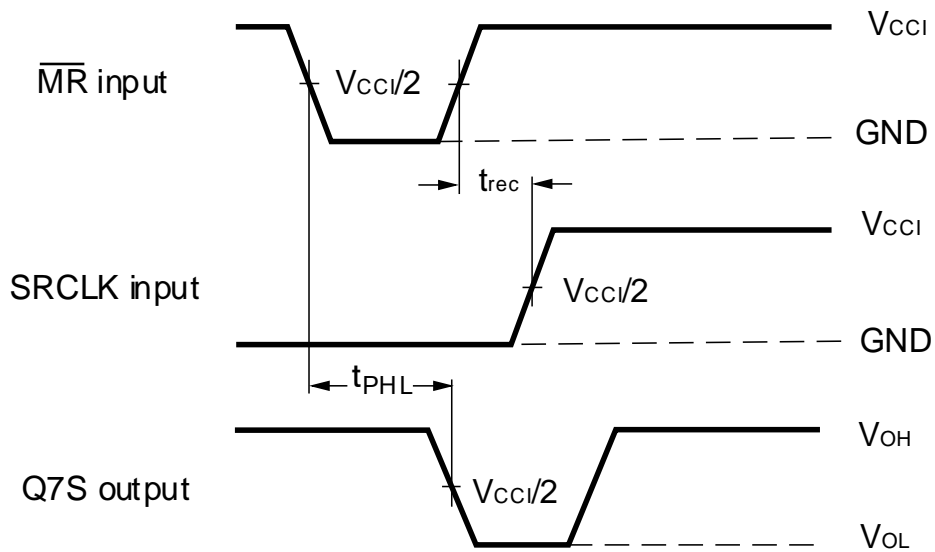

Figure 4. Master Reset to Output Propagation Delays

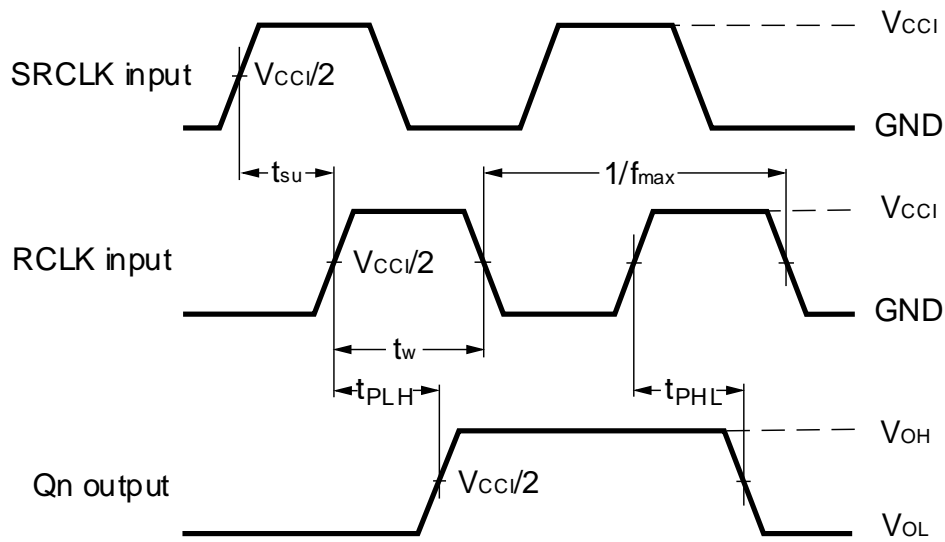

Figure 5. Storage Clock to Output Propagation Delays

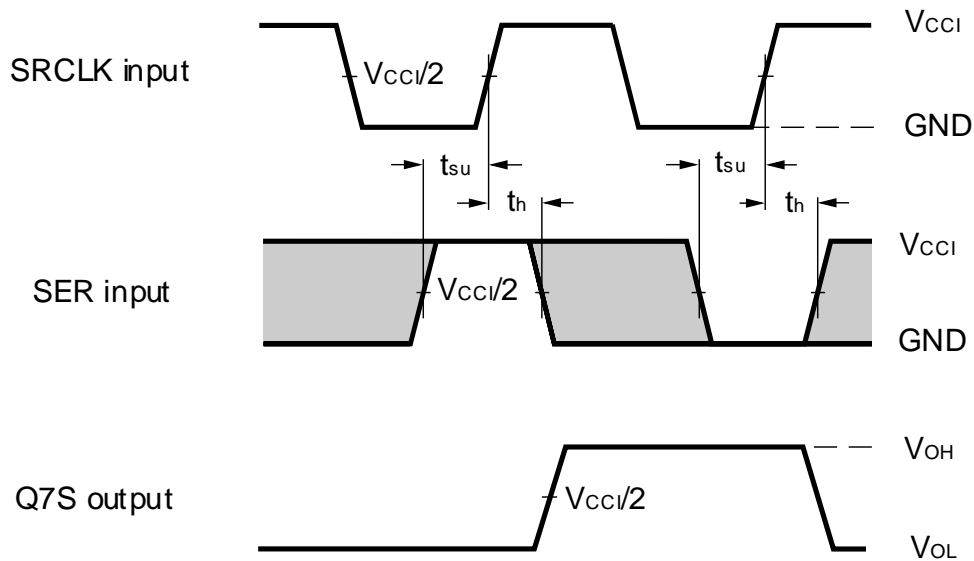
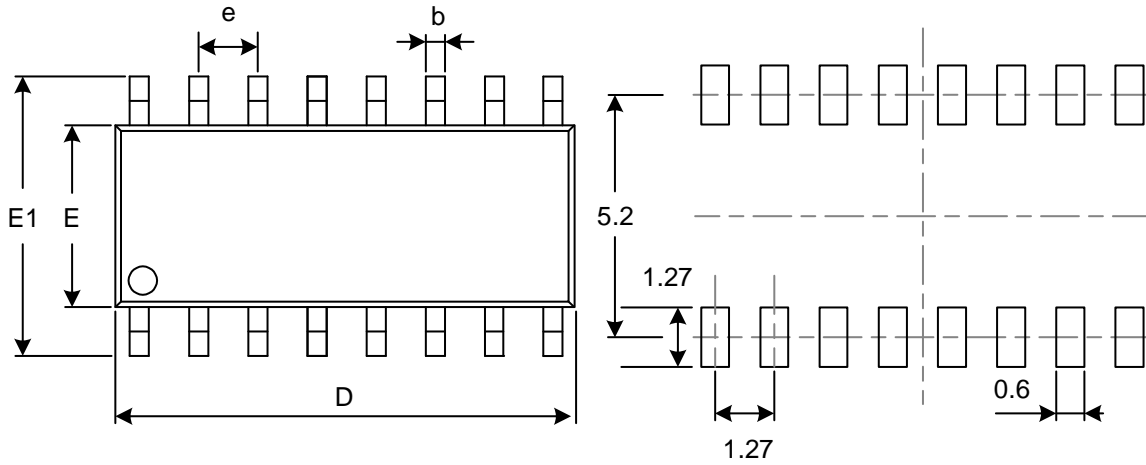

Figure 6. Data Set-up and Hold Times

- NOTES:
- A. CL includes probe and jig capacitance.
 - B. All input pulses are supplied by generators having the following characteristics: PRR≤10 MHz, $Z_0 = 50 \Omega$, $dv/dt \geq 1V/ns$.
 - C. The outputs are measured one at a time, with one transition per measurement.
 - D. t_{PLZ} and t_{PHZ} are the same as t_{dis} .
 - E. t_{PZL} and t_{PZH} are the same as t_{en} .
 - F. t_{PLH} and t_{PHL} are the same as t_{pd} .
 - G. All parameters and waveforms are not applicable to all devices.
 - H. The shaded areas indicate when the input is permitted to change for predictable output performance.
 - I. V_{OL} and V_{OH} are typical output voltage levels that occur with the output load.

11 PACKAGE OUTLINE DIMENSIONS

SOIC-16(SOP16)



RECOMMENDED LAND PATTERN (Unit: mm)

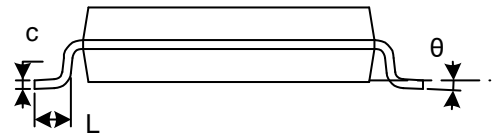
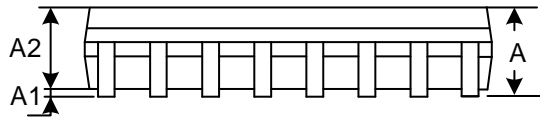

Symbol	Dimensions In Millimeters		Dimensions In Inches	
	Min	Max	Min	Max
A		1.750		0.069
A1	0.100	0.225	0.004	0.009
A2	1.300	1.500	0.051	0.059
b	0.390	0.470	0.015	0.019
c	0.200	0.240	0.007	0.010
D	9.800	10.00	0.386	0.394
E	3.800	4.000	0.150	0.157
E1	5.800	6.200	0.228	0.244
e	1.270 (BSC)		0.050 (BSC)	
L	0.500	0.800	0.020	0.032
θ	0°	8°	0°	8°

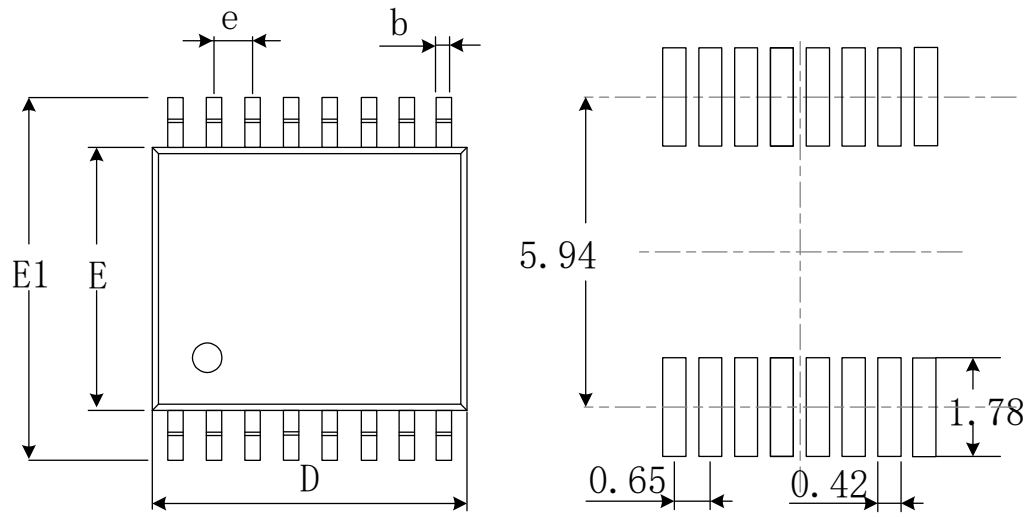
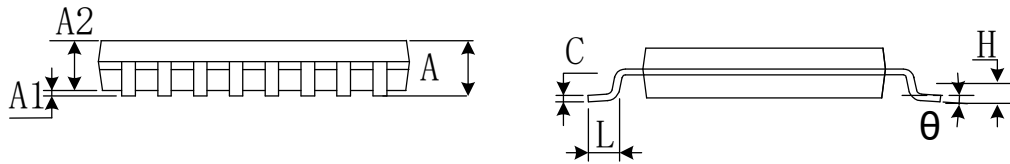
TSSOP-16

RECOMMENDED LAND PATTERN (Unit: mm)

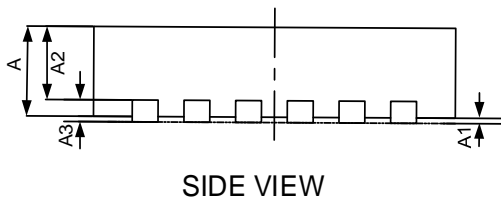
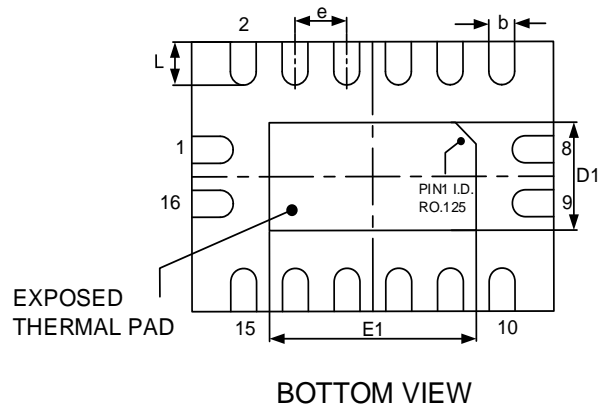
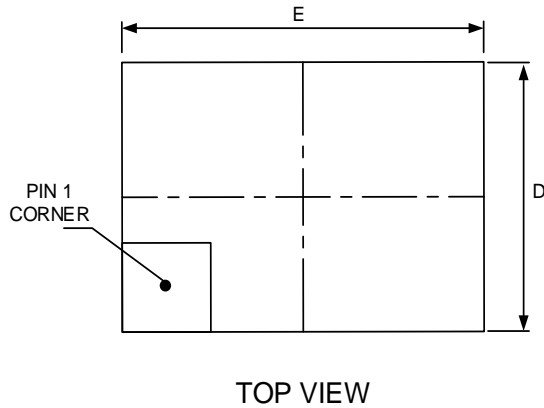
Symbol	Dimensions In Millimeters		Dimensions In Inches	
	Min	Max	Min	Max
A		1.200		0.047
A1	0.050	0.150	0.002	0.006
A2	0.900	1.050	0.035	0.041
b	0.200	0.280	0.007	0.011
c	0.130	0.170	0.005	0.007
D	4.900	5.100	0.193	0.201
E	4.300	4.500	0.169	0.177
E1	6.200	6.600	0.244	0.260
e	0.650(BSC)		0.026(BSC)	
L	0.450	0.750	0.017	0.030
H	0.250 TYP		0.010 TYP	
θ	0°	8°	0°	8°

QFN2.5x3.5-16L

Symbol	Dimensions In Millimeters		Dimensions In Inches	
	Min	Max	Min	Max
A	0.700	0.800	0.027	0.032
A1	0.000	0.050	0.000	0.002
A2	0.600	0.700	0.024	0.028
A3	0.203(REF)		0.008(REF)	
D	2.400	2.600	0.094	0.102
E	3.400	3.600	0.134	0.142
e	0.500(BSC)		0.020(BSC)	
b	0.200	0.300	0.007	0.012
L	0.300	0.500	0.012	0.020
D1	0.850	1.150	0.033	0.045
E1	1.850	2.150	0.073	0.085

NOTE:

- A. All linear dimension is in millimeters.
- B. This drawing is subject to change without notice.
- C. Body dimensions do not include mold flash or protrusion. Mold flash and protrusion shall not exceed 0.15 per side.
- D. BSC: Basic Dimension. Theoretically exact value shown without tolerances.
- E. REF: Reference Dimension, usually without tolerance, for information purposes only.

12 TAPE AND REEL INFORMATION

REEL DIMENSIONS

TAPE DIMENSION

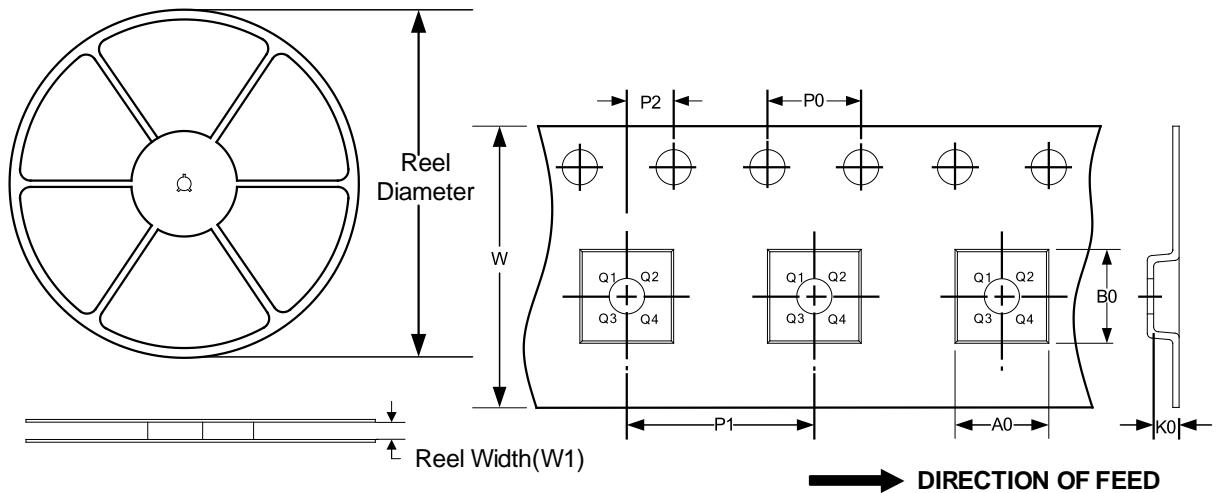

NOTE: The picture is only for reference. Please make the object as the standard.

KEY PARAMETER LIST OF TAPE AND REEL

Package Type	Reel Diameter	Reel Width(mm)	A0 (mm)	B0 (mm)	K0 (mm)	P0 (mm)	P1 (mm)	P2 (mm)	W (mm)	Pin1 Quadrant
SOIC-16(SOP16)	13"	16.4	6.50	10.30	2.10	4.0	8.0	2.0	16.0	Q1
TSSOP16	13"	12.4	6.90	5.60	1.20	4.0	8.0	2.0	12.0	Q1
QFN2.5x3.5-16L	7"	15.0	2.80	3.80	1.20	4.0	4.0	2.0	12.0	Q1

NOTE:

1. All dimensions are nominal.
2. Plastic or metal protrusions of 0.15mm maximum per side are not included.

IMPORTANT NOTICE AND DISCLAIMER

Jiangsu Runic Technology Co., Ltd. will accurately and reliably provide technical and reliability data (including data sheets), design resources (including reference designs), application or other design advice, WEB tools, safety information and other resources, without warranty of any defect, and will not make any express or implied warranty, including but not limited to the warranty of merchantability Implied warranty that it is suitable for a specific purpose or does not infringe the intellectual property rights of any third party.

These resources are intended for skilled developers designing with Runic products You will be solely responsible for: (1) Selecting the appropriate products for your application; (2) Designing, validating and testing your application; (3) Ensuring your application meets applicable standards and any other safety, security or other requirements; (4) Runic and the Runic logo are registered trademarks of Runic Incorporated. All trademarks are the property of their respective owners; (5) For change details, review the revision history included in any revised document. The resources are subject to change without notice. Our company will not be liable for the use of this product and the infringement of patents or third-party intellectual property rights due to its use.