

REV.	ECN NO.	REVISED	DATE

- NOTE:
- MATERIAL:
 - HOUSING: THERMOPLASTIC GLASS FIBRE UI-94V-0
 - CONTACT: PHOSPHOR BRONZE (SURFACE PLATING: A*U*)
 - ELECTRIC:
 - CONTACT RESISTANCE: 30 MILLIOHMS MAX
 - INSULATION RESISTANCE: 1000 MEGA OHMS MIN
 - DIELECTRIC VOLTAGE: 500V AC ONE SEC LEVEL
 - OPERATING TEMPERATURE: -40°C ~ +80°C
- SEE ORDERING INFORMATION

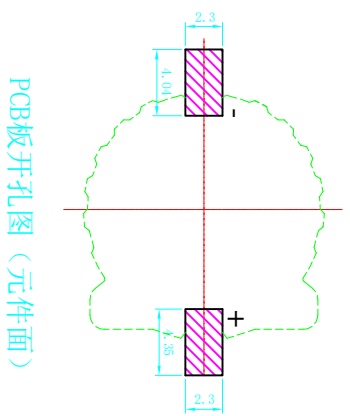
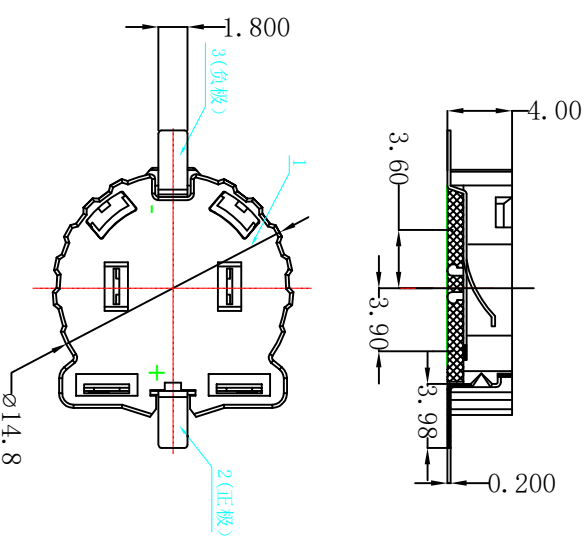
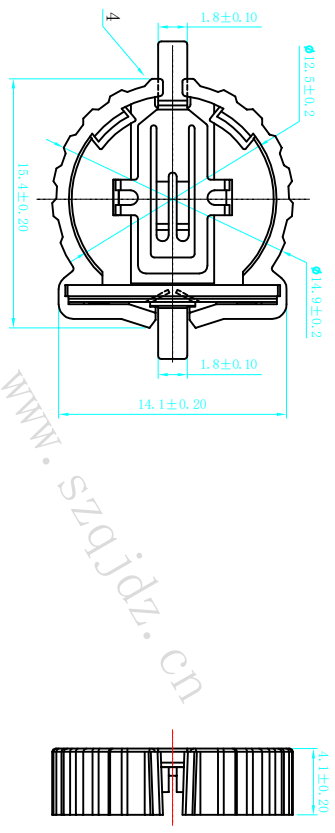

ORDERING INFORMATION

QJ-BS-12-B*005**

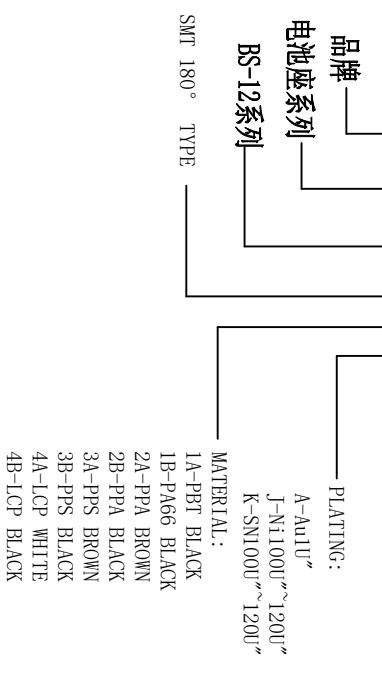

UNLESS OTHERWISE SPECIFIED TOLERANCES		SCALE: 1:1		VIEW: ④		PART NO:	
DECIMALS:	ANGLES:	UNIT: mm	REV: A/0	OBJECT: QJ	QJ-BS-12-B3AA005		
X : ±0.30	X : ±1°	QJ: LIUSU	DATE: 2020.10.17	DATE: 2020.10.17	TITLE: CR1220-2 SMT-WZ		
X X : ±0.25	X X : ±0.20	CHKD: QJ.HUAN	DATE: 2020.10.18	DATE: 2020.10.18			
X.XX : ±0.20	X.XX : ±0.10	APVD: QJ.QILIU	DATE: 2020.10.18	DATE: 2020.10.18			
X.XXX : ±0.10	WEIGHT: 0.6 g	SHEET 1 OF 1					
TERMINAL (-)		PHOSPHOR BRONZE, T=0.20MM		Gold Plating and Ni Under-Plating			
TERMINAL (+)		PHOSPHOR BRONZE, T=0.20MM		Gold Plating and Ni Under-Plating			
HOUSING		PPS		BROWN			
PART NAME		QJ TY		MATERIAL		PLATING & COLOR	

深圳市琦捷电子有限公司 www.szqjdz.cn 0755-23112665