

A  
B  
C  
D  
E  
F  
G  
H  
I  
J

A  
B  
C  
D  
E  
F  
G  
H  
I  
J

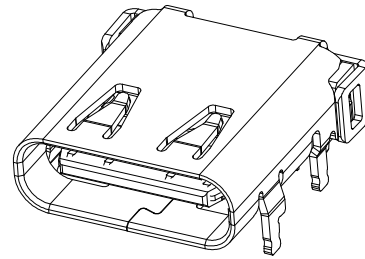

- NOTE:
- MATERIAL SPECIFICATION:
    - HOUSING:HIGH TEMPERATURE RESISTANT PLASTIC,UL94 V-0.(PA9T)
    - CONTACTS:COPPER ALLOY(C1815)
    - MID PLATE: STAINLESS STEEL(SUS301)
    - FRONT SHELL: STAINLESS STEEL(SUS304)
    - EMI PLATE: STAINLESS STEEL(SUS304)
  - PLATING SPECIFICATION:
    - CONTACTS:
      - Ni 50u" MIN. UNDER PLATED OVER ALL.
      - Au PLATED ON THE FUNCTIONAL AREA OF CONTACT.
      - CONTACT FUNCTIONAL AREA PLATED : Au G/F
      - CONTACT SOLDER AREA PLATED : Au G/F
    - FRONT SHELL:
      - Ni 30u" MIN. UNDER PLATED OVER ALL.
    - MID PLATE&EMI PLATE:
      - CLEAR ONLY
  - MECHANICAL PERFORMANCE,
    - INSERTION FORCE: 0.5~2.0kgf.
    - REMOVAL FORCE: 0.8kgf~2.0kgf.
    - DURABILITY: 10000 CYCLES.
  - ELECTRICAL PERFORMANCE,
    - CURRENT RATING:5.0A  
VOLTAGE RATING:5.0V
    - LLCR:
      - VBUS & GND PINS AND OTHER PINS: 40mA/PIN MAX.
      - LLCR MAX. CHANGE OF ALL PINS: 10mA.
    - INSULATION RESISTANCE: 100MΩ MIN
    - DIELECTRIC WITHSTAND VOLTAGE,AC 100V FOR 1 MINUTE.
  - ENVIRONMENTAL PERFORMANCE:
    - OPERATING TEMPERATURE: -40°C~+85°C.
  - IR REFLOW:
    - THE PEAK TEMPERATURE ON THE BOARD SHALL BE MAINTAINED FOR 10 SECONDS AT 260°C.

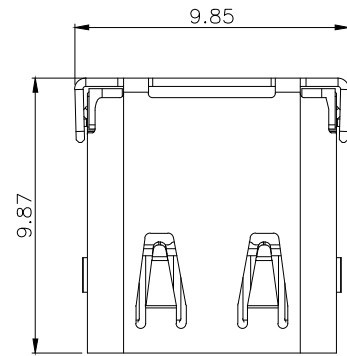
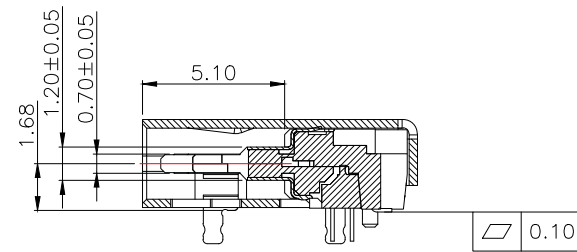
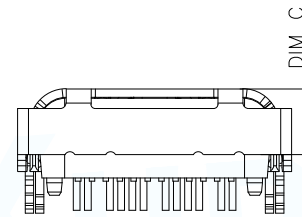
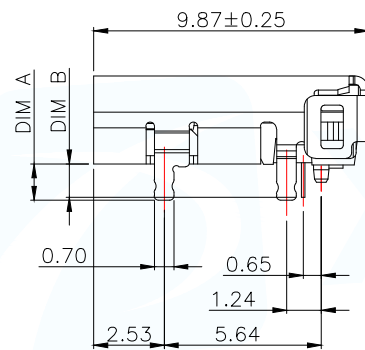
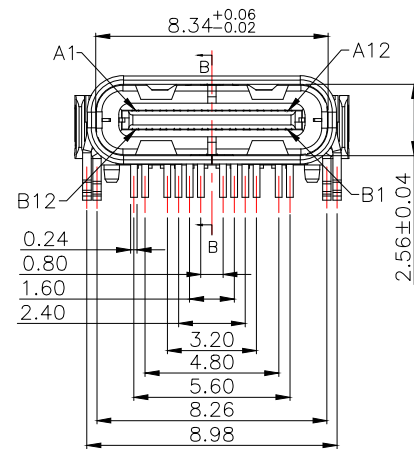

SECTION B-B  
SCALE 1:1

0.10

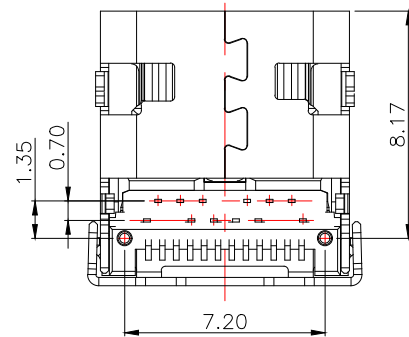

MANUFACTURE DWG		东莞市讯普电子科技有限公司 DongGuan XunPu Electronics Co.,Ltd	
UNLESS OTHERWISE SPECIFIED TOLERANCES			TITLE: USB C F 24PIN DIP+SMT WITH SPRING&POST
DECIMALS:	ANGLES:		PAR TYPEC-324DBW-ECP24A
.X:±0.30	X':±10'		DWN
.XX:±0.20	.X':±8'		CHKD
.XXX:±0.10	.XX':±5'	CUSTOMER COPY	APVD SCALE:1:1 UNIT:MM SIZE:A4 SHEET:1F1 REV:A

TABLE 1

ITEM	P/N	DIM"A"	DIM"B"	DIM"C"	HOUSING CLOER	PLATING	
						MATING AREA	SOLDER AREA
1	TYPEC-324DBW-ECP24A	1.30	1.20	1.96	BALCK	Au:1u"	Au:G/F

USB TYPE-C PIN ASSIGNMENTS

PIN NUMBER	SIGNAL NAME	PIN NUMBER	SIGNAL NAME
A1	GND	B12	GND
A2	TXp1+	B11	RXp1+
A3	TXn1-	B10	RXn1-
A4	Vbus	B9	Vbus
A5	CC1	B8	SBU2
A6	Dp1	B7	Dn2
A7	Dn1	B6	Dp2
A8	SBU1	B5	CC2
A9	Vbus	B4	Vbus
A10	RXn2-	B3	TXn2-
A11	RXp2+	B2	TXp2+
A12	GND	B1	GND

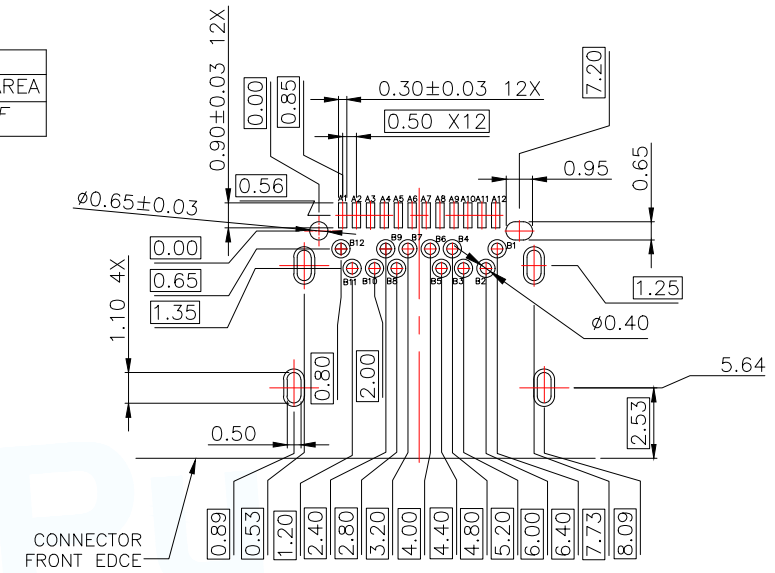

RECOMMENDED P.C.B. LAYOUT (T=1.00mm)  
TOLERANCE UNSPECIFIED ±0.05mm

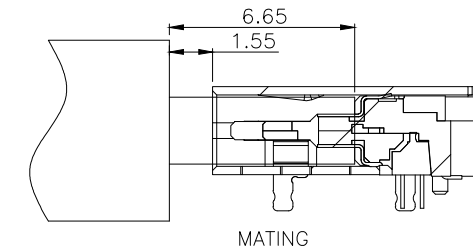

MANUFACTURE DWG		 东莞市讯普电子科技有限公司 DongGuan XunPu Electronics Co.,Ltd	
UNLESS OTHERWISE SPECIFIED TOLERANCES		TITLE: USB C F 24PIN DIP+SMT WITH SPRING&POST PAR TYPEC-324DBW-ECP24A DWN CHKD APVD SCALE:1:1 UNIT:MM SIZE:A4 SHEET:1F1	
DECIMALS:	ANGLES:		
.X:±0.30	X':±10'		REV:A
.XX:±0.20	.X':±8'		
.XXX:±0.10	.XX':±5'		
CUSTOMER COPY			

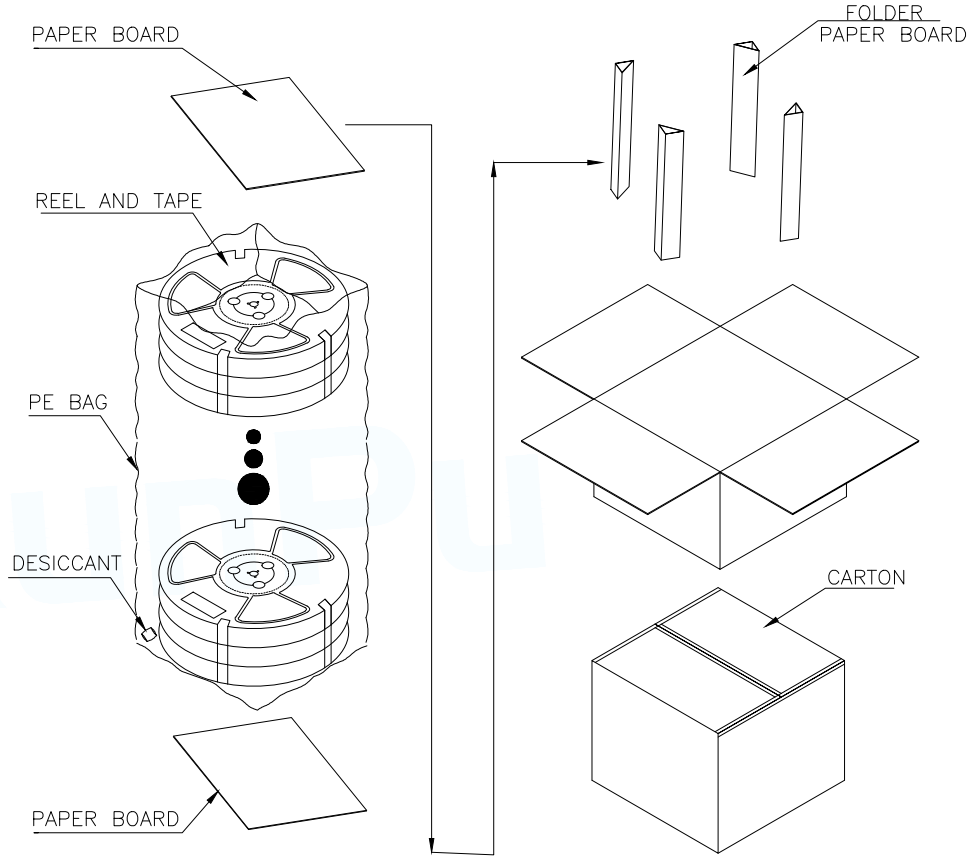
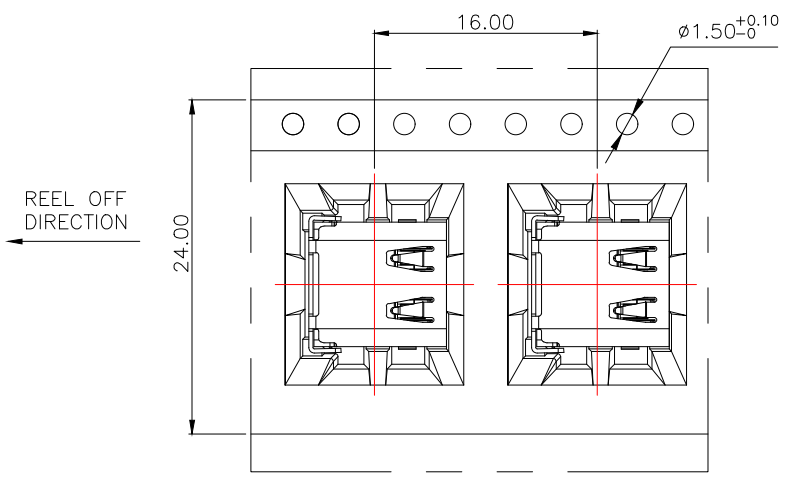
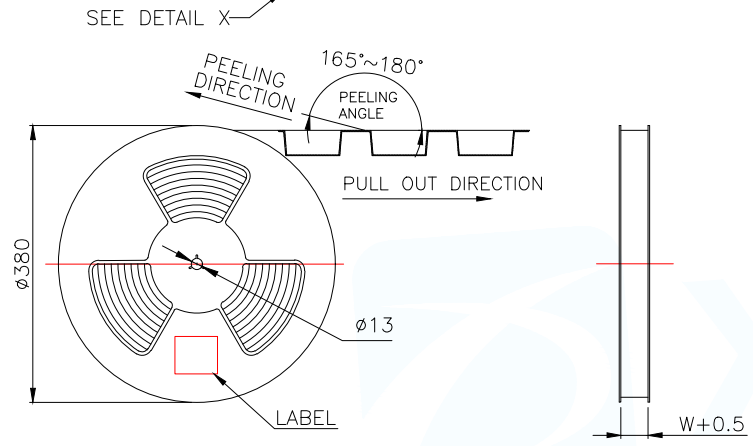
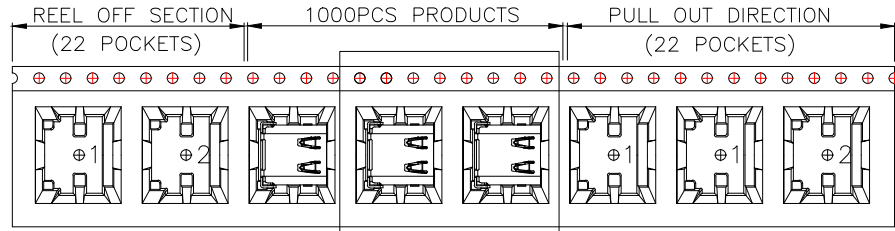

	REEL/TRAY	CARTON
CONNECTOR (PCS)	1000	10000

MANUFACTURE DWG		东莞市讯普电子科技有限公司 DongGuan XunPu Electronics Co.,Ltd	
UNLESS OTHERWISE SPECIFIED TOLERANCES		TITLE: USB C F 24PIN DIP+SMT WITH SPRING&POST PAR TYPEC-324DBW-ECP24A	
DECIMALS:	ANGLES:	DWN	
.X:±0.30	X':±10°	CHKD	
.XX:±0.20	.X':±8°	APVD	
.XXX:±0.10	.XX':±5°	SCALE 1:1	UNIT:MM
CUSTOMER COPY		SIZE:A4	SHEET:1F1
			REV:A