

NOTE:

- MATERIAL SPECIFICATION:
  - HOUSING:HIGH TEMPERATURE RESISTANT PLASTIC,UL94 V-0.
  - CONTACTS: COPPER ALLOY
  - MID PLATE: STAINLESS STEEL
  - FRONT SHELL: STAINLESS STEEL
  - EMI PLATE: STAINLESS STEEL
- PLATING SPECIFICATION:
  - CONTACTS:
    - Ni 50u" MIN. UNDER PLATED OVER ALL.
    - Au PLATED ON THE FUNCTIONAL AREA OF CONTACT.
    - CONTACT FUNCTIONAL AREA PLATED : Au G/F
    - CONTACT SOLDER AREA PLATED : Au G/F
  - FRONT SHELL:
    - Ni 30u" MIN. UNDER PLATED OVER ALL.
  - MID PLATE:
    - Ni 30u" MIN. UNDER PLATED OVER ALL.
    - Sn 80u"MIN. PLATED OVER ALL
  - EMI PLATE:
    - CLEAR ONLY
- MECHANICAL PERFORMANCE,
  - INSERTION FORCE: 0.5~2.0kgf.
  - REMOVAL FORCE: 0.8kgf~2.0kgf.
  - DURABILITY: 10000 CYCLES.
- ELECTRICAL PERFORMANCE,
  - CURRENT RATING:5.0A  
VOLTAGE RATING:5.0V
  - LLCR:
    - VBUS & GND PINS AND OTHER PINS: 40mA/PIN MAX.
    - LLCR MAX. CHANGE OF ALL PINS: 10mA.
  - INSULATION RESISTANCE: 100MΩ MIN
  - DIELECTRIC WITHSTAND VOLTAGE,AC 100V FOR 1 MINUTE.
- ENVIRONMENTAL PERFORMANCE:
  - OPERATING TEMPERATURE: -40°C~+85°C.
- IR REFLOW:
  - THE PEAK TEMPERATURE ON THE BOARD SHALL BE MAINTAINED FOR 10 SECONDS AT 260°C.

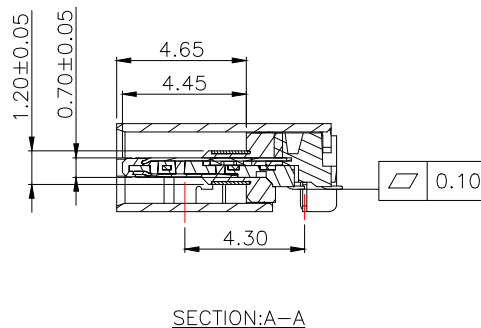

MANUFACTURE DWG		东莞市讯普电子科技有限公司 DongGuan XunPu Electronics Co.,Ltd	
UNLESS OTHERWISE SPECIFIED TOLERANCES			TITLE: USB CF 24PIN SMT TYPE MID-MOUNT 0.8
			PAR TYPEC-325-ECP24SC08
DECIMALS:	ANGLES:		DWN
.X:±0.30	X':±10'		CHKD
.XX:±0.20	.X':±8"	APVD	
.XXX:±0.10	.XX':±5"	SCALE 1:1	UNIT:MM
		CUSTOMER COPY	SIZE:A4
			SHEET:1F1
			REV:A

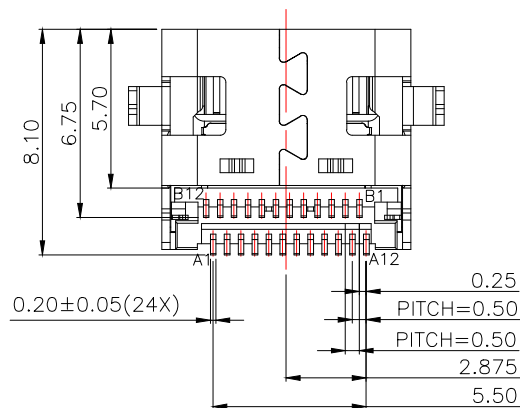
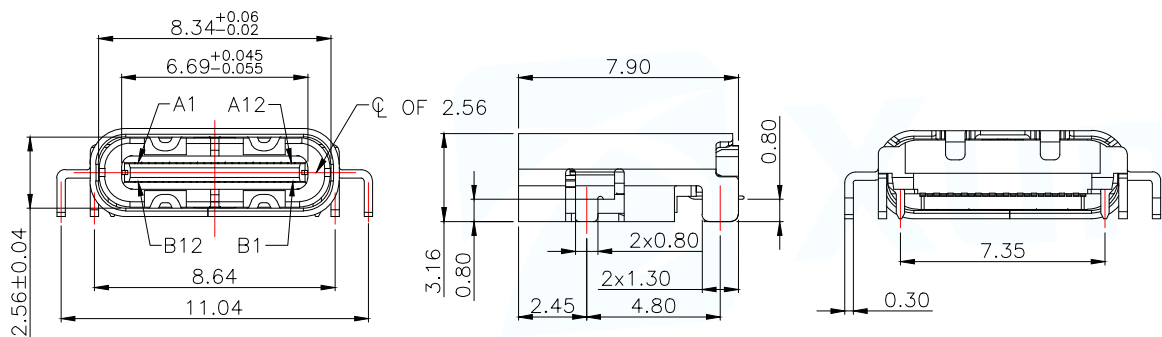
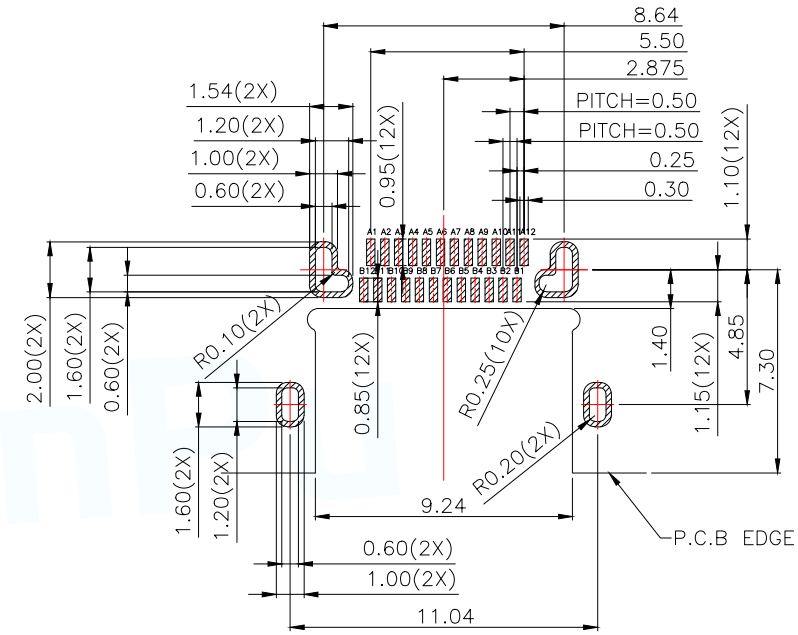
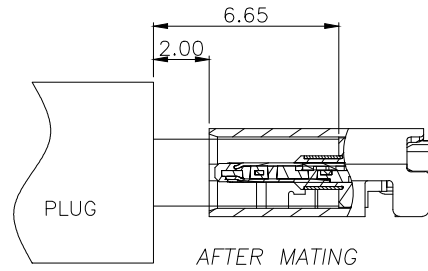

RECOMMENDED PCB LAYOUT(TOP VIEW)  
THICKNESS 0.60MM;DEFAULT TOLERANCE:±0.05

USB TYPE-C PIN ASSIGNMENTS

PIN NUMBER	SIGNAL NAME	PIN NUMBER	SIGNAL NAME
A1	GND	B12	GND
A2	SSTXp1	B11	SSRXp1
A3	SSTXn1	B10	SSRXn1
A4	VBUS	B9	VBUS
A5	CC1	B8	SBU2
A6	Dp1	B7	Dn2
A7	Dn1	B6	Dp2
A8	SBU1	B5	CC2
A9	VBUS	B4	VBUS
A10	SSRXn2	B3	SSTXn2
A11	SSRXp2	B2	SSTXp2
A12	GND	B1	GND

MANUFACTURE DWG			东莞市讯普电子科技有限公司 DongGuan XunPu Electronics Co.,Ltd	
UNLESS OTHERWISE SPECIFIED TOLERANCES			TITLE: USB CF 24PIN SMT TYPE MID-MOUNT 0.8	
DECIMALS:	ANGLES:	PAR	TYPEC-325-ECP24SC08	
.X:±0.30	X.:±10°	DWN		
.XX:±0.20	.X':±8°	CHKD		
.XXX:±0.10	.XX':±5°	APVD		
CUSTOMER COPY		SCALE 1:1	UNIT:MM	
		SIZE:A4	SHEET:1F1	REV:A

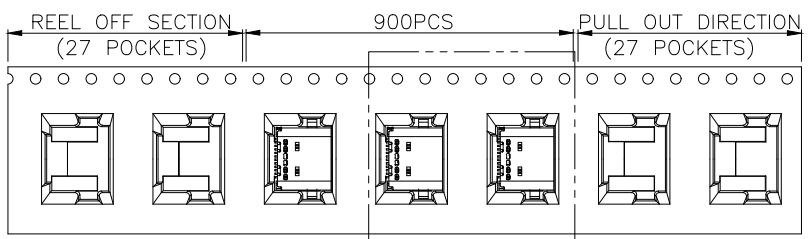

SEE DETAIL X

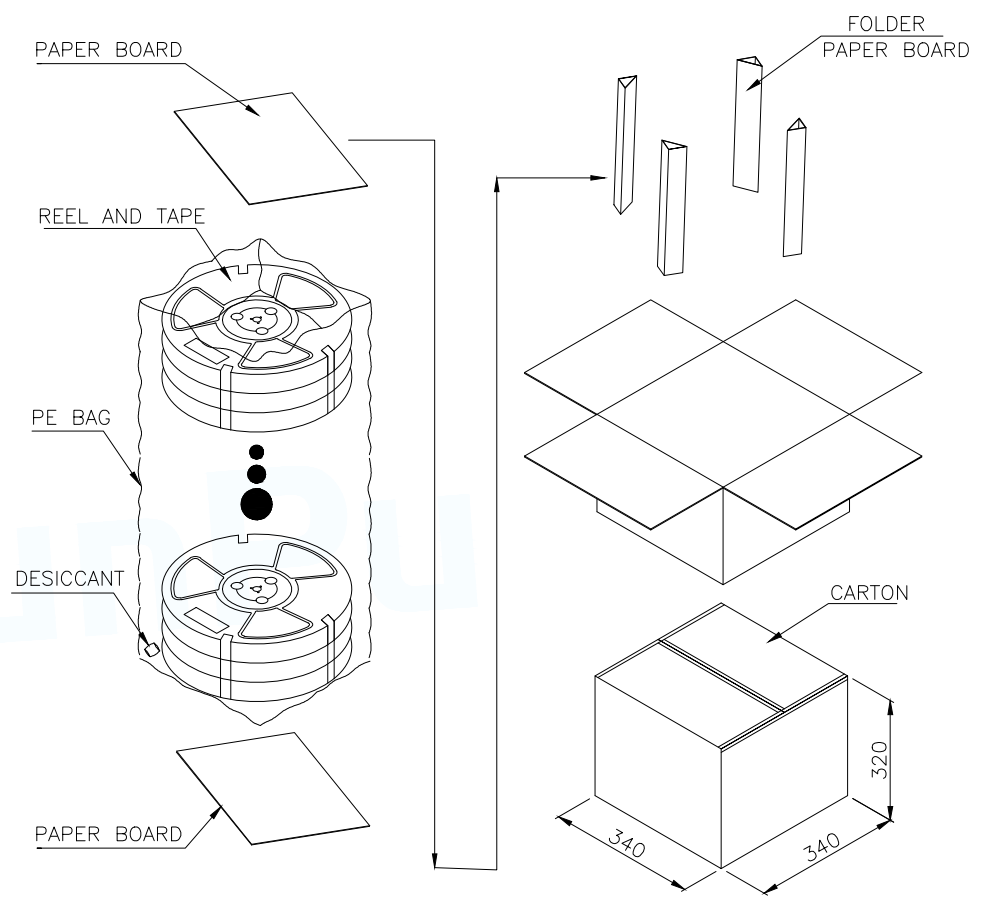
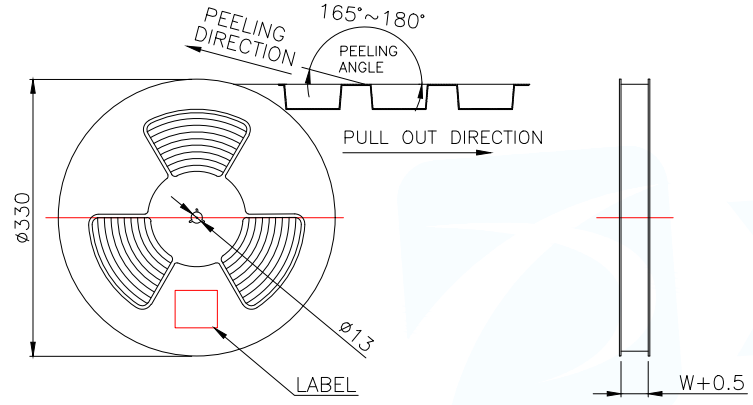

	REEL	CARTON
CONNECTOR (PCS)	900	9000

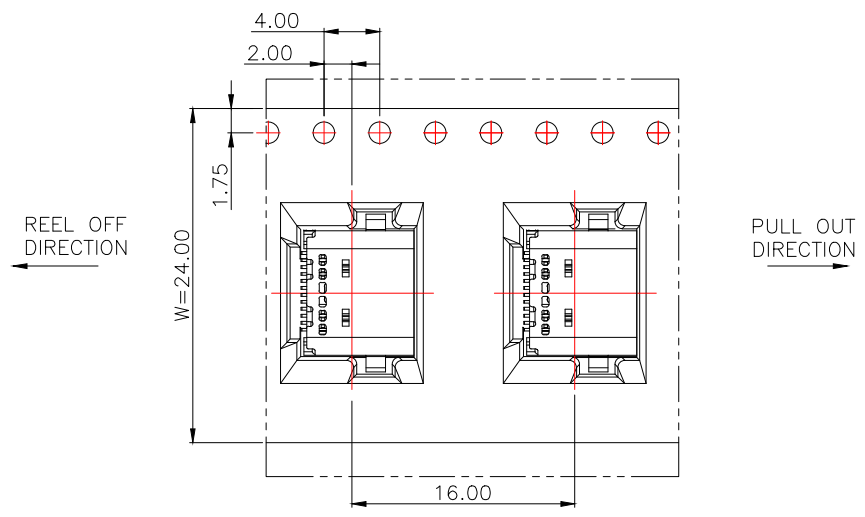

MANUFACTURE DWG		东莞市讯普电子科技有限公司 DongGuan XunPu Electronics Co.,Ltd	
UNLESS OTHERWISE SPECIFIED TOLERANCES		TITLE: USB CF 24PIN SMT TYPE MID-MOUNT 0.8 PAR TYPEC-325-ECP24SC08	
DECIMALS:	ANGLES:	DWN	
.X:±0.30	X':±10°	CHKD	
.XX:±0.20	.X':±8°	APVD	
.XXX:±0.10	.XX':±5°	SCALE:1:1	UNIT:MM
		SIZE:A4	SHEET:1F1
		CUSTOMER COPY	REV:A