

RoHS

MAPX	MODIFICATION	DRW	DATE

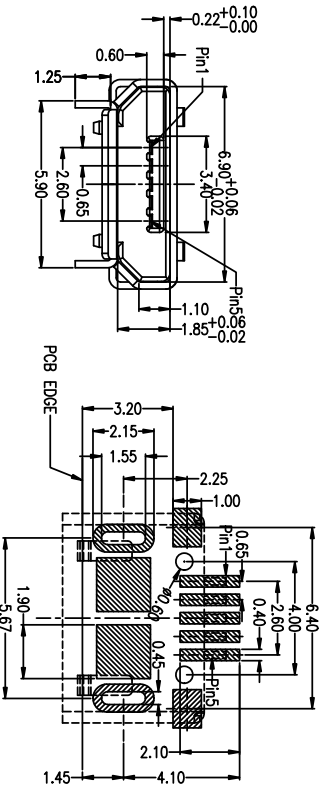
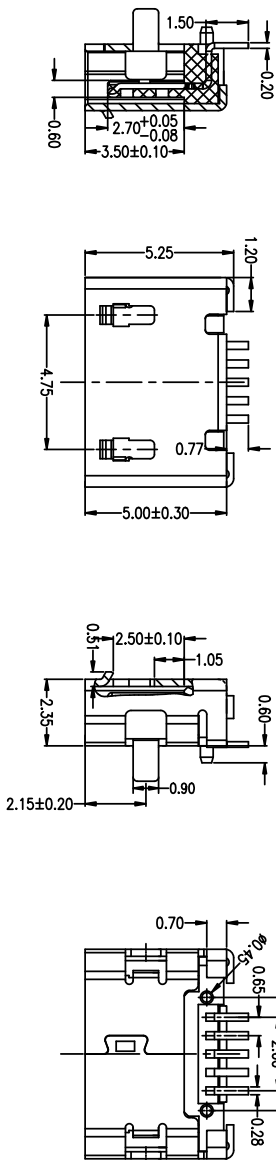
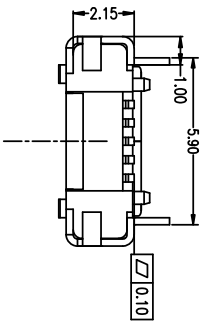

RECOMMENDED PCB LAYOUT PCB图仅供参考

- Note:
- Material:
 - Housing: High temperature thermoplastic with g.f.i.U94V-0
 - Contact: copper alloy,t=0.20mm
 - Shell: copper alloy,t=0.25mm
 - Specification:
 - Current rating:1.5PIN 1.8A Max/2.34PIN 1A Max. voltage: 100 V(ac) for 1 min.
 - Contact resistance: 30 mΩ Max.
 - Insulation resistance: 100 MΩ Min.
 - Total mating force: 3.57 Kgf Max.
 - Total unmating force: 1.0 Kgf Min.
 - Temperature range: -30C~80C

5	GND
4	ID
3	D+
2	D-
1	VBUS
PIN	NAME
PIN ASSIGNMENT	

产品图
深圳市精拓金电子有限公司
 Shenzhen Jing Tuo Jin Electronics Co., Ltd.

公差一览表
 PRODUCT CHART DWG
 TOLERANCE UNLESS OTHERWISE

X.	±0.30	X.	±5°
X.	±0.25	X.	±2°
.XX	±0.20	.XX	±1°
.XXX	±0.10	.XXX	±0.5°

单位	MM	制图	林属升	制料号	920-662A2021S10102
UNITS	MM	DRAWING	林属升	PRODUCT PART NO.	920-662A2021S10102
比例	1:1	审核	郭志富	产品名称	USB 2.0 母座
SCALE	1:1	CHKD	郭志富	PRODUCT NO.	920-662A2021S10102
日期	2016-09-09	批准	黄国荣	角法	第三角法
DATE	2016-09-09	APPD	黄国荣	VIEW	第三角法
				版本	A0
				VER	A0