

客户名称：

ROHS

地 址：

产品名称： 直插独石电容器

产品型号： CT40805B103K500B1 散装 CT4 0805 X7R 103±10% 500V P=5.08mm

料 号： 178MU0008

日 期： 2023-4-18

客户物料编号：

REV：4.0

承制方确认：

拟制	审核	批准
薛子文	王波	王习华

使用方确认：

开发/工程 审核	SQE 审核	批准

● 径向引线多层陶瓷电容器

RADIAL LEADED MLCC

产品型号说明 HOW TO ORDER

示例:CT4      0805      B      681      K      101      B1      T

▼            ▼            ▼            ▼            ▼            ▼            ▼

A            B            C            D            E            F            G            H

A

产品类别 Product Type	
代号 Code	类别 Type
CC4	I 类径向引线电容器 Class I Dielectric Radial Leaded & Micc
CT4	II 类径向引线电容器 Class II Dielectric Radial Leaded & Micc

B

本体尺寸规格(长×宽) Nominal Body Size(L×W)	
0805	0.17×0.15
1206	0.20×0.18
1210	0.20×0.22
1812	0.34×0.26

C:

温度特性 Product Type			
N	NPO	0±30PPm/°C	-55°C ~ +125°C
B	X7R X5R	± 10%	-55°C ~ +125°C
Y	Y5V	+ 80% ~ -20%	-25°C ~ +85°C

D:

标称容量 Nominal Capacitance
前两位数字为有效数字，后一位数字表示零的个数。 First two digits are significant, and the third digit is number of zeros. 例如: For example: 104=100000PF      5R6=5.6PF

E:

容量偏差 Tolerance		
J	± 5.0%	NPO
K	± 10%	X7R X5R
M	± 20%	X7R X5R
Z	+80% ~ -20%	Y5V

F:

额定电压 Rated Voltage
前两位数字为有效数字，后一位数字表示零的个数。 First two digits are significant, and the third digit is number of zeros. 例如: For example: 500=50V      101=100V

G:

引线形式 Leads Type
A1    B1    C1    B2    C2

H:

包装代码 Packaging code	
T 表示全盘式纸袋包装 T=reeled	无代码表示散包装 no code is bulk package

● 尺寸、工作电压、容量工作关系表

SIZ CODE , CAPACITANCE AND VOLTAGE

尺寸 Size	外形 Shape	外形尺寸 (单位 mm) Dimensions (Unit: mm)					工作 电压 Rated voltage	标称容量范围 Available Capacitance Range		
		F ±0.5	H ±1	长 MAX	宽 MAX	厚 MAX		N NPO	B X7R	Y Y5V
0603 0805	A1	5.0	10.0	4.4	4.0	3.0	50V	0R5-222	221-105	103-684
	B1	5.0	10.0	5.8	4.8	3.6	100V	0R5-102	221-683	
	C1	2.5	10.0	4.2	3.8	3.5				
1206	B2	5.0	10.0	5.6	4.3	3.8	50V	0R5-472	102-105	103-105
	C2	2.5	10.0				100V	0R5-392	102-683	
1210	B2	5.0	10.0	7.2	5.5	4.2	50V	561-682	102-205	104-155
							100V	561-472	102-104	
1812	B2	5.0	10.0	8.5	8.5	4.5	50V	102-103	103-334	154-335
	100V						102-682	103-224		

\*其它规格可直接和我们联系

Other are available, contact HY

G图示

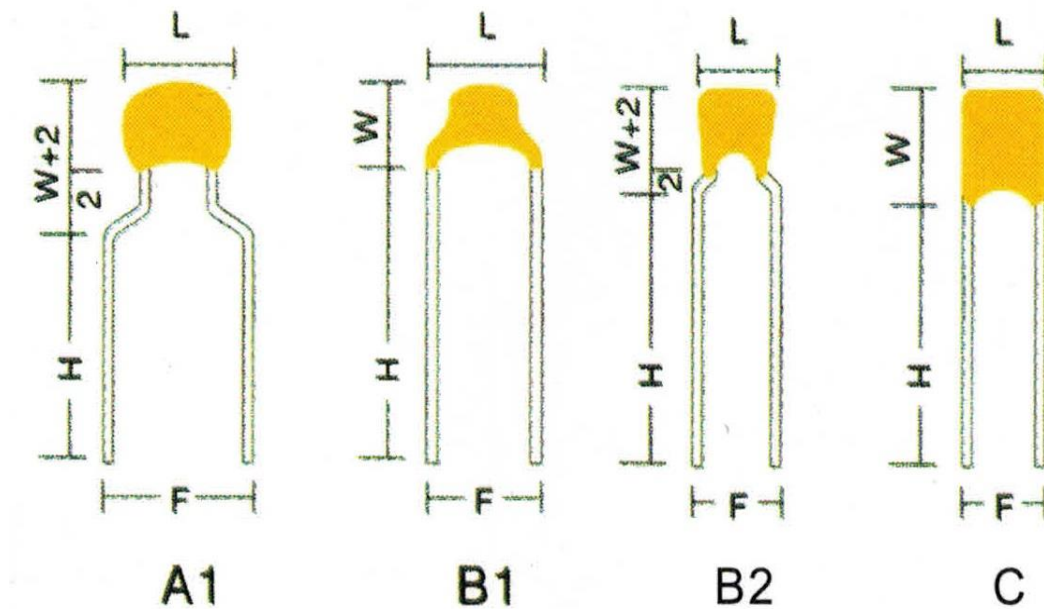

### 包装形式 PACKING STYLE

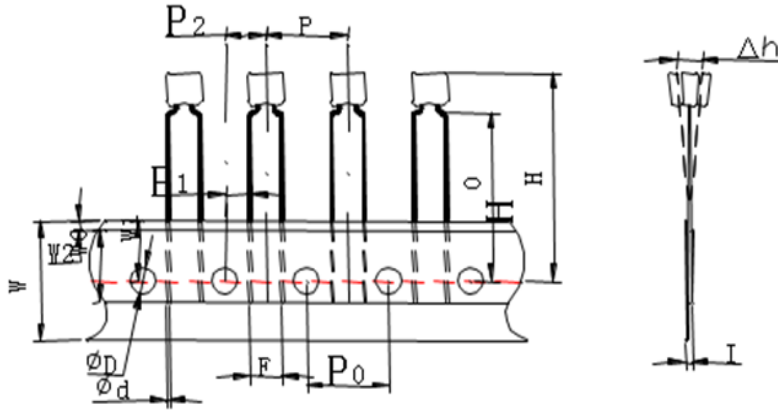

Note:  $P_1 = 3.85\text{mm}$  for  $F = 5.08\text{mm}$ ;  $P_1 = 5.1\text{mm}$  for  $F = 2.54\text{mm}$

代号 Code	P	P <sub>0</sub>	P <sub>1</sub>	P <sub>2</sub>	$\phi d$	$\Delta h$	W	W <sub>0</sub>	W <sub>1</sub>	W <sub>2</sub>	H	H <sub>0</sub>	I	$\phi D$
尺寸 Dim	12.7	12.7	$\frac{3.85}{5.1}$	6.35	0.5	3.3	18.5	8	9	0.8	27	15-20	1.42	4.0
误差 TOL	$\pm 1.0$	$\pm 0.2$	$\pm 0.7$	$\pm 1.3$	$\pm 0.1$	$\pm 1.0$	$\pm 1.0$	$\pm 1.0$	$\pm 0.5$	$\pm 1.5$	Max	$\pm 0.5$	Max	$\pm 0.2$

### 盒带包装 AMMO PACKING

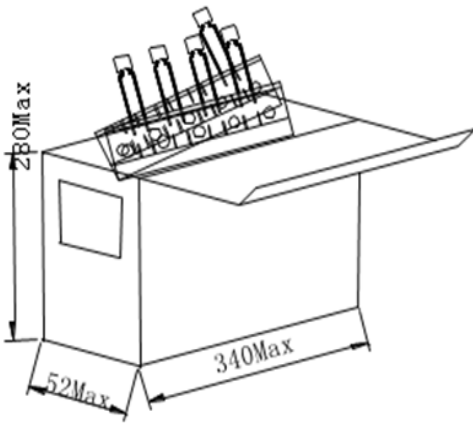

### 卷带包装 TAPE & REEL PACKING

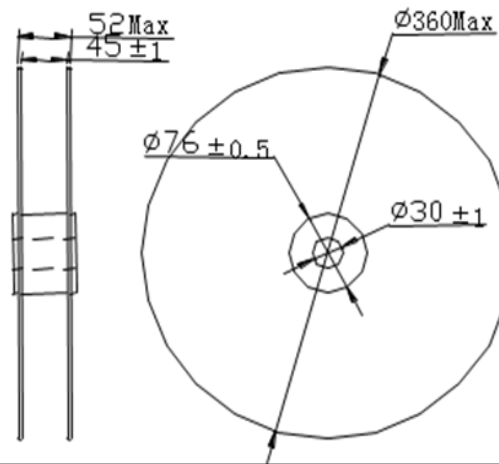

- 引线陶瓷电容器（径向,轴向）LEADS CERMIC CAPACITOR(RADIA.AXIAL)
- 特性 Feature

\*体积小, 容量大, 适合自动安装的卷 (编) 包装.

Miniature size, large capacitance, tape and reel packaging suitable for auto-placement

\*环氧树脂封装, 从而具有优良的防潮性能、机械强度及耐热性。

Epoxy resin coating creates excellent performance in humidity resistance, mechanical strength and heat resistance

\*工业生产标准尺寸及多种脚型产品

Standard size, various lead configuration

● 通用型引线 MLCC 可靠性及测试方法

项目 Item	技术要求 Technical Specification		测试方法和备注 Test Method and Remarks		
容量 Capacitance(C)	I 类 Class I	应符合指定的误差级别 Within the specified tolerance.	标称容量 Capacitance	测试频率 Measuring Frequency	测试电压 Measuring Voltage
			≤1000pf	1MHZ±10%	1.0V
			>1000pf	1KHZ±10%	
	II 类 Class II	应符合指定的误差级别 Within the specified tolerance.	对于 II 类电容器, 测试前应先预处理 The capacitor should be pretreated before measured.		
			测试频率 Measuring Frequency	测试电压 Measuring Voltage	
			1KHZ±10%	B	Y
				1.0V	0.3V
损耗角正切 Dissipation Factor (DF)	I 类 Class I	CR ≥ 50PF DF ≤ 0.15% CR ≥ 50PF DF ≤ 0.15% [(150/CR)+7] × 10 <sup>-4</sup>	标称容量 Capacitance	测试频率 Measuring Frequency	测试电压 Measuring Voltage
			≤1000pf	1MHZ±10%	1.0V
			>1000pf	1KHZ±10%	
	II 类 Class II	B	DF ≤ 3.5%	测试频率: 1KHZ ± 10%      测试电压: 1.0V Measuring Frequency      Measuring Voltage	
	Y	≤7.5% (CR ≤ 0.1uF) (1uF > CR ≥ 0.1uF) ≤15% (CR ≥ 1uF)	测试频率: 1KHZ ± 10% Measuring Frequency: 1KHZ ± 10% 测试电压: 0.5V Measuring Voltage : 0.5V		
绝缘电阻 Insulation Resistance	I 类 Class I	C ≤ 10nF IR ≥ 10000M Ω C > 10nF R.C ≥ 100M Ω .uF	测试电压: 额定电压 Measuring Voltage : Rated Voltage 测试时间: 60 ± 5 秒 Duration: 60 ± 5s		
	II 类 Class II	C ≤ 25nF IR ≥ 4000M Ω C > 25nF R.C ≥ 100M Ω .uF			
项目 Item	技术要求 Technical Specification		测试方法和备注 Test Method and Remarks		

耐电压 Withstanding Voltage	不应有介质被击穿或损伤 No breakdown or damage		端子间: 持续时间: 5±1 秒 Between terminals: Duration: 5±1s 测试电压: Measuring Voltage: I 类: 300% 额定电压 Class I: 300% Rated voltage II 类: 250% 额定电压 Class II: 250% Rated voltage 充/放电电流不应超过 50mA The charge/discharge current is less than 50mA
			端子与外装间: Between terminals and body: 施加电压: 2.5UR 持续时间: 1~5S Voltage: 2.5UR Duration: 1~5S 金属小球法 Small metallic ball method 将电容器本体插入盛满直径为 1mm 的金属小球的容器中, 但保留距端头处 2mm 的本体不插入, 试验电压施加在短路回路端子和金属小球之间. Small metallic balls with 1mm diameters shall be Put in a vessel and the be submerged except 2mm From the top of its component body and the terminals. The test voltage shall be applied between the short-circuited terminals and the metallic balls.
可焊性 Solder ability	上锡率应大于 95% Lead wire shall be at least 95 covered with a new solder coating		将电容器引线浸入含有 25% 松香的酒精溶液中, 然后浸入温度: 230±5℃ 的金属焊锡中 2±0.5 秒. 注意: 电容器本体底面距离锡面约 1.5~2mm, The lead wire of capacitor is dipping into 25% rosin Solution of ethanol and then into molten solder of 230±5℃ For 2±5s. In both cases the depth of dipping is up to about 1.5~2mm from the terminal body.
耐焊接热 Resistance to Soldering Heat	项目 Item Class I	C/C ≤ ±2.5% or ±0.25Pf 取较大值 Whichever is larger	锡温: 260±5℃ 时间: 10 ±1s Solder temperature: 260±5℃ 浸入条件: 将电容器插入厚度为 1.6mm. 孔径为 1.0 mm PC 板. Immersed conditions: Inserted into the PC board 对于 I 类价质, 试验后, 应在标准条件下恢复 4-24 小时后才测试. For class I, 4 to 24 hours of recovery under the standard Condition after test. 对于 II 类价质, 试验后, 应在试验前应先进行如下预处理: 150+0/-10℃, 1 小时, 接着在标准条件下恢复 48±4 小时. Reconditioning (Class II): 1 hours of preconditioning at 150+0/-10℃, Followed by 48±4 hours of recovery under the standard condition. 恢复: 对于 II 介质试验后, 应在标准条件下恢复 48±4 小时. 才测试. Recovery (Class II): 48±4 hours of recovery under the standard Condition after test.
		B ±10%	
		Y ±20%	
	外观无可见损伤 Appearance: No Significant abnormality		
项目 Item	技术要求 Technical Specification		测试方法和备注 Test Method and Remarks
端头强度	抗拉强度	无引线断裂、松动等可见	固定电容器本体, 沿引线方向步施加力直至 10N, 然后保持 10±1 秒. apply the Force gradually to each lead in the radial direction of the Capacitor until reaching

Terminal Strength	Tensile Strength h	不良 No abnormality Such as cut lead. Or	10N and then applied the force for 10±1 Seconds.				
	弯折强度 Bendin g Strengt h	Looseness.	对电容器引出端施加-0.25Kg 的力，使引线弯曲 90 度，持续 5S，然后回到原始位置，接着反方向操作一次作为一个循环，共重复 2 次。 Each lead wire shall be subjected to a force of 0.25kg and then be bent a angle of 90 degree then Returned to initial position. This operation is Done over a period of 5 second. Then second bend In the opposite direction shall be made, repeat 2 times.				
温度循环 Temperat ure cycle	外观无可见损伤 No significant Abnormality in appearance	容量变化 Capacitance change: I 类介质 Class I: ≤5% or ±0.5pf II 类介质: Class II: B ≤ ±12.5/ % Y: ≤ ±30 %	对于 II 类介质,在试验前应先进行如下预处理:150+0/-10℃ ,1 小时接着在标准条件下恢复 48 ±4 小时。 Preconditioning : As For Class II, dielectric,1 hour Of preconditioning at 150+0/-10℃, followed by 48±4 hours Of recovery under the standard condition. 恢复:对于 II 类介质试验后,应在标准条件下恢复 48±4 小时.后才测试,对于 I 类介质应恢复 1 小时。 Recovery: As For Class II, 48±4 hours of recovery Under the standard condition after test. And for Class I,1 hours of recovery under the standard Condition after test 循环次数: 5 Number of cycle:5 以下为一次循环的条件 Conditions for 1 cycle:				
	损耗角正切 Dissipation Factor: I 类介质:小于原值的 2 倍。 Class I :Not more than twice of initial value. II 类介质 Class II: B: ≤5.0% Y ≤12.5% (CR ≤0.1uF) ≤15.0% (1uF > CR >0.1uF) ≤17.5% (CR >0.1uF)		阶段 Step	温度 (°C) Temperature (°C)			时间 (分钟) Time (min)
			NPO X7R	X5R	Y5V		
			1	常温 Room Temp.			2-3
			2	-55	-25+0/-3	+10	30
			3	常温 Room Temp.			2-3
			4	125	+ 80 + 3/-0	85	30
	绝缘电阻 ≥1000M Ω or 50M Ω .Uf Insulation Resistance: 取较小值 Whichever is smaller		5	常温 Room Temp.			2-3

项目 Item	技术要求 Technical Specification	测试方法和备注 Test Method and Remarks			
高温 负荷 High	外观无可见损伤 No significant abnormality In appearance	温度: Temperature			
	容量变化	NPO X7R	X5R	Y5V	

Temperature Load Rating Test	Capacitance Change: I 类介质 Class I: ≤±3% or ±0.3pF 取较大值 Whichever is larger. II 类介质 Class II: B: ≤±12.5%    Y: ≤±30 % 损耗角正切 Dissipation Factor: I 类介质:小于原值的 2 倍. Class I :Not more than twice of initial value II 类介质 Class II: B: ≤5.0%    Y≤12.5% (CR≤0.1uF) ≤15.0% (1uF>CR>0.1uF) ≤17.5% (CR≥1uF)	125 +3/-0°C	85+3/-0°C
	绝缘电阻 Insulation Resistance: ≥500M Ω or 25M Ω .Uf 取较小值 Whichever is smaller	电压: 1.5 倍额定电压 Applied voltage : 1.5times rated voltage 充放电流不超过 50Ma 时间:1000+48/-0 hours 恢复时间: Recovery Time: I 类介质:24±2 小时 Class I Dielectric: 24±2 hours II 类介质:48±4 小时 Class II Dielectric: 48±4 hours	
耐溶剂性 Solvent Resistance	外观无可见损伤或异常,标记清晰. No defects or abnormalities in Appearance, and legible marking.	溶剂温度:23±5°C Solvent temperature: 23±5°C 将样品浸在溶剂中 1 分钟,用脱脂棉在样品有标志部位刷 10 次,重复 3 次. Put the sample into solvent 1min,and then Take it out and brush sample, notation area 10 times with pledgt, repeat 3times.	

\*以上所示标准条件解释如下:

温度:5~35°C,湿度:45~85%,气压:86~106kpa

\*Note on standard condition: "standard condition" referred to here in should be defined as forllows:5 to 35°C of temperature,45 to 75% of relative humidity, and 86 to 106kpa of atmospheric pressure.

若测试结果有争议时,仲裁试验用标准大气条件为:

温度:25±1°C,相对湿度:48%~52%, 气压:86~106 kpa

\*When there are questions concerning measurement results : In order to provide correlation data, the test should be conducted under a condition of 25 degrees plus/minus1 centigrade of temperature,48% through52% of relative humidity and 86 through 106kpa of atmospheric pressure.