

NOTES 注释:

1. MATERIAL材料:
  - 1.1 HOUSING外壳: THERMOPLASTIC, HIGH TEMP., UL94V-0; COLOR: BLACK.
  - 1.2 CONTACTS触点: COPPER ALLOY.
2. FINISH饰面:
  - 2.1 CONTACT触点: SELECTEIVE GOLD PLATING ON CONTACT AREA. 100µ" MIN. MATTE TIN PLATING ON SOLDER TAILS, 50µ" MIN. NICKEL UNDERPLATING OVERALL.
3. FOR WAVE SOLDER APPLICATION ONLY  
仅适用于波状焊料应用

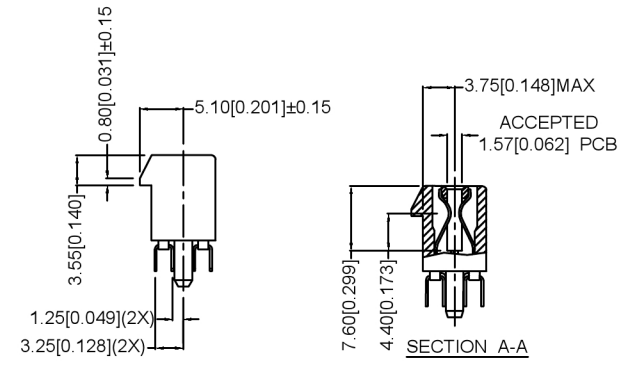

X3160 W V - XX X - 46 V15

- ① ② ③ ④ ⑤ ⑥ ⑦

- ① Series Number
- ② Terminal form: W-Wafer
- ③ Welding Board Angle : V-Stright Angle 180°
- ④ No. of Pins: XX-230 Pin
- ⑤ Tail Length (DIM "E") /B Type :3.1mm ; C Type:2.54mm
- ⑥ Plastic material: PA46/PA9T UL94V-0
- ⑦ Contact Plating:V15-Gold 15"u"

广东星坤科技股份有限公司

DATE	日期
DESCRIPTION	文件工程章

MARK	REVISIONS	DATE	REVISED	APPROVED	ANGLAR	±5°
					L ≤ 4	±0.2
					4 < L ≤ 16	±0.3
					16 < L ≤ 63	±0.4
					L > 63	±0.5
						UNSPECIFIED TOLERANCES



DSND	SCALE: N/A	MODEL TYPE:
DWN	VIEW:	PART NO.: X3160WV-XXX-46V15
CHKD	UNIT: mm/in	DWG NO.: X-X3160WV-XXX-46V15
APPD	SIZE: A4	WEIGHT SHEET REVISION
KKB INDUSTRIAL PRECISION CO., LIMITED		1/1 A0

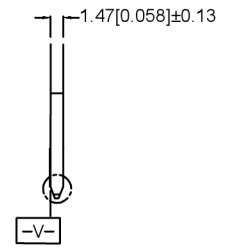
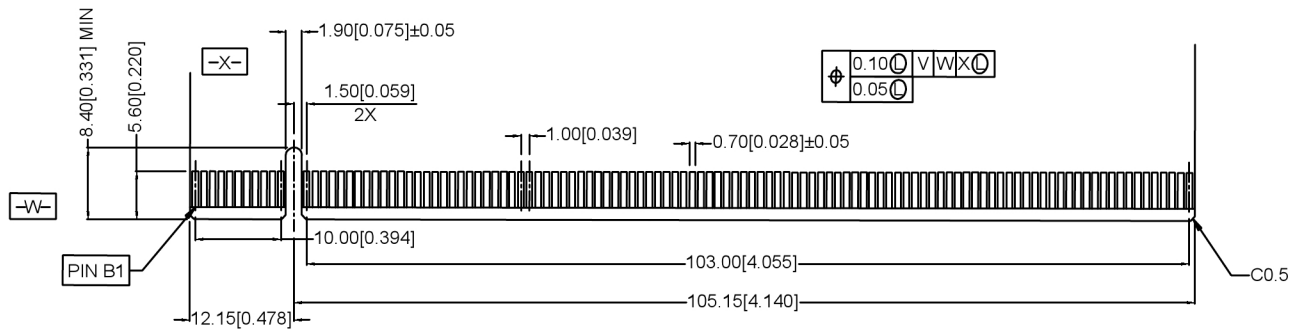

← I/O PANEL DIRECTION PRIMARY (COMPONENT) SIDE  
ADD - IN CARD EDGE - FINGER DIMENSIONS

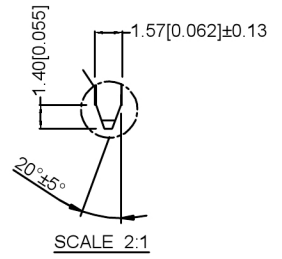
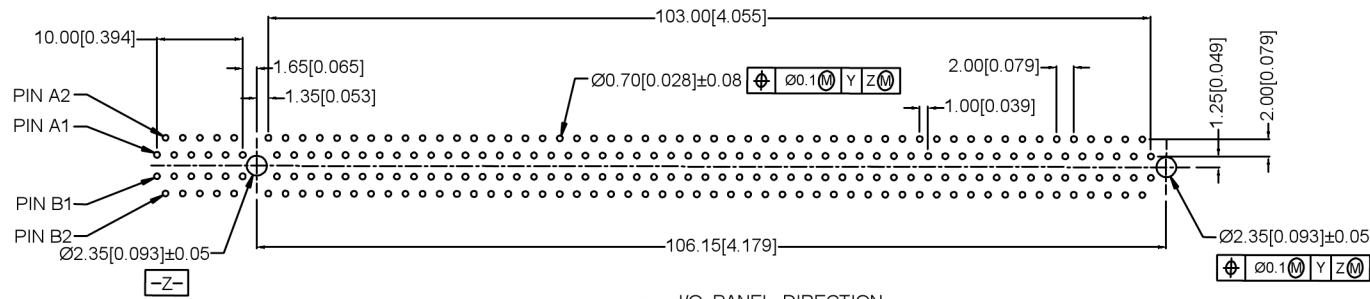

← I/O PANEL DIRECTION  
RECOMMENDED FOOTPRINT



广东星坤科技股份有限公司

Δ*	日期
Δ*	日期
Δ*	日期
MARK	DESCRIPTION
文件	工程章

MARK	DESCRIPTION	DATE	REVISED	APPROVED	UNSPECIFIED TOLERANCES
	REVISIONS				

**XKLB**

**XKLB INDUSTRIAL PRECISION CO., LIMITED**

DSND	SCALE: N/A	MODEL TYPE:
DWN	VIEW:	PART NO.: X3160WV-XXX-46V15
CHKD	UNIT: mm/in	DWG NO.: X-X3160WV-XXX-46V15
APPD	SIZE: A4	WEIGHT SHEET REVISION
		1/1 A0

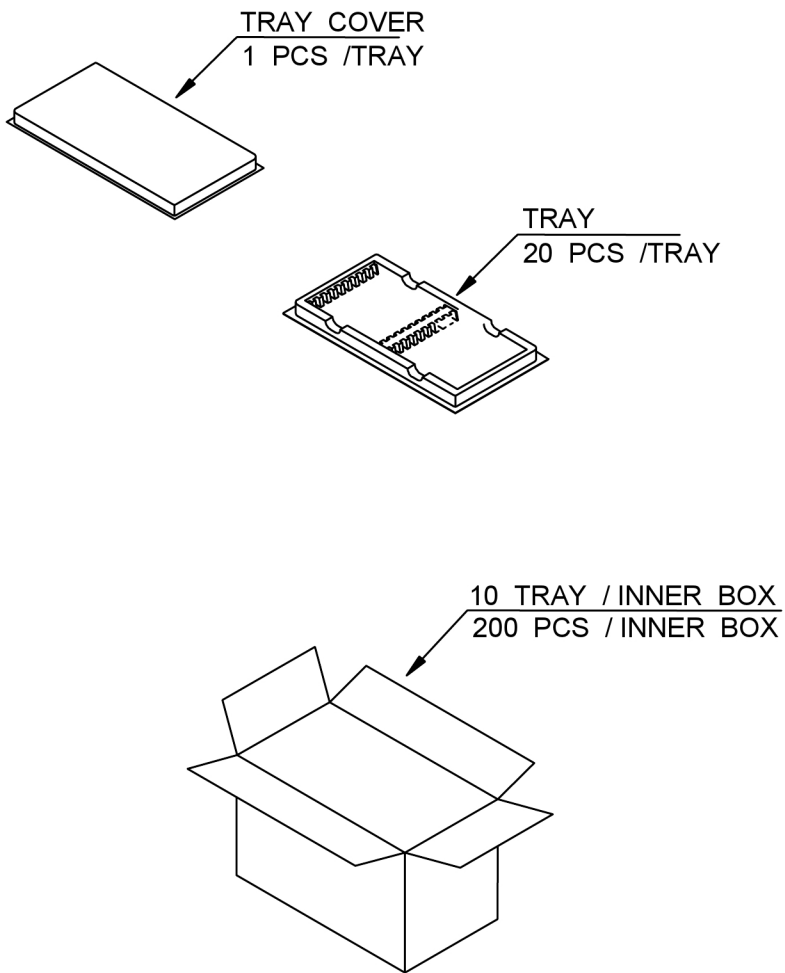

NOTES 注释:

1. TRAY COVER SIZE 托盘盖尺寸: 329.5mm(L)X 170mm(W)X 20mm(H).
2. TRAY SIZE 托盘尺寸: 328.5mm(L)x 170mm(W)x 20mm(H).
3. BOX SIZE 箱体尺寸: 340mm(L)X 187mm(w)x 210mm(H).
4. CARTON SIZE 纸箱规格: 576mm(L)X 350mm(W)X 232mm(H).
5. NET WEIGHT 净重: 8.7 Kg.
6. GROSS WEIGHT 毛重: 10.4 Kg.

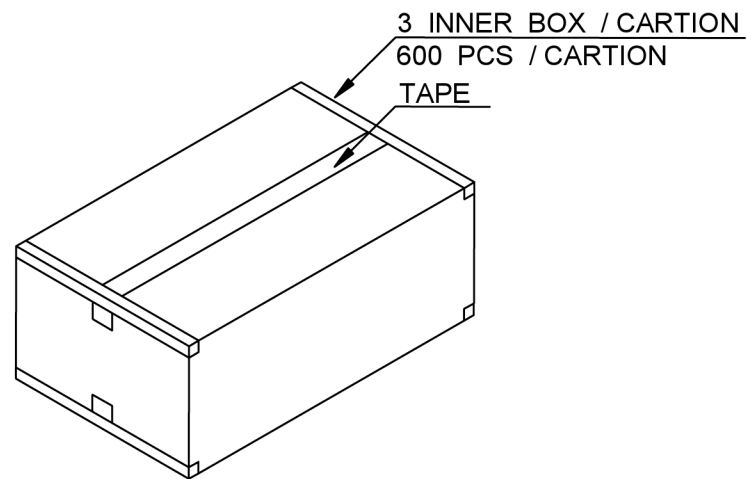

SHIPPING CARTON

广东星坤科技股份有限公司

Δ#	日期
ΔX	日期
ΔX	日期

文件工程章

MARK	DESCRIPTION	DATE	REVISED	APPROVED	UNSPECIFIED TOLERANCES
	REVISIONS				
					ANGLAR ±5°
					L ≤ 4 ±0.2
					4 < L ≤ 16 ±0.3
					16 < L ≤ 63 ±0.4
					L > 63 ±0.5

**XKIB**

XKB INDUSTRIAL PRECISION CO., LIMITED

DSND	SCALE: N/A	MODEL TYPE:
DWN	VIEW:	PART NO.: X3160WV-XXX-46V15
CHKD	UNIT: mm/in	DWG NO.: X-X3160WV-XXX-46V15
APPD	SIZE: A4	WEIGHT SHEET REVISION
		1/1 A0