

REV	ECN NO.	NAME	DATE	TOLERANCE		APPD: Schumi	MAT'L:
				LINEAR	ANGLES		
2	---	Li xiaqin	July,30,2019	X.±0.40	X'.±	UMax 东莞市友贸实业有限公司 DONGGUAN UMAX ENTERPRISE LIMITED	Q'TY:
1	---	Li xiaqin	July,26,2019	.X±0.30	.X'±		
0	---	Li xiaqin	July,16,2019	.XX±0.20	.XX'±		
REV	ECN NO.	NAME	DATE	.XXX±0.10	.XXX'±	DRWN: Li xiaqin	

TITLE: DDR 4, VERTICAL 288P MEMORY SOCKET SMT TYPE			
PART NO. 90411-XXXXXX			
DWG NO. C-90411			
UNITS	SCALE	SHEET	REV
MM	1 : 1	1 OF 5	2

NOTES:

1. MATERIAL :

- 1.1 HOUSING: PA9T, HF, UL94 V-0, COLOR: SEE PART NO..
- 1.2 LATCH: PA9T, HF, UL94 V-0, COLOR: SEE PART NO..
- 1.3 CONTACTS: COPPER ALLOY.
- 1.4 BOARDLOCKS AND TAB: SUS.

2. FINISH :

2.1 CONTACT

- [SEE PART NO..] GOLD PLATING ON THE CONTACT AREA.
- 2.54um [100u"] MIN. MATTE-TIN PLATING ON THE SOLDERING AREA.
- 1.27um [50u"] MIN. NICKEL UNDERPLATING OVERALL.

PART NO..

90411- XX X X X X

CONTACT AREA PLATING
 15: 15u" Au
 30: 30u" Au

BOARDLOCK TYPE
 BLANK:BOARDLOCK
 1:TAB
 LATCH TYPE
 1: SHORT LATCH
 2: LONG LATCH
 3: MIDDLE LATCH
 LATCH COLOR
 1: BLACK
 2: NATURAL
 HOUSING COLOR
 1: BLACK
 2: NATURAL

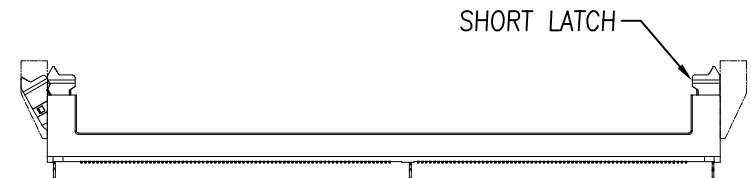
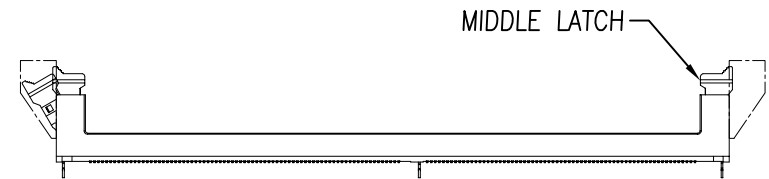
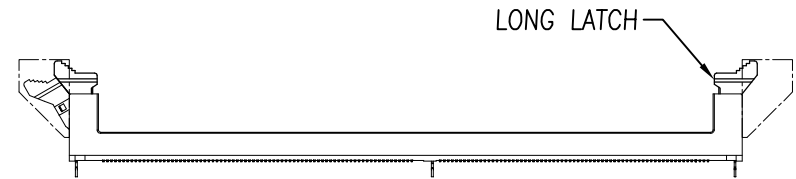

147.30	162.00	LONG
142.35	156.00	MIDDLE
140.80	152.00	SHORT
DIM "B"	DIM "A"	LATCH TYPE

TOLERANCE		UMax 东莞市友贸实业有限公司 DONGGUAN UMAX ENTERPRISE LIMITED	
LINEAR	ANGLES	APPD: Schumi	MAT'L:
X.±	X'.±	CHKD: Lei songping	FINISH:
.X±0.30	.X'±	DRWN: Li xiaqin	Q'TY:
.XX±0.20	.XX'±		
.XXX±	.XXX'±		

TITLE: DDR 4, VERTICAL 288P MEMORY SOCKET SMT TYPE			
PART NO. 90411-XXXXXX		DWG NO. C-90411	
UNITS MM	SCALE 1 : 1	SHEET	REV
		2 OF 5	2

SEE SHEET 1			
REV	ECN NO.	NAME	DATE

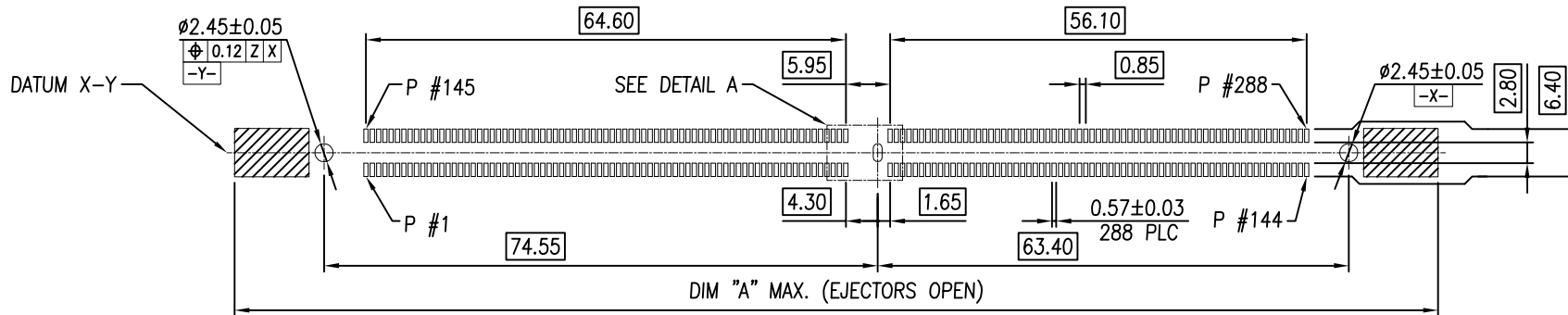

-Z-

RECOMMENDED PCB LAYOUT (TOP VIEW)

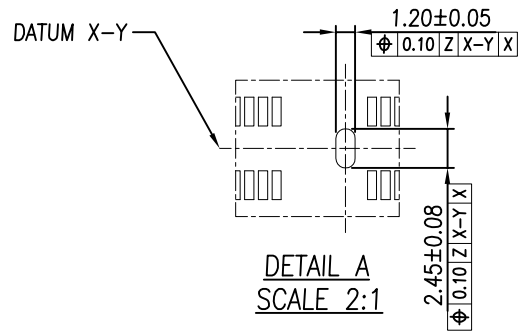

				TOLERANCE		UMax 东莞市友贸实业有限公司 conn DONGGUAN UMAX ENTERPRISE LIMITED		TITLE: DDR 4, VERTICAL 288P MEMORY SOCKET SMT TYPE					
				LINEAR	ANGLES			PART NO. 90411-XXXXXX					
	SEE SHEET 1			X.±	X'.±	APPD: Schumi	MAT'L:	DWG NO. C-90411					
REV	ECN NO.	NAME	DATE	.XX±	.XX'.±	CHKD: Lei songping	FINISH:			UNITS	SCALE	SHEET	REV
				.XXX±	.XXX'.±	DRWN: Li xiaqin	Q'TY:			MM	1 : 1	3 OF 5	2

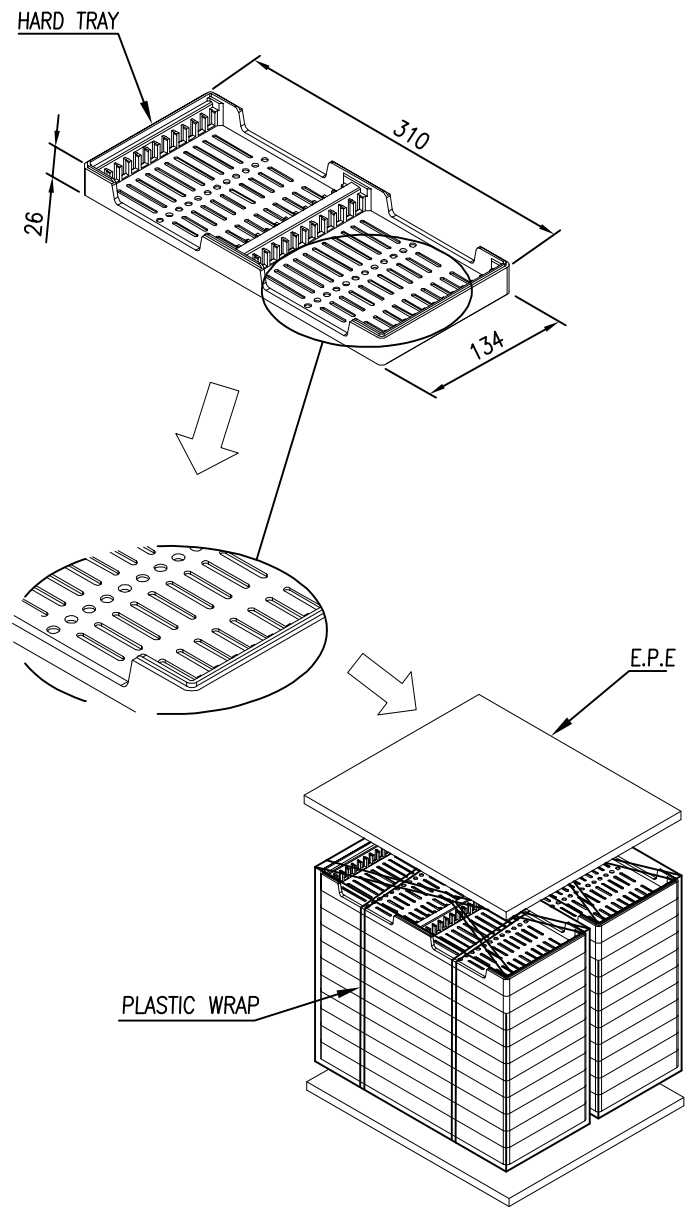

NOTES :

- 1. MATERIAL :
 - TRAY: HIPS, COLOR: BLACK.
 - BOX: CORRUGATED FIBER
 - TRANSPARENT BAG: PE, SIZE: 660mm*600mm*0.08mm

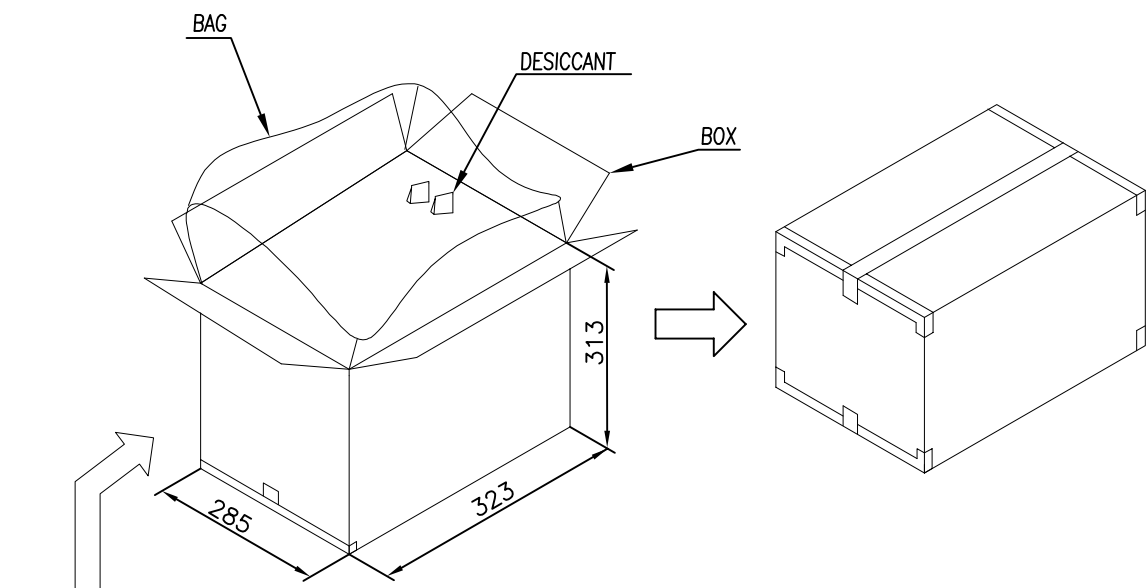

PCS/ TRAY	TRAY/ BOX	PCS/ BOX	NET WEIGHT	GROSS WEIGHT
24	20	480	2.55 KG	5.75 KG

REV	SEE SHEET 1	NAME	DATE
	ECN NO.		

TOLERANCE	
LINEAR	ANGLES
X.±	X'±
.X±0.30	.X'±
.XX±0.20	.XX'±
.XXX±	.XXX'±

UMax 东莞市友贸实业有限公司
DONGGUAN UMAX ENTERPRISE LIMITED

APPD: Schumi MAT'L:

CHKD: Lei songping FINISH:

DRWN: Li xiaqin Q'TY:

TITLE: DDR 4, VERTICAL
288P MEMORY SOCKET SMT TYPE

PART NO. 90411-XXXXXX

DWG NO. C-90411

		UNITS	SCALE	SHEET	REV
		MM	1 : 1	5 OF 5	2