



REV.	ECN NO OR DESCRIPTION	REVISED	DATE

备注:

1. 材质:

1.1 胶芯: LCP+30%G.F

1.2 端子: C7025, T=0.15mm; 镍底, 镀金

1.3 外壳: 不锈钢, T=0.17mm; 表面镀镍

1.4 卡钩: 不锈钢, T=0.30mm; 表面镀锡

1.5 弹片: 不锈钢, T=0.10mm

2. 主要特性:

2.1 额定电流: 3A FOR VBUS;
1.25A FOR GND;
0.25A FOR OTHER.

2.2 接触阻抗: 40mΩ MAX

2.3 绝缘阻抗: 100MΩ MIN

2.4 耐压测试: 100V AC

2.5 沾锡性: 温度245±5℃, 时间5±0.5s

2.6 整体插入力: 5~20N

整体拔出力: 8~20N

耐久后拔出力: 6~20N

2.7 使用寿命: 10000次

2.8 工作温度: -25℃~+80℃

A1	GND	B12	GND
A2	SSTXP1	B11	SSRXP1
A3	SSTXN1	B10	SSRXN1
A4	VBUS	B9	VBUS
A5	CC1	B8	SBU2
A6	DP1	B7	DN2
A7	DN1	B6	DP2
A8	SBU1	B5	CC2
A9	VBUS	B4	VBUS
A10	SSRXN2	B3	SSTXN2
A11	SSRXP2	B2	SSTXP2
A12	GND	B1	GND
PIN	SIGNAL NAMF	PIN	SIGNAL NAMF

UNLESS OTHERWISE SPECIFIED TOLERANCES

东莞市汉博电子科技有限公司
DONGGUAN HANBO TECHNOLOGY CO., LTD

DECIMALS: ANGLES:

X :±0.30 X :±2°

X.X :±0.20 X.X :±1°

X.XX :±0.10

TITLE	USB TYPE-C/M SMT 铜合式鱼叉脚厚3.0		
DWN	xiong	PART NO.	TC-004
CHKD	lee	SCALE:1:1	UNIT: mm
APVD	wang	SIZE: A4	SHEET:10F 1
REV: A4			

CUSTOMER COPY

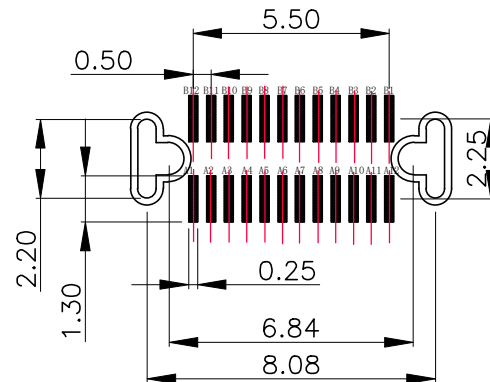
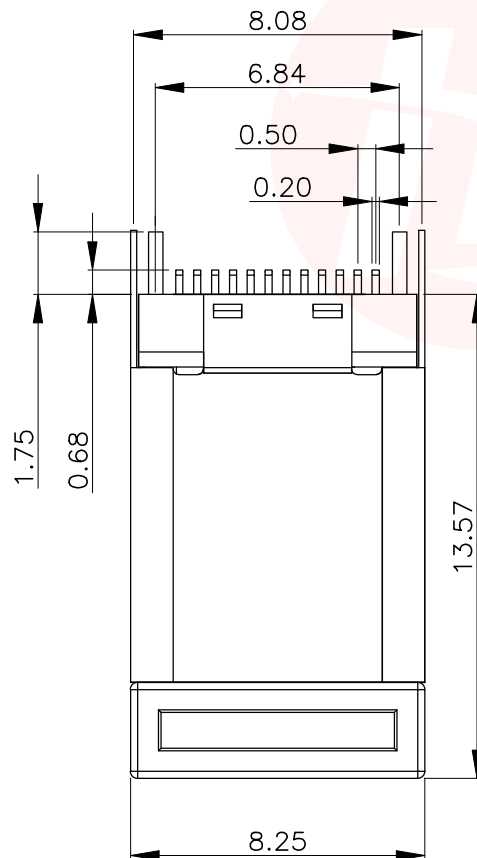
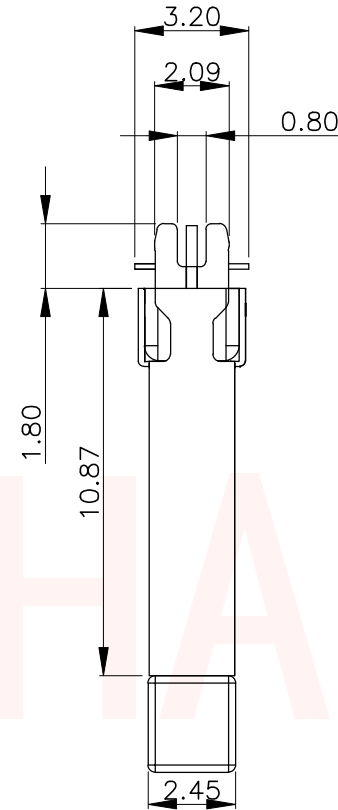
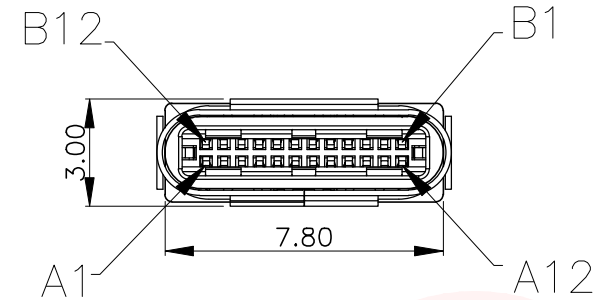

RECOMMENDED P.C.B LAYOUT TOP VIEW
TOLERANCE UNSPECIFIED ±0.05mm