

**Product Specification**

# 深圳市臺華達科技有限公司

SHENZHEN THD Electronics Co., Ltd.

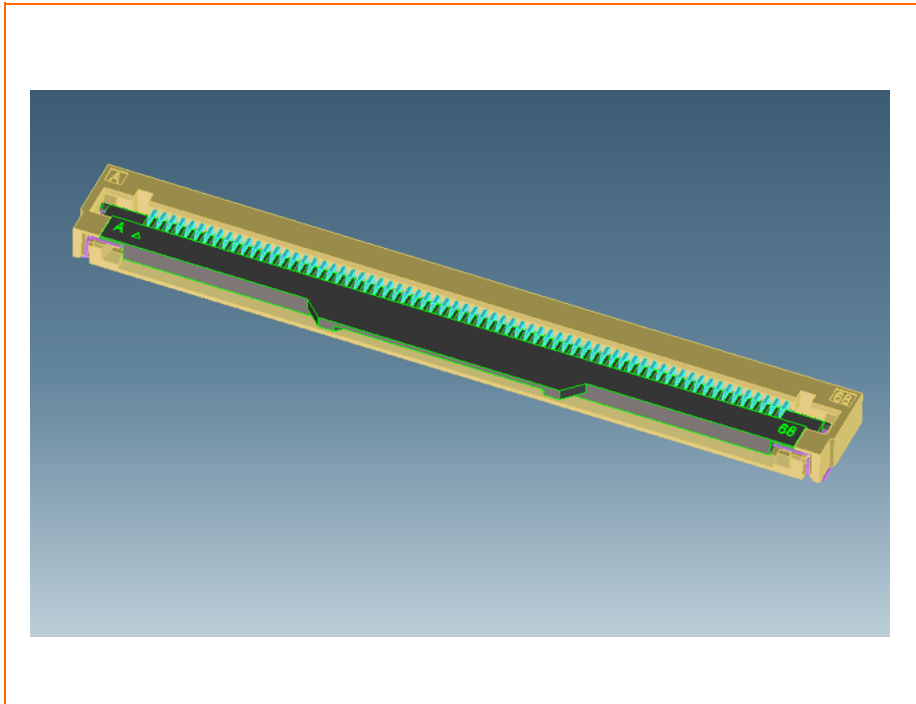

Product.No

**THD0530-96CL-GF**

**Pitch=0.50mm,H=2.1 mm FPC Connector (Front-Flip Lower Contact)**

A	Release
Rev.	Description

**Approved Signatures**

■Prepared By : JIM	■Date: 2022.10.13
■Checked By : JIM	■Date: 2022.10.13
■Approved By : PETE	■Date: 2022.10.13

## ■ Scope

This specification covers the 0.5 mm Pitch FPC Connector THD0530 series.

## ■ Ordering information

THD0530 - xx CL - GF

①                      ②                      ③                      ④

①	Series name : THD0530	④	Plating : GF= 1μ"~3μ" Gold Flash G3= 3μ" Gold over Nickel G5= 5μ" Gold over Nickel SN= Tin(Lead Free) over Nickel
②	Number of contacts : 40 TO 96		
③	Contact type : CL:Lower contact CU:Upper contact		

## ■ Rating

Item	Standard
Voltage Rating(Max.)	50V AC
Current Rating(Max.)	0.5A DC
Operating Temperature Range	-25°C ~ +85°C (Including terminal temperature rise)

## ■ Material

Housing	Actuator	Terminal	Solder pin	Plating
L.C.P (UL94V-0)	L.C.P (UL94V-0)	Copper alloy	Copper alloy	TIN over Nickel
Color : White	Color : Black			

## ■ Performance

Item	Test Condition	Specification	
Contact Resistance	Mate applicable FPC and measure by dry circuit, 20mV Max, 10mA.	30 mΩ Max.	
Insulation Resistance	Mate applicable FPC and apply 500V DC between adjacent terminal or ground.	100 MΩ Min.	
Dielectric Strength	Mate applicable FPC, apply 250V AC(rms) for 1 minute between adjacent terminal or ground.	No Breakdown	
FPC Retention Force	Insert the actuator, pull the FPC at a rate of 25±3mm per minute.	Per pin x 0.045N Min.	
Terminal Retention Force	Apply axial pull out force at the rate of 25±3 mm/minute on the terminal assembled in the housing.	Per pin x 0.1Kgf {0.45N} Min.	
Vibration	Mate connectors and subject to the following vibration conditions, for period of 2 hours in each of 3 mutually perpendicular axes, passing DC 1mA during the test.  Amplitude : 1.5mm P-P Frequency : 10~55~10 Hz in 1 minute. Duration : 2 hours in each of X,Y,Z axes.	Appearance	No Damage
		Contact Resistance	100 mΩ Max.
		Discontinuity	1 μsec Max.
Shock	Mate applicable FPC and subject to the following shock conditions. 3 times of shocks shall be applied for each 6 directions along 3 mutually perpendicular axes, passing DC 1 mA current during the test.  Peak value : 490m/s <sup>2</sup> {50G}	Appearance	No Damage
		Contact Resistance	100 mΩ Max.
		Discontinuity	1 μsec Max.
Salt Spray	Mate applicable FPC and expose to the following salt mist conditions. Upon completion of the exposure period, salt deposits shall be removed by a gentle wash or dip in running water, after which the specified measurements shall be performed.  NaCl solution Concentration : 5 ± 1% Spray time : 24 ± 4 hours Ambient temperature : 35 ± 2°C	Appearance	No Damage
		Contact Resistance	100 mΩ Max.

Item	Test Condition	Specification	
Heat Resistance	Mate applicable FPC and expose to 85±2°C for 96 hours. Upon completion of the exposure period, the test specimens shall be conditioned at ambient room conditions for 1 to 2 hours, after which the specified measurements shall be performed.	Appearance	No Damage
		Contact Resistance	100 mΩ Max.
Cold Resistance	Mate applicable FPC and expose to -40±2°C for 96 hours. Upon completion of the exposure period, the test specimens shall be conditioned at ambient room conditions for 1 to 2 hours, after which the specified measurements shall be performed.	Appearance	No Damage
		Contact Resistance	100 mΩ Max.
Humidity	Mate applicable FPC and expose to 60 ± 2°C, relative humidity 90 to 95% for 96 hours. Upon completion of the exposure period, the test specimens shall be conditioned at ambient room conditions for 1 to 2 hours, after which the specified measurements shall be performed.	Appearance	No Damage
		Contact Resistance	100 mΩ Max.
		Dielectric Strength	No Breakdown
		Insulation Resistance	50 MΩ Min.
Temperature Rise	Mate applicable FPC and measure the temperature rise of contact when the maximum AC rated current is passed.	Temperature rise	30°C Max.
Temperature Cycling	Mate applicable FPC and subject to the following conditions for 5 cycles. Upon completion of the exposure period, the test specimens shall be conditioned at ambient room conditions for 1 to 2 hours, after which the specified measurements shall be performed. 1 cycle a) -55±3°C      30minutes b) +85±3°C      30minutes (Transit time shall be with in 3 minutes)	Appearance	No Damage
		Contact Resistance	100 mΩ Max.
Solderability	Tip of solder tails and fitting nails into the molten solder (held at 245±5°C) up to 0.1mm from the bottom of the housing for 3±0.5 seconds.	Solder Wetting	95% of immersed area must show no voids, pin holes.
Resistance to Soldering	When reflowing refer to Infrared reflow condition <u>Soldering iron method</u> 0.2mm from terminal tip and fitting nail tip. Soldering time : 5 seconds Max. Solder temperature : 370~400°C	Appearance	No Damage

### ■ Recommended Temperature Profile

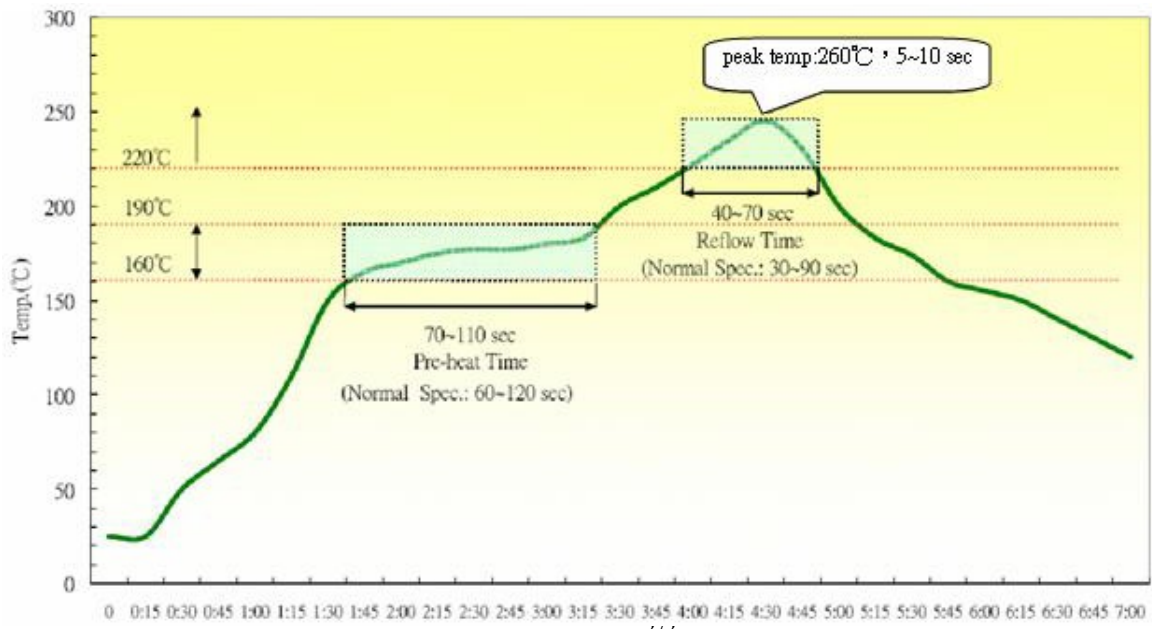

NOTES:

1.HOUSING: LCP HIGH-TEMP THERMOPLASTIC UL94V-0 COLOR:NATURE  
 2.ACTUATOR: LCP HIGH-TEMP THERMOPLASTIC UL94V-0 COLOR:BLACK  
 3.TERMINAL:PHOSPHOR BRONZE  
 PLATING:1\*“GOLD PLATING OR 100~150\*“TIN(LEAD FREE)  
 OVERALL 50~100\*“NICKEL UNDER PLATED.

4.FITTING NAIL:PHOSPHOR BRONZE  
 PLATING:100~150\*“TIN(LEAD FREE)  
 OVERALL 50~100\*“NICKEL UNDER PLATED.

5.SPECIFICATION:  
 CURRENT RATING: 0.5A 50V AC/DC  
 CONTACT RESISTANCE: 30mΩ MAX  
 INSULATION RESISTANCE: 100MΩ AT 500V DC  
 OPERATING TEMPERATURE RANGE: -40°C~85°C  
 WITHSTANDING VOLTAGE: 500V AC/minute

6.CODING INFORMATION: THD0530-xxCl-GF  
 GOLD PLATING  
 NO. OF CONTACTS  
 0.5PITCH 2.1H R/A SMT Connector  
 TAHHUDA FPC CONNECTOR SERIES

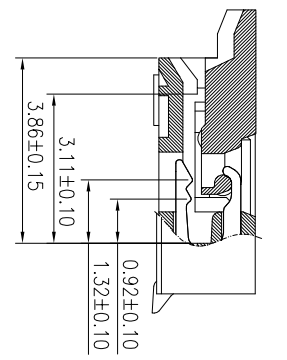
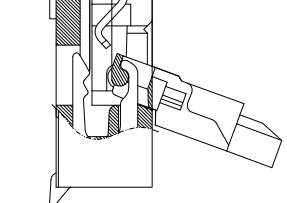
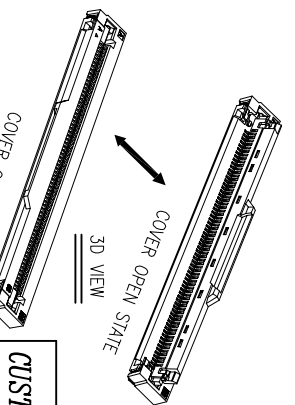
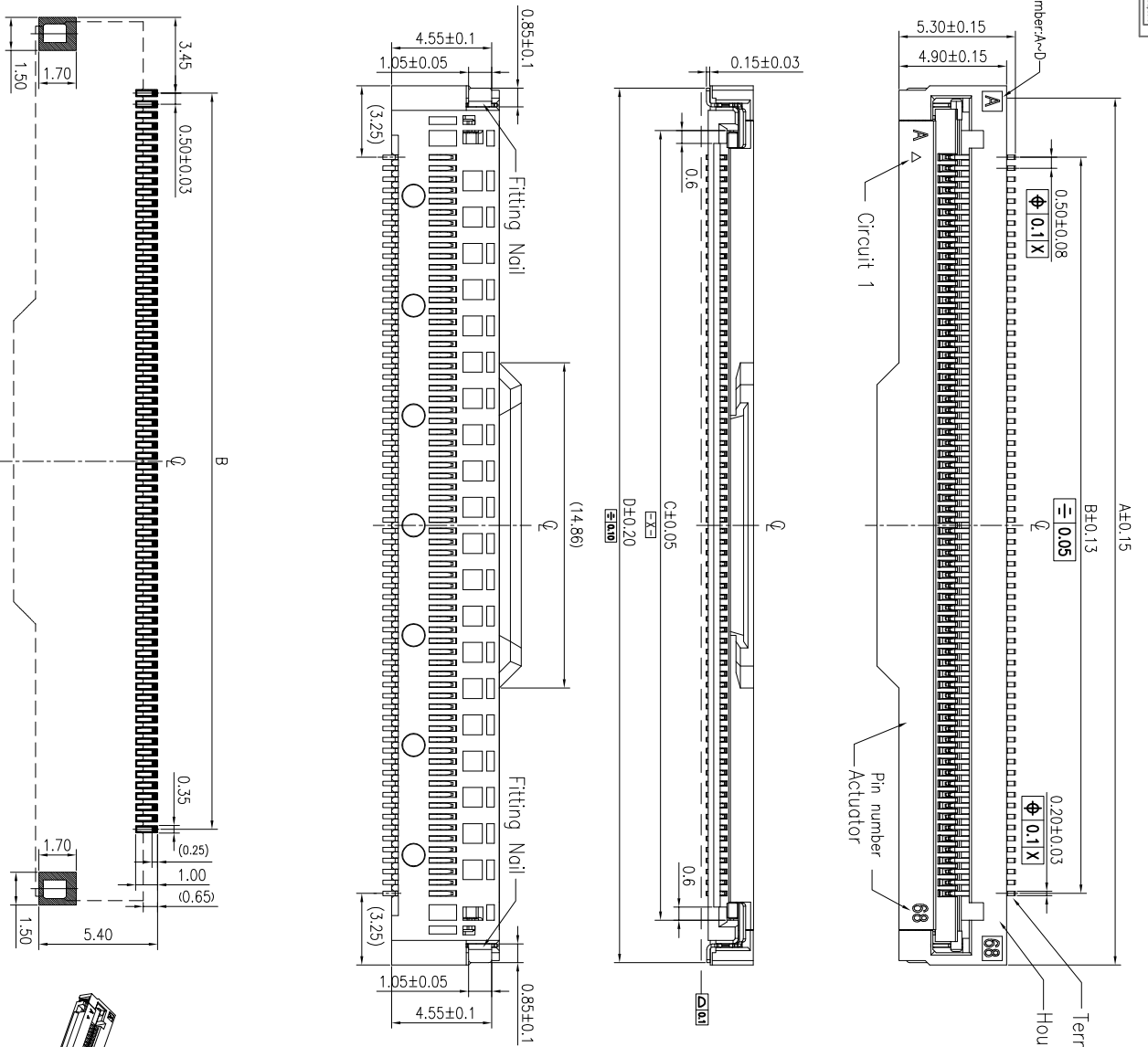

NO. of contacts	Dimensions			
	A.	B.	C.	D.
40	26.00	19.50	21.93	25.80
50	31.00	24.50	26.93	30.80
60	36.00	29.50	31.93	35.80
68	40.00	33.50	35.93	39.80
80	46.00	39.50	41.93	45.80
96	54.00	47.50	49.93	53.80

**CUSTOMER**  
**SHENZHEN SHI THD TECHNOLOGY CO., LTD.**

**GENERAL TOLERANCE UNLESS OTHERWISE SPECIFIED**  
 XX ±0.25  
 XXX ±0.20  
 XXXX ±0.15  
 ANG. ±2°

**DRAWN:** Kevin  
**CHECKED:** 2022.10.13  
**APPROVED:** 2022.10.13  
**TITLE:** LOWER CONTACT R/A SMT CONN.  
(onover version:zhongwen)

**PART NO.** THD0530-xxCl-GF  
**SCALE:** 1:1  
**SIZE:** A4  
**REV:** A

**REVISIONS**

REV.	REVISIONS	CHK	DATE

RECOMMENDED PCB PATTERN DIM.  
 TOLERANCE : ±0.05

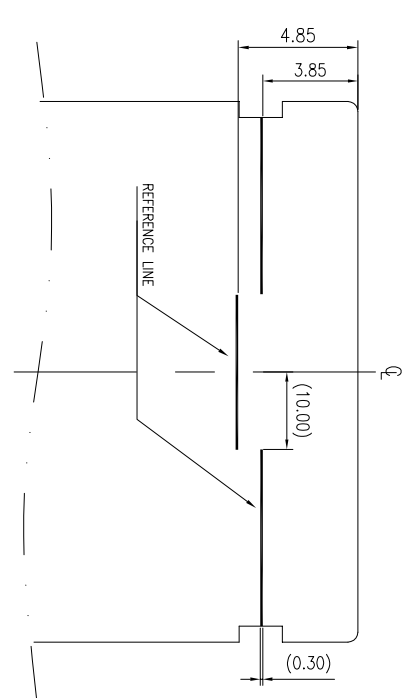
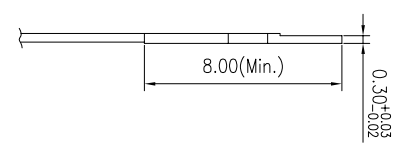
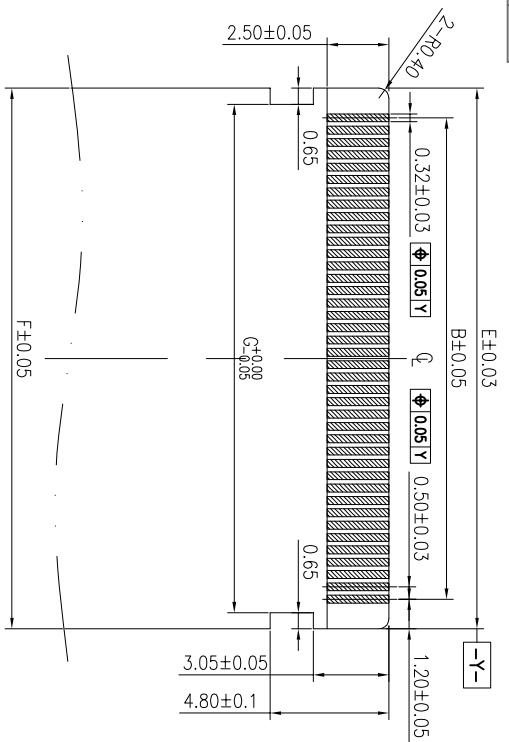

APPLICABLE FPC/FFC

蓝白裸线 (不接地)

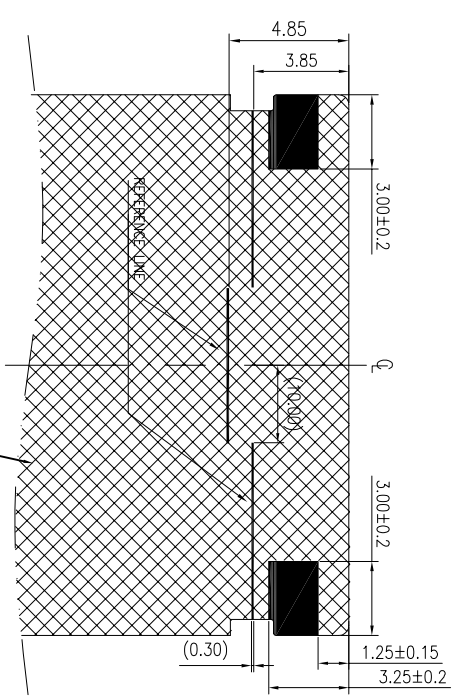
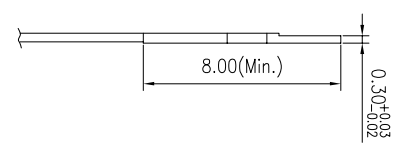
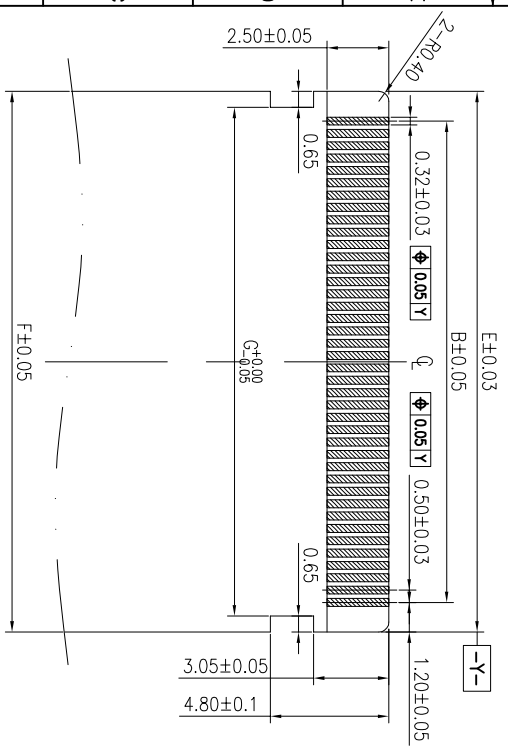

APPLICABLE FPC/FFC

一体补强板铝箱FPC线

一体补强板铝箱FPC线

NO. of contacts	Dimensions			
	B.	E.	F.	G.
40	19.50	21.90	20.60	21.90
50	24.50	26.90	25.60	26.90
60	29.50	31.90	30.60	31.90
68	33.50	35.90	34.60	35.90
80	39.50	41.90	40.60	41.90
96	47.50	49.90	48.60	49.90

**CUSTOMER**  
SHENZHEN SHI THD TECHNOLOGY CO., LTD.

**SHENZHEN SHI THD TECHNOLOGY CO., LTD.**

THD0530-XXCL-GF

GENERAL TOLERANCE UNLESS OTHERWISE SPECIFIED  
XX ±0.25  
XXX ±0.20  
XXX ±0.15  
ANG. ±2'

DRAWN: Kavin  
CHECKED: 散  
DATE: 2022.10.13

TITLE: 0.5PITCH 2.1H FPC LOWER CONTACT R/A SMT CONN. (narrow version) (shenzhen)

SCALE: 1:1  
SHEET: 2/2  
UNIT: mm

REV: A

APPLICABLE FPC/FFC

一体补强板铝箱FPC线

一体补强板铝箱FPC线

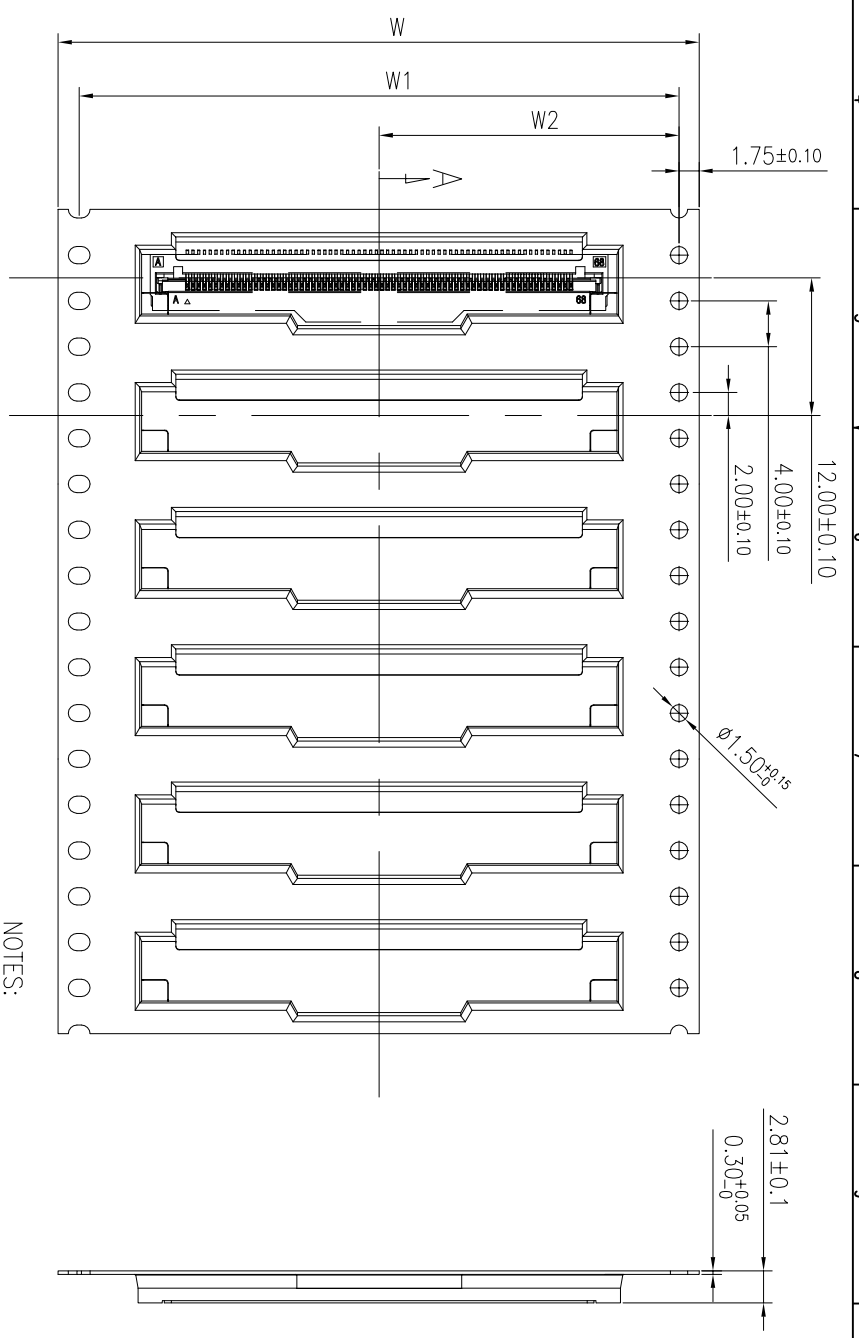
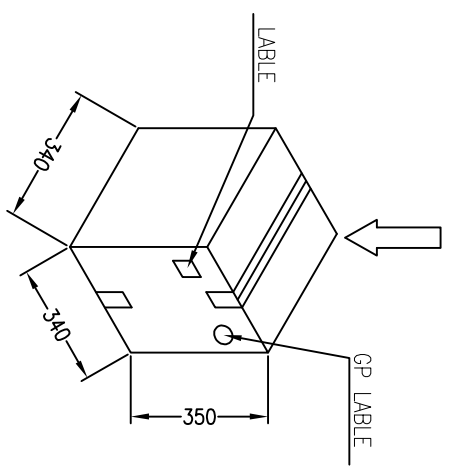
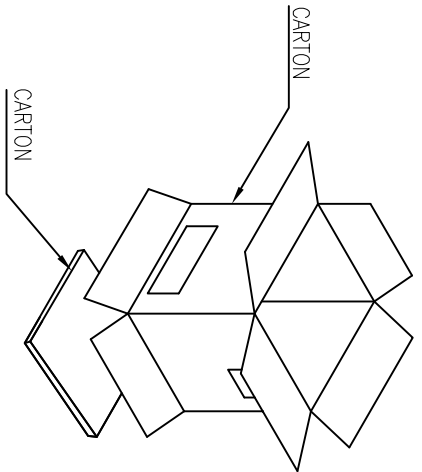
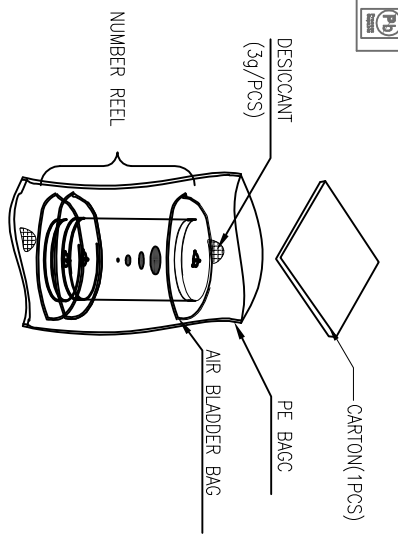

REEL DIM

- NOTES:
- 1.Component load per 13" reel:2000 pcs
  - 2.Material: white conductive polystyrene alloy.
  - 3.Thickness:0.3±0.05mm
  - 4.All dimensions meet EIA-481-C requirements

No.of Contacts	DIM			REEL (CARTON)	SUM(PCS)
	W	W1	W2		
THD0530 40pin~50pin	44	20.2	40.4	6	12000
THD0530 51 pin~74pin	56	52.4	26.2	5	10000
THD0530 75pin~96pin	72	68.4	34.2	4	8000

<b>CUSTOMER</b>		<b>SHENZHEN SHI THD TECHNOLOGY CO., LTD.</b>	
GENERAL TOLERANCE UNLESS OTHERWISE SPECIFIED		DRAWN: 蔡華達	PART NO: THD0530-XXCL-GF
XX	±0.25	CHECKED: 胡文	TITLE: 0.5 PITCH 2.1H FPC CONN.
XXX	±0.20	APPROVED: 黃德進	(narrow version)
XXX	±0.10	DATE: 2022.10.18	SCALE: 1:1
ANG.	±3°	SHEET: 1/1	SIZE: A4
REV.	REVISIONS	CHK	DATE