

SECTION A-A
SCALE 1:1

Note:

- Material:
 - Housing: thermoplastic high temp.UL94V-0; Color: natural.
 - Latch: thermoplastic high temp.UL94V-0; Color: black.
 - Terminal: copper alloy.
 - Fitting Nail: copper alloy.

2. Finish:

- Terminal:
 - Underplating: Au/matt Tin overall.
- Fitting Nail:
 - Underplating: matt Tin overall.

3. Product must comply HF RoHS specification.

4. Product No:

AFA24-S ** F * * - **
 CKTS _____
 CONTACTS TYPE _____
 F:Lower _____
 PLATING _____
 1:Gold flash 1u"
 2:Gold flash 2u"
 3:Gold flash 3u"
 B:Bright-Tin 90-120u"
 C:Matt-Tin 90-120u"
 REMARKS
 HF:Halogen free
 PACKING
 A:Tape&Reel
 C:Tube

CKTS	DIM A	DIM B	DIM C	DIM D
4	3.00	5.10	8.00	8.10
5	4.00	6.10	9.00	9.10
6	5.00	7.10	10.00	10.10
7	6.00	8.10	11.00	11.10
8	7.00	9.10	12.00	12.10
9	8.00	10.10	13.00	13.10
10	9.00	11.10	14.00	14.10
11	10.00	12.10	15.00	15.10
12	11.00	13.10	16.00	16.10
13	12.00	14.10	17.00	17.10
14	13.00	15.10	18.00	18.10
15	14.00	16.10	19.00	19.10
16	15.00	17.10	20.00	20.10
17	16.00	18.10	21.00	21.10
18	17.00	19.10	22.00	22.10
19	18.00	20.10	23.00	23.10
20	19.00	21.10	24.00	24.10
21	20.00	22.10	25.00	25.10
22	21.00	23.10	26.00	26.10
23	22.00	24.10	27.00	27.10
24	23.00	25.10	28.00	28.10
25	24.00	26.10	29.00	29.10
26	25.00	27.10	30.00	30.10
27	26.00	28.10	31.00	31.10
28	27.00	29.10	32.00	32.10
29	28.00	30.10	33.00	33.10

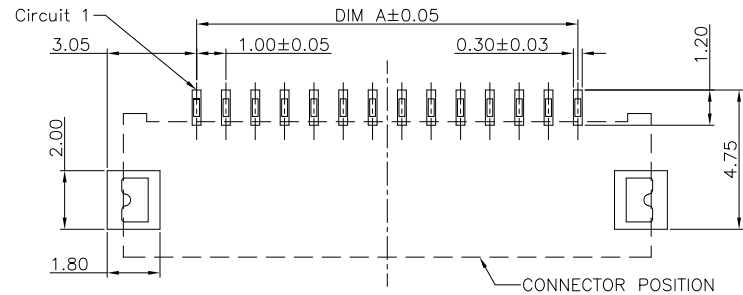
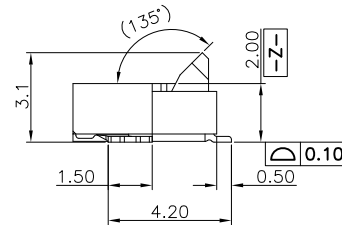
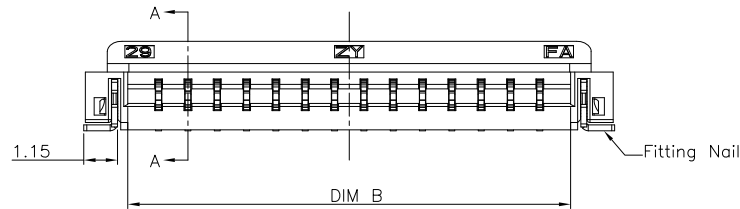

RECOMMENDED P.C.B. PATTERN LAYOUT

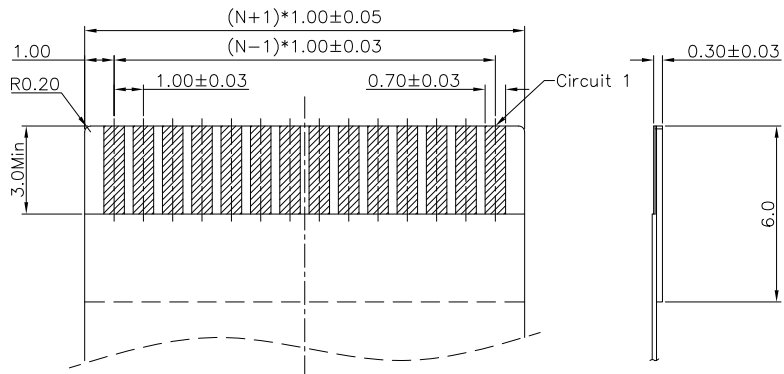

RECOMMENDED FPC/FFC DIMENSION

CUSTOMER DRAWING		深圳市钜硕电子有限公司 SHENZHEN JUSHUO ELECTRONIC CO.,LTD	
Tolerance Unspecified (未注公差)	Size(图幅): A4	Product Name(产品名称): 1.0Pitch H=2.0 FPC Back-Flip R/A Type1 SMT CONN	
0.0 ±0.15 0° ±5°	Unit(单位): MM	Product No(产品料号): AFA24-S**F**-*	
0.00 ±0.10 0° ±3°	Scale(比例): 1:1	Designer(设计): 张孝雄	Checked(审核):
0.000 ±0.05 0° ±1°	Page(页数): 1 OF 1	Approved(核准):	
Project View (投影视角)	Rev(版本): A		
Rev 版本	Change Description 变更内容	Date 日期	Revisor 制/修订人
A	初版发行	2018/07/25	张孝雄

