



# AiP74LVC1G3157

## 2-channel Analog

### Multiplexer/Demultiplexer

# Product Specification

**Specification Revision History:**

Version	Date	Description
2020-05-A1	2020-05	New
2021-09-A2	2021-09	Modify ambient temperature to -40°C~+105°C and add electrical characteristics of -40°C~+105°C
2021-10-A3	2021-10	Modify ordering information
2021-12-A4	2021-12	Modify ordering information
2022-03-A5	2022-03	Modify ordering information note 1
2023-01-A6	2023-01	Add XSON6 packaging form; update package information



## 1、 General Description

The AiP74LVC1G3157 provides one analog multiplexer/demultiplexer with one digital select input (S), two independent inputs/outputs (Y0, Y1) and a common input/output (Z).

Schmitt trigger action at the select input makes the circuit tolerant of slower input rise and fall times across the entire  $V_{CC}$  range from 1.65V to 5.5V.

### Features:

- Wide supply voltage range from 1.65V to 5.5V
- Very low ON resistance:
  - 7.5 $\Omega$  (typical) at  $V_{CC}=2.7V$
  - 6.5 $\Omega$  (typical) at  $V_{CC}=3.3V$
  - 6 $\Omega$  (typical) at  $V_{CC}=5V$
- Switch current capability of 32mA
- Break-before-make switching
- CMOS low power consumption
- TTL interface compatibility at 3.3V
- Control input accepts voltages up to 5.5V
- Specified from -40°C to +105°C
- Packaging information: SOT-23-6/SOT-363/XSON6

### Ordering Information:

#### Reel packing specifications:

Part number	Packaging form	Marking code	Reel quantity	Boxed reel quantity	Notes
AiP74LVC1G3157GB236.TR	SOT-23-6	CNXX	3000 PCS/reel	30000 PCS/box	Dimensions of plastic enclosure: 2.9mm×1.6mm Pin spacing: 0.95mm
AiP74LVC1G3157GC363.TR	SOT-363	CNXX	3000 PCS/reel	30000 PCS/box	Dimensions of plastic enclosure: 2.1mm×1.3mm Pin spacing: 0.65mm
AiP74LVC1G3157EA6.TR	XSON6	CNXX	5000 PCS/reel	25000 PCS/box	Dimensions of plastic enclosure: 1.45mm×1.0mm Pin spacing: 0.5mm

Note 1: “XX” refers to variable content, meaning year and package batch serial number.

Note 2: If the physical information is inconsistent with the ordering information, please refer to the actual product.



## 2、Block Diagram And Pin Description

### 2.1、Block Diagram

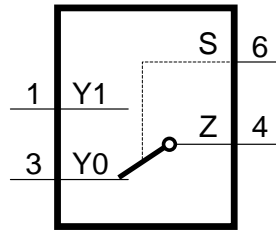

Figure 1. Logic symbol

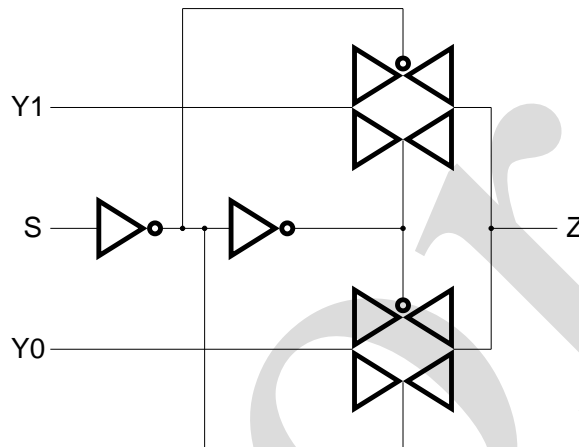
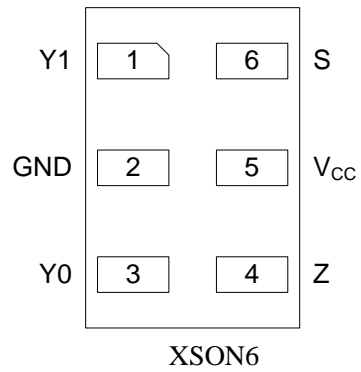
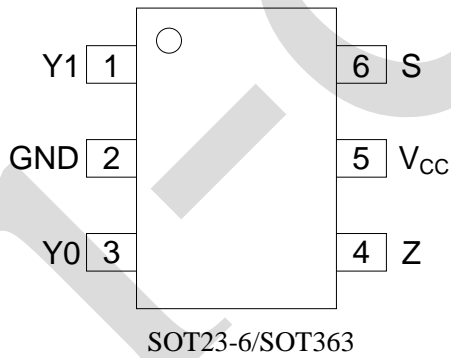

Figure 2. Logic diagram

### 2.2、Pin Configurations





## 2.3、Pin Description

Pin No.	Pin Name	Description
1	Y1	independent input or output
2	GND	ground (0 V)
3	Y0	independent input or output
4	Z	common output or input
5	V <sub>CC</sub>	supply voltage
6	S	select input

## 2.4、Function Table

Input S	Channel on
L	Y0
H	Y1

Note: H=HIGH voltage level; L=LOW voltage level.

## 3、Electrical Parameter

### 3.1、Absolute Maximum Ratings

(T<sub>amb</sub>=25°C, All voltage referenced to GND, unless otherwise specified)

Characteristic	Symbol	Conditions	Min.	Max.	Unit
supply voltage	V <sub>CC</sub>	-	-0.5	+6.5	V
input voltage	V <sub>I</sub>	- <sup>[1]</sup>	-0.5	+6.5	V
input clamping current	I <sub>IK</sub>	V <sub>I</sub> <-0.5V or V <sub>I</sub> >V <sub>CC</sub> +0.5V	-50	-	mA
switch clamping current	I <sub>SK</sub>	V <sub>I</sub> <-0.5V or V <sub>I</sub> >V <sub>CC</sub> +0.5V	-	±50	mA
switch voltage	V <sub>SW</sub>	enable and disable mode <sup>[2]</sup>	-0.5	V <sub>CC</sub> +0.5	V
switch current	I <sub>SW</sub>	V <sub>SW</sub> >-0.5V or V <sub>SW</sub> <V <sub>CC</sub> +0.5V	-	±50	mA
supply current	I <sub>CC</sub>	-	-	100	mA
ground current	I <sub>GND</sub>	-	-100	-	mA
storage temperature	T <sub>stg</sub>	-	-65	+150	°C
total power dissipation	P <sub>tot</sub>	-	-	250	mW
soldering temperature	T <sub>L</sub>	10s	260		°C

Note:

[1] The minimum input voltage rating may be exceeded if the input current rating is observed.

[2] The minimum and maximum switch voltage ratings may be exceeded if the switch clamping current rating is observed.



### 3.2、Recommended Operating Conditions

Characteristic	Symbol	Conditions	Min.	Typ.	Max.	Unit
supply voltage	$V_{CC}$	-	1.65	-	5.5	V
input voltage	$V_I$	-	0	-	5.5	V
switch voltage	$V_{SW}$	enable and disable mode <sup>[1]</sup>	0	-	$V_{CC}$	V
ambient temperature	$T_{amb}$	-	-40	-	+105	°C
input transition rise and fall rate	$\Delta t/\Delta V$	$V_{CC}=1.65V$ to $2.7V$ <sup>[2]</sup>	-	-	20	ns/V
		$V_{CC}=2.7V$ to $5.5V$ <sup>[2]</sup>	-	-	10	ns/V

Note:

[1] To avoid sinking GND current from terminal Z when switch current flows in terminal  $Y_n$ , the voltage drop across the bidirectional switch must not exceed 0.4V. If the switch current flows into terminal Z, no GND current will flow from terminal  $Y_n$ . In this case, there is no limit for the voltage drop across the switch.

[2] Applies to control signal levels.

### 3.3、Electrical Characteristics

#### 3.3.1、DC Characteristics 1

( $T_{amb}=-40^{\circ}C$  to  $+85^{\circ}C$ , voltages are referenced to GND (ground=0V), unless otherwise specified)

Parameter	Symbol	Conditions	Min.	Typ. <sup>[1]</sup>	Max.	Unit
HIGH-level input voltage	$V_{IH}$	$V_{CC}=1.65V$ to $1.95V$	$0.65V_{CC}$	-	-	V
		$V_{CC}=2.3V$ to $2.7V$	1.7	-	-	V
		$V_{CC}=3V$ to $3.6V$	2.0	-	-	V
		$V_{CC}=4.5V$ to $5.5V$	$0.7V_{CC}$	-	-	V
LOW-level input voltage	$V_{IL}$	$V_{CC}=1.65V$ to $1.95V$	-	-	$0.35V_{CC}$	V
		$V_{CC}=2.3V$ to $2.7V$	-	-	0.7	V
		$V_{CC}=3V$ to $3.6V$	-	-	0.8	V
		$V_{CC}=4.5V$ to $5.5V$	-	-	$0.3V_{CC}$	V
input leakage current	$I_I$	pin S; $V_I = 5.5V$ or GND; $V_{CC} = 0V$ to $5.5V$ <sup>[2]</sup>	-	$\pm 0.1$	$\pm 1$	$\mu A$
OFF-state	$I_{S(OFF)}$	$V_{CC}=5.5V$ ; see Figure 3 <sup>[2]</sup>	-	$\pm 0.1$	$\pm 0.2$	$\mu A$
ON-state	$I_{S(ON)}$	$V_{CC}=5.5V$ ; see Figure 4 <sup>[2]</sup>	-	$\pm 0.1$	$\pm 1$	$\mu A$
supply current	$I_{CC}$	$V_I=5.5V$ or GND; $V_{SW}=GND$ or $V_{CC}$ ; $V_{CC}=1.65V$ to $5.5V$ <sup>[2]</sup>	-	0.1	4	$\mu A$
additional supply current	$\Delta I_{CC}$	pin S; $V_I=V_{CC}-0.6V$ ; $V_{CC}=5.5V$ ; $V_{SW}=GND$ or $V_{CC}$ <sup>[2]</sup>	-	5	500	$\mu A$
input capacitance	$C_I$	-	-	2.5	-	pF
OFF-state capacitance	$C_{S(OFF)}$	-	-	6.0	-	pF
ON-state capacitance	$C_{S(ON)}$	-	-	18	-	pF

Note:

[1] Typical values are measured at  $T_{amb}=25^{\circ}C$ .



[2] These typical values are measured at  $V_{CC}=3.3V$

### 3.3.2、DC Characteristics 2

( $T_{amb}=-40^{\circ}C$  to  $+105^{\circ}C$ , voltages are referenced to GND (ground=0V), unless otherwise specified)

Parameter	Symbol	Conditions	Min.	Typ.	Max.	Unit
HIGH-level input voltage	$V_{IH}$	$V_{CC}=1.65V$ to $1.95V$	$0.65V_{CC}$	-	-	V
		$V_{CC}=2.3V$ to $2.7V$	1.7	-	-	V
		$V_{CC}=3V$ to $3.6V$	2.0	-	-	V
		$V_{CC}=4.5V$ to $5.5V$	$0.7V_{CC}$	-	-	V
LOW-level input voltage	$V_{IL}$	$V_{CC}=1.65V$ to $1.95V$	-	-	$0.35V_{CC}$	V
		$V_{CC}=2.3V$ to $2.7V$	-	-	0.7	V
		$V_{CC}=3V$ to $3.6V$	-	-	0.8	V
		$V_{CC}=4.5V$ to $5.5V$	-	-	$0.3V_{CC}$	V
input leakage current	$I_I$	pin S; $V_I = 5.5V$ or GND; $V_{CC} = 0V$ to $5.5V$ <sup>[1]</sup>	-	-	$\pm 1$	$\mu A$
OFF-state	$I_{S(OFF)}$	$V_{CC}=5.5V$ ; see Figure 3 <sup>[1]</sup>	-	-	$\pm 0.5$	$\mu A$
ON-state	$I_{S(ON)}$	$V_{CC}=5.5V$ ; see Figure 4 <sup>[1]</sup>	-	-	$\pm 2$	$\mu A$
supply current	$I_{CC}$	$V_I=5.5V$ or GND; $V_{SW}=GND$ or $V_{CC}$ ; $V_{CC}=1.65V$ to $5.5V$ <sup>[1]</sup>	-	-	4	$\mu A$
additional supply current	$\Delta I_{CC}$	pin S; $V_I=V_{CC}-0.6V$ ; $V_{CC}=5.5V$ ; $V_{SW}=GND$ or $V_{CC}$ <sup>[1]</sup>	-	-	500	$\mu A$



### 3.3.3、ON Resistance 1

( $T_{amb}=-40^{\circ}\text{C}$  to  $+85^{\circ}\text{C}$ , voltages are referenced to GND (ground=0V), unless otherwise specified)

Parameter	Symbol	Conditions	Min.	Typ. <sup>[1]</sup>	Max.	Unit	
ON resistance (peak)	$R_{ON(peak)}$	$V_I=GND$ to $V_{CC}$ ; see Figure 5	$I_{sw} = 4\text{ mA}; V_{CC}=1.65\text{V to }1.95\text{V}$	-	34.0	130	$\Omega$
			$I_{sw}=8\text{mA}; V_{CC}=2.3\text{V to }2.7\text{V}$	-	12.0	30	$\Omega$
			$I_{sw}=12\text{mA}; V_{CC}=2.7\text{V}$	-	10.4	25	$\Omega$
			$I_{sw}=24\text{mA}; V_{CC}=3\text{V to }3.6\text{V}$	-	7.8	20	$\Omega$
			$I_{sw}=32\text{mA}; V_{CC}=4.5\text{V to }5.5\text{V}$	-	6.2	15	$\Omega$
ON resistance (rail)	$R_{ON(rail)}$	$V_I=GND$ ; see Figure 5	$I_{sw} = 4\text{ mA}; V_{CC}=1.65\text{V to }1.95\text{V}$	-	8.2	18	$\Omega$
			$I_{sw}=8\text{mA}; V_{CC}=2.3\text{V to }2.7\text{V}$	-	7.1	16	$\Omega$
			$I_{sw}=12\text{mA}; V_{CC}=2.7\text{V}$	-	6.9	14	$\Omega$
			$I_{sw}=24\text{mA}; V_{CC}=3\text{V to }3.6\text{V}$	-	6.5	12	$\Omega$
			$I_{sw}=32\text{mA}; V_{CC}=4.5\text{V to }5.5\text{V}$	-	5.8	10	$\Omega$
		$V_I=V_{CC}$ ; see Figure 5	$I_{sw} = 4\text{ mA}; V_{CC}=1.65\text{V to }1.95\text{V}$	-	10.4	30	$\Omega$
			$I_{sw}=8\text{mA}; V_{CC}=2.3\text{V to }2.7\text{V}$	-	7.6	20	$\Omega$
			$I_{sw}=12\text{mA}; V_{CC}=2.7\text{V}$	-	7.0	18	$\Omega$
			$I_{sw}=24\text{mA}; V_{CC}=3\text{V to }3.6\text{V}$	-	6.1	15	$\Omega$
			$I_{sw}=32\text{mA}; V_{CC}=4.5\text{V to }5.5\text{V}$	-	4.9	10	$\Omega$
ON resistance (flatness)	$R_{ON(flat)}$	$V_I=GND$ to $V_{CC}$ <sup>[2]</sup>	$I_{sw} = 4\text{ mA}; V_{CC}=1.65\text{V to }1.95\text{V}$	-	26.0	-	$\Omega$
			$I_{sw}=8\text{mA}; V_{CC}=2.3\text{V to }2.7\text{V}$	-	5.0	-	$\Omega$
			$I_{sw}=12\text{mA}; V_{CC}=2.7\text{V}$	-	3.5	-	$\Omega$
			$I_{sw}=24\text{mA}; V_{CC}=3\text{V to }3.6\text{V}$	-	2.0	-	$\Omega$
			$I_{sw}=32\text{mA}; V_{CC}=4.5\text{V to }5.5\text{V}$	-	1.5	-	$\Omega$

Note:

[1] Typical values are measured at  $T_{amb}=25^{\circ}\text{C}$  and nominal  $V_{CC}$ .

[2] Flatness is defined as the difference between the maximum and minimum value of ON resistance



measured at identical  $V_{CC}$  and temperature.

### 3.3.4、ON Resistance 2

( $T_{amb}=-40^{\circ}C$  to  $+105^{\circ}C$ , voltages are referenced to GND (ground=0V), unless otherwise specified)

Parameter	Symbol	Conditions	Min.	Typ.	Max.	Unit	
ON resistance (peak)	$R_{ON(peak)}$	$V_I=GND$ to $V_{CC}$ ; see Figure 5	$I_{sw} = 4\text{ mA}; V_{CC}=1.65V$ to $1.95V$	-	-	195	$\Omega$
			$I_{sw}=8\text{ mA}; V_{CC}=2.3V$ to $2.7V$	-	-	45	$\Omega$
			$I_{sw}=12\text{ mA}; V_{CC}=2.7V$	-	-	38	$\Omega$
			$I_{sw}=24\text{ mA}; V_{CC}=3V$ to $3.6V$	-	-	30	$\Omega$
			$I_{sw}=32\text{ mA}; V_{CC}=4.5V$ to $5.5V$	-	-	23	$\Omega$
ON resistance (rail)	$R_{ON(rail)}$	$V_I=GND$ ; see Figure 5	$I_{sw} = 4\text{ mA}; V_{CC}=1.65V$ to $1.95V$	-	-	27	$\Omega$
			$I_{sw}=8\text{ mA}; V_{CC}=2.3V$ to $2.7V$	-	-	24	$\Omega$
			$I_{sw}=12\text{ mA}; V_{CC}=2.7V$	-	-	21	$\Omega$
			$I_{sw}=24\text{ mA}; V_{CC}=3V$ to $3.6V$	-	-	18	$\Omega$
			$I_{sw}=32\text{ mA}; V_{CC}=4.5V$ to $5.5V$	-	-	15	$\Omega$
		$V_I=V_{CC}$ ; see Figure 5	$I_{sw} = 4\text{ mA}; V_{CC}=1.65V$ to $1.95V$	-	-	45	$\Omega$
			$I_{sw}=8\text{ mA}; V_{CC}=2.3V$ to $2.7V$	-	-	30	$\Omega$
			$I_{sw}=12\text{ mA}; V_{CC}=2.7V$	-	-	27	$\Omega$
			$I_{sw}=24\text{ mA}; V_{CC}=3V$ to $3.6V$	-	-	23	$\Omega$
			$I_{sw}=32\text{ mA}; V_{CC}=4.5V$ to $5.5V$	-	-	15	$\Omega$





### 3.3.5、 AC Characteristics 1

( $T_{amb}=-40^{\circ}\text{C}$  to  $+85^{\circ}\text{C}$ , voltages are referenced to GND (ground=0V), unless otherwise specified)

Parameter	Symbol	Conditions	Min.	Typ. <sup>[1]</sup>	Max.	Unit	
propagation delay	$t_{pd}$	Z to Yn or Yn to Z; see Figure 12 <sup>[2][3]</sup>	$V_{CC}=1.65\text{V to }1.95\text{V}$	-	-	2	ns
			$V_{CC}=2.3\text{V to }2.7\text{V}$	-	-	1.2	ns
			$V_{CC}=2.7\text{V}$	-	-	1.0	ns
			$V_{CC}=3\text{V to }3.6\text{V}$	-	-	0.8	ns
			$V_{CC}=4.5\text{V to }5.5\text{V}$	-	-	0.6	ns
enable time	$t_{en}$	S to Yn; see Figure 13 <sup>[4]</sup>	$V_{CC}=1.65\text{V to }1.95\text{V}$	3.1	8.7	20.8	ns
			$V_{CC}=2.3\text{V to }2.7\text{V}$	2.2	5.3	11.5	ns
			$V_{CC}=2.7\text{V}$	2.1	4.9	9.3	ns
			$V_{CC}=3\text{V to }3.6\text{V}$	1.8	4.0	7.6	ns
			$V_{CC}=4.5\text{V to }5.5\text{V}$	1.5	3.0	5.7	ns
disable time	$t_{dis}$	S to Yn; see Figure 13 <sup>[5]</sup>	$V_{CC}=1.65\text{V to }1.95\text{V}$	3.0	6.0	11.4	ns
			$V_{CC}=2.3\text{V to }2.7\text{V}$	2.1	4.4	7.3	ns
			$V_{CC}=2.7\text{V}$	2.1	4.2	6.3	ns
			$V_{CC}=3\text{V to }3.6\text{V}$	1.7	3.6	5.3	ns
			$V_{CC}=4.5\text{V to }5.5\text{V}$	1.3	2.9	3.8	ns
break-before emake time	$t_{b-m}$	see Figure 14 <sup>[6]</sup>	$V_{CC}=1.65\text{V to }1.95\text{V}$	0.5	-	-	ns
			$V_{CC}=2.3\text{V to }2.7\text{V}$	0.5	-	-	ns
			$V_{CC}=2.7\text{V}$	0.5	-	-	ns
			$V_{CC}=3\text{V to }3.6\text{V}$	0.5	-	-	ns
			$V_{CC}=4.5\text{V to }5.5\text{V}$	0.5	-	-	ns

Note:

[1] Typical values are measured at  $T_{amb}=25^{\circ}\text{C}$  and nominal  $V_{CC}$ .

[2]  $t_{pd}$  is the same as  $t_{PLH}$  and  $t_{PHL}$ .

[3] Propagation delay is the calculated RC time constant of the typical ON resistance of the switch and the specified capacitance when driven by an ideal voltage source (zero output impedance).

[4]  $t_{en}$  is the same as  $t_{PZH}$  and  $t_{PZL}$ .

[5]  $t_{dis}$  is the same as  $t_{PLZ}$  and  $t_{PHZ}$ .

[6] Break-before-make specified by design.



## 3.3.6、 AC Characteristics 2

( $T_{amb}=-40^{\circ}\text{C}$  to  $+105^{\circ}\text{C}$ , voltages are referenced to GND (ground=0V), unless otherwise specified)

Parameter	Symbol	Conditions	Min.	Typ. <sup>[1]</sup>	Max.	Unit	
propagation delay	$t_{pd}$	Z to Yn or Yn to Z; see Figure 12 <sup>[2][3]</sup>	$V_{CC}=1.65\text{V to }1.95\text{V}$	-	-	3.0	ns
			$V_{CC}=2.3\text{V to }2.7\text{V}$	-	-	2.0	ns
			$V_{CC}=2.7\text{V}$	-	-	1.5	ns
			$V_{CC}=3\text{V to }3.6\text{V}$	-	-	1.5	ns
			$V_{CC}=4.5\text{V to }5.5\text{V}$	-	-	1.0	ns
enable time	$t_{en}$	S to Yn; see Figure 13 <sup>[4]</sup>	$V_{CC}=1.65\text{V to }1.95\text{V}$	3.1	-	22.0	ns
			$V_{CC}=2.3\text{V to }2.7\text{V}$	2.2	-	12.5	ns
			$V_{CC}=2.7\text{V}$	2.1	-	10.5	ns
			$V_{CC}=3\text{V to }3.6\text{V}$	1.8	-	9.0	ns
			$V_{CC}=4.5\text{V to }5.5\text{V}$	1.5	-	6.1	ns
disable time	$t_{dis}$	S to Yn; see Figure 13 <sup>[5]</sup>	$V_{CC}=1.65\text{V to }1.95\text{V}$	3.0	-	11.7	ns
			$V_{CC}=2.3\text{V to }2.7\text{V}$	2.1	-	7.6	ns
			$V_{CC}=2.7\text{V}$	2.1	-	6.6	ns
			$V_{CC}=3\text{V to }3.6\text{V}$	1.7	-	5.9	ns
			$V_{CC}=4.5\text{V to }5.5\text{V}$	1.3	-	4.3	ns
break-before make time	$t_{b-m}$	see Figure 14 <sup>[6]</sup>	$V_{CC}=1.65\text{V to }1.95\text{V}$	0.5	-	-	ns
			$V_{CC}=2.3\text{V to }2.7\text{V}$	0.5	-	-	ns
			$V_{CC}=2.7\text{V}$	0.5	-	-	ns
			$V_{CC}=3\text{V to }3.6\text{V}$	0.5	-	-	ns
			$V_{CC}=4.5\text{V to }5.5\text{V}$	0.5	-	-	ns

Note:

[1] Typical values are measured at  $T_{amb}=25^{\circ}\text{C}$  and nominal  $V_{CC}$ .

[2]  $t_{pd}$  is the same as  $t_{PLH}$  and  $t_{PHL}$ .

[3] Propagation delay is the calculated RC time constant of the typical ON resistance of the switch and the specified capacitance when driven by an ideal voltage source (zero output impedance).

[4]  $t_{en}$  is the same as  $t_{PZH}$  and  $t_{PZL}$ .

[5]  $t_{dis}$  is the same as  $t_{PLZ}$  and  $t_{PHZ}$ .

[6] Break-before-make specified by design.



### 3.3.7. Additional AC Characteristics

( $T_{amb}=25^{\circ}\text{C}$ , voltages are referenced to GND (ground=0V), unless otherwise specified)

Parameter	Symbol	Conditions	Min.	Typ.	Max.	Unit	
total harmonic distortion	THD	$f_i=600\text{Hz to }20\text{kHz};$ $R_L=600\Omega;$ $C_L=50\text{pF}; V_I=0.5\text{V(p-p)};$ see Figure 16	$V_{CC}=1.65\text{V}$	-	0.260	-	%
			$V_{CC}=2.3\text{V}$	-	0.078	-	%
			$V_{CC}=3.0\text{V}$	-	0.078	-	%
			$V_{CC}=4.5\text{V}$	-	0.078	-	%
-3 dB frequency response	$f_{(-3\text{dB})}$	$R_L=50\Omega;$ see Figure 17	$V_{CC}=1.65\text{V}$	-	200	-	MHz
			$V_{CC}=2.3\text{V}$	-	300	-	MHz
			$V_{CC}=3.0\text{V}$	-	300	-	MHz
			$V_{CC}=4.5\text{V}$	-	300	-	MHz
isolation (OFF-state)	$\alpha_{iso}$	$R_L=50\Omega; C_L=5\text{pF};$ $f_i=10\text{MHz};$ see Figure 18	$V_{CC}=1.65\text{V}$	-	-42	-	dB
			$V_{CC}=2.3\text{V}$	-	-42	-	dB
			$V_{CC}=3.0\text{V}$	-	-40	-	dB
			$V_{CC}=4.5\text{V}$	-	-40	-	dB
charge injection	$Q_{inj}$	$C_L=0.1\text{nF}; V_{gen}=0\text{V};$ $R_{gen}=0\Omega;$ $f_i=1\text{MHz}; R_L=1\text{M}\Omega;$ see Figure 19	$V_{CC}=1.8\text{V}$	-	3.3	-	pC
			$V_{CC}=2.5\text{V}$	-	4.1	-	pC
			$V_{CC}=3.3\text{V}$	-	5.0	-	pC
			$V_{CC}=4.5\text{V}$	-	6.4	-	pC
			$V_{CC}=5.5\text{V}$	-	7.5	-	pC

## 4. Testing Circuit

### 4.1. DC Testing Circuit

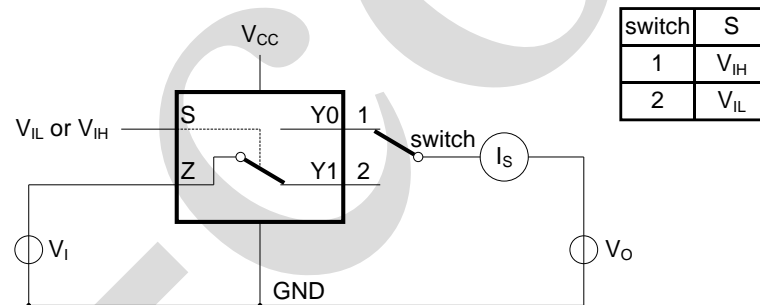

$V_I=V_{CC}$  or  $GND$  and  $V_o=GND$  or  $V_{CC}$ .

Figure 3. Test circuit for measuring OFF-state leakage current

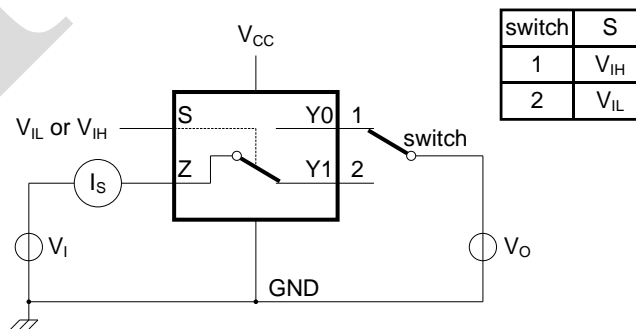

$V_I=V_{CC}$  or  $GND$  and  $V_o=open\ circuit$ .

Figure 4. Test circuit for measuring ON-state leakage current



## 4.2、ON Resistance Test Circuit And Graphs

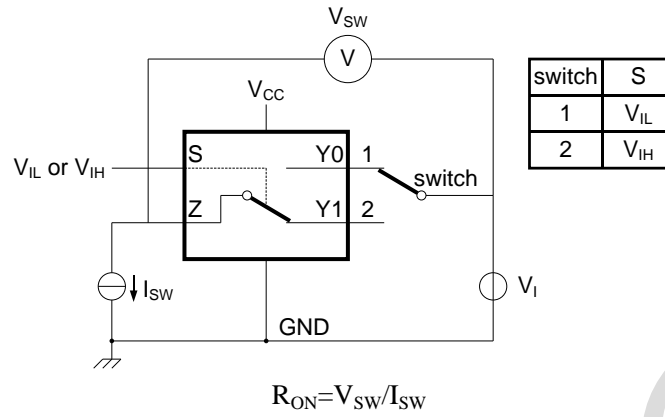
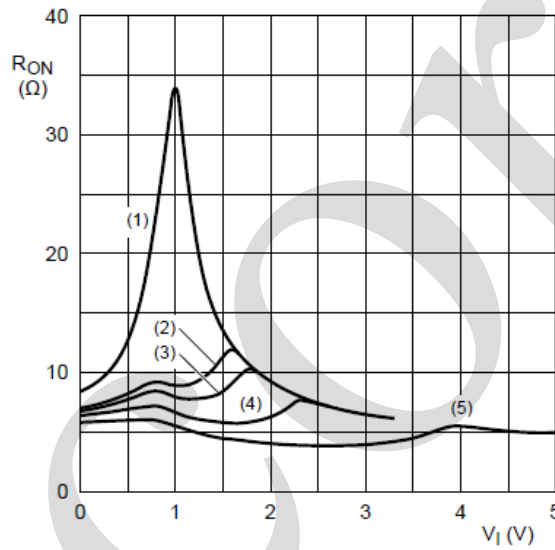
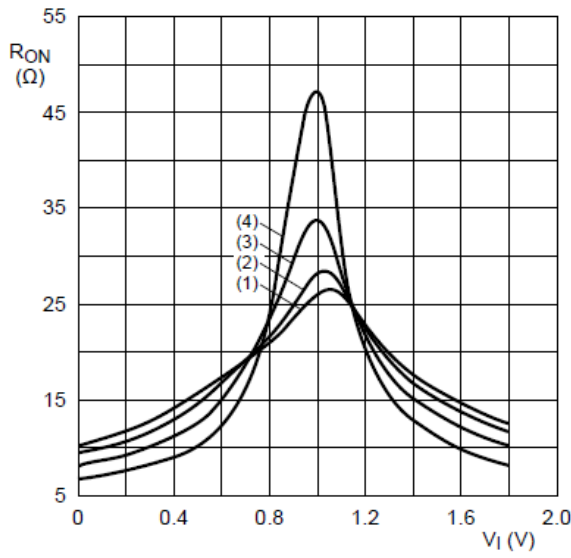

Figure 5. Test circuit for measuring ON resistance



- (1) V<sub>CC</sub>=1.8V.
- (2) V<sub>CC</sub>=2.5V.
- (3) V<sub>CC</sub>=2.7V.
- (4) V<sub>CC</sub>=3.3V.
- (5) V<sub>CC</sub>=5.0V.

Figure 6. Typical ON resistance as a function of input voltage; T<sub>amb</sub>=25°C



- (1)  $T_{amb}=105^{\circ}\text{C}$ .
- (2)  $T_{amb}=85^{\circ}\text{C}$ .
- (3)  $T_{amb}=25^{\circ}\text{C}$ .
- (4)  $T_{amb}=-40^{\circ}\text{C}$ .

Figure 7. ON resistance as a function of input voltage;  $V_{CC}=1.8\text{V}$

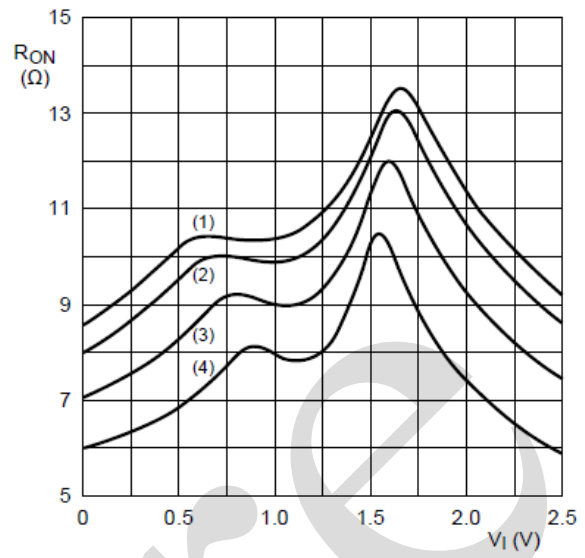

- (1)  $T_{amb}=105^{\circ}\text{C}$ .
- (2)  $T_{amb}=85^{\circ}\text{C}$ .
- (3)  $T_{amb}=25^{\circ}\text{C}$ .
- (4)  $T_{amb}=-40^{\circ}\text{C}$ .

Figure 8. ON resistance as a function of input voltage;  $V_{CC}=2.5\text{V}$

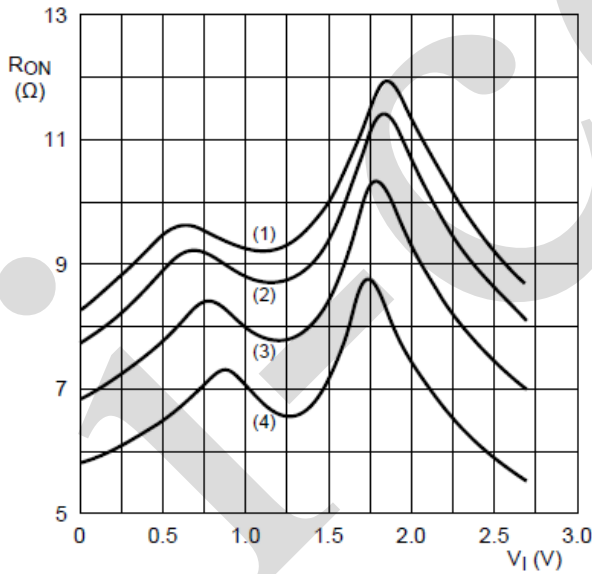

- (1)  $T_{amb}=105^{\circ}\text{C}$ .
- (2)  $T_{amb}=85^{\circ}\text{C}$ .
- (3)  $T_{amb}=25^{\circ}\text{C}$ .
- (4)  $T_{amb}=-40^{\circ}\text{C}$ .

Figure 9. ON resistance as a function of input voltage;  $V_{CC}=2.7\text{V}$

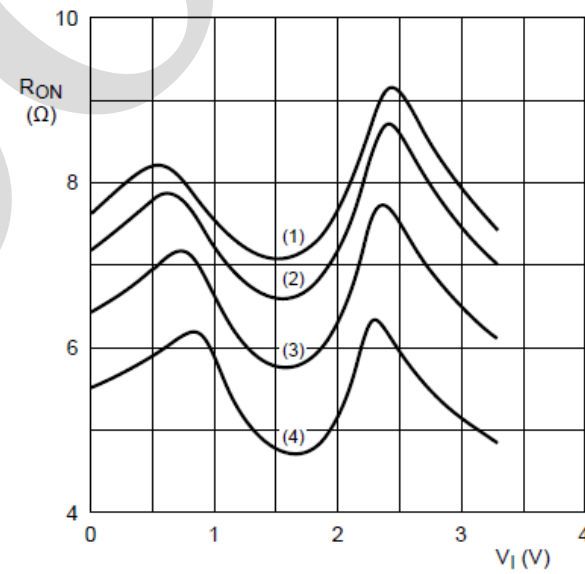

- (1)  $T_{amb}=105^{\circ}\text{C}$ .
- (2)  $T_{amb}=85^{\circ}\text{C}$ .
- (3)  $T_{amb}=25^{\circ}\text{C}$ .
- (4)  $T_{amb}=-40^{\circ}\text{C}$ .

Figure 10. ON resistance as a function of input voltage;  $V_{CC}=3.3\text{V}$

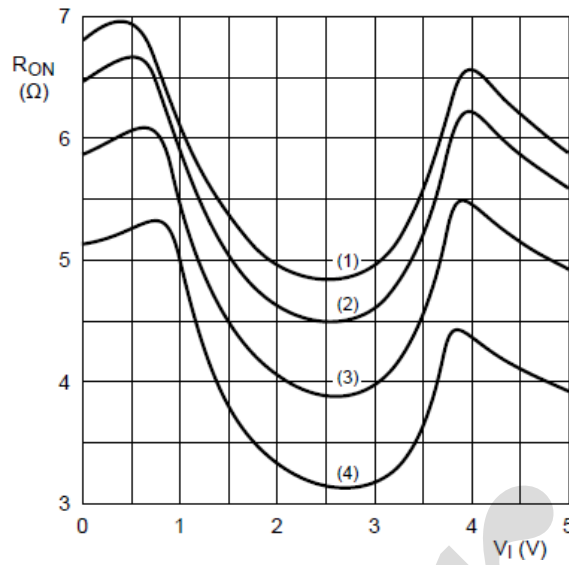

- (1)  $T_{amb}=105^{\circ}\text{C}$ .
- (2)  $T_{amb}=85^{\circ}\text{C}$ .
- (3)  $T_{amb}=25^{\circ}\text{C}$ .
- (4)  $T_{amb}=-40^{\circ}\text{C}$ .

Figure 11. ON resistance as a function of input voltage;  $V_{CC}=5.0\text{V}$

### 4.3. AC Testing Waveforms

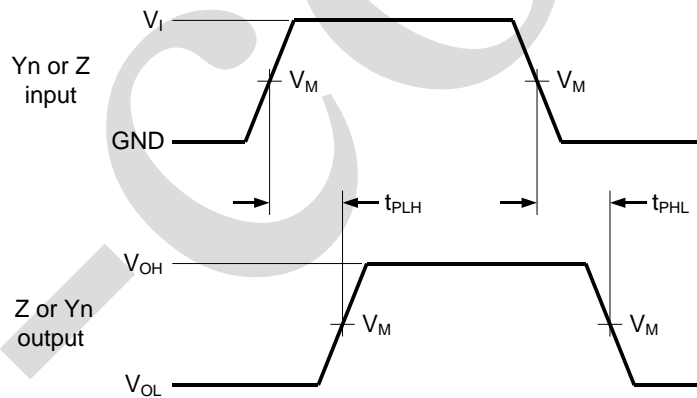

Logic levels:  $V_{OL}$  and  $V_{OH}$  are typical output voltage levels that occur with the output load.

Figure 12. Input (Yn or Z) to output (Z or Yn) propagation delays

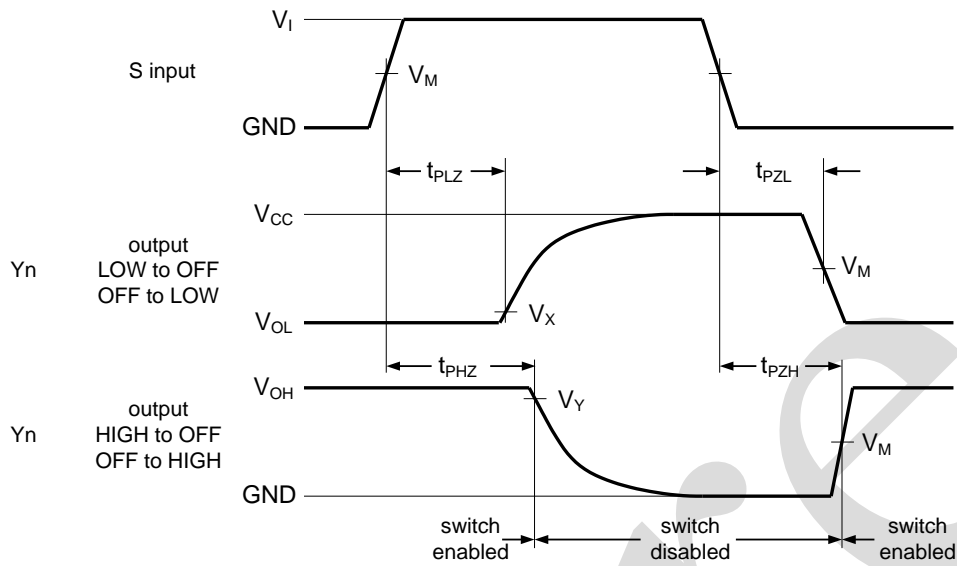

Logic levels:  $V_{OL}$  and  $V_{OH}$  are typical output voltage levels that occur with the output load.

Figure 13. Enable and disable times

#### 4.4. Measurement Points

Supply voltage	Input	Output		
$V_{CC}$	$V_M$	$V_M$	$V_X$	$V_Y$
1.65V to 5.5V	$0.5 \times V_{CC}$	$0.5 \times V_{CC}$	$V_{OL} + 0.3V$	$V_{OH} - 0.3V$

#### 4.5. AC Testing Circuit

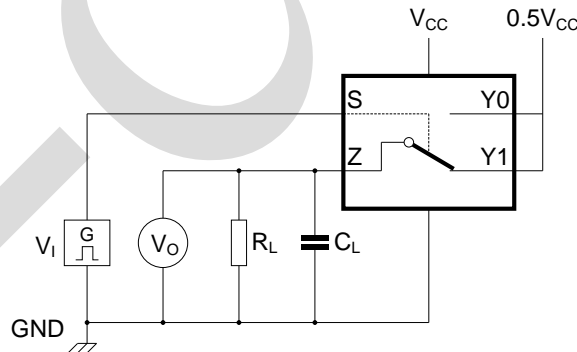

a. Test circuit

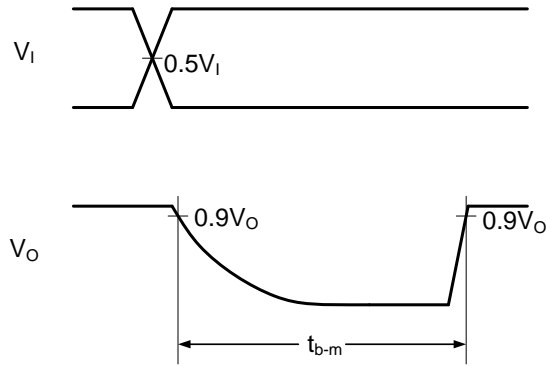

b. Input and output measurement points

Figure 14. Test circuit for measuring break-before-make timing

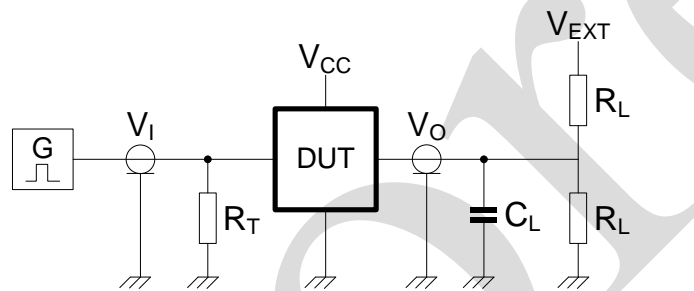

Definitions test circuit:

 $R_T$ =Termination resistance should be equal to output impedance  $Z_o$  of the pulse generator. $C_L$ =Load capacitance including jig and probe capacitance. $R_L$ =Load resistance. $V_{EXT}$ =External voltage for measuring switching times.

Figure 15. Test circuit for measuring switching times

## 4.6. Test Data

Supply voltage	Input		Load		$V_{EXT}$		
	$V_I$	$t_r, t_f$	$C_L$	$R_L$	$t_{PLH}, t_{PHL}$	$t_{PZH}, t_{PHZ}$	$t_{PZL}, t_{PLZ}$
$V_{CC}$ 1.65V to 1.95V	$V_{CC}$	$\leq 2.0ns$	50pF	500 $\Omega$	open	GND	$2 \times V_{CC}$
2.3V to 2.7V	$V_{CC}$	$\leq 2.0ns$	50pF	500 $\Omega$	open	GND	$2 \times V_{CC}$
2.7V	$V_{CC}$	$\leq 2.5ns$	50pF	500 $\Omega$	open	GND	$2 \times V_{CC}$
3V to 3.6V	$V_{CC}$	$\leq 2.5ns$	50pF	500 $\Omega$	open	GND	$2 \times V_{CC}$
4.5V to 5.5V	$V_{CC}$	$\leq 2.5ns$	50pF	500 $\Omega$	open	GND	$2 \times V_{CC}$





## 4.7. Additional AC Testing Circuit

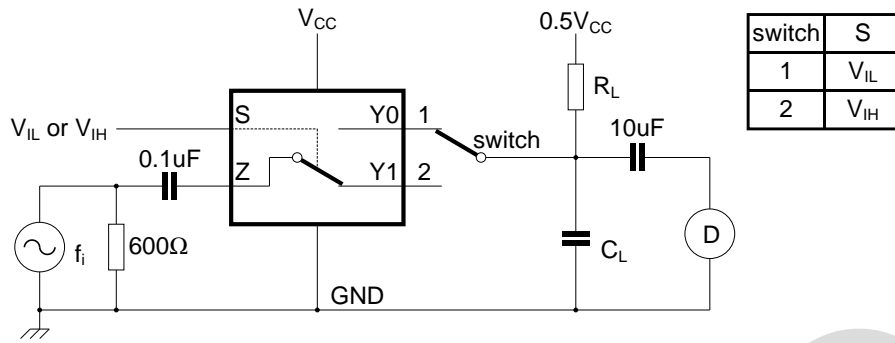
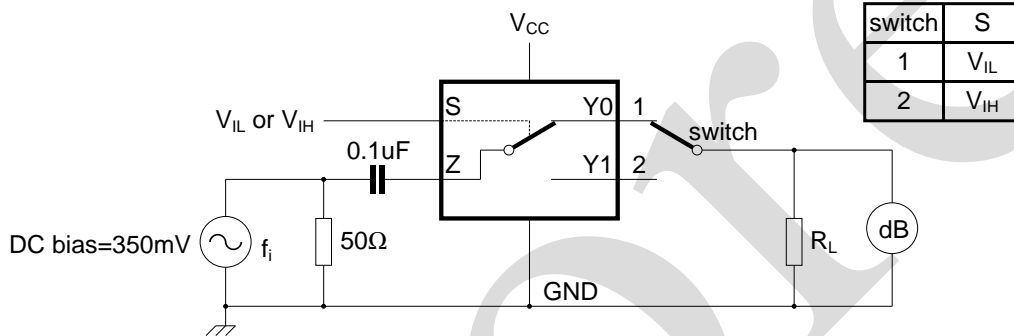
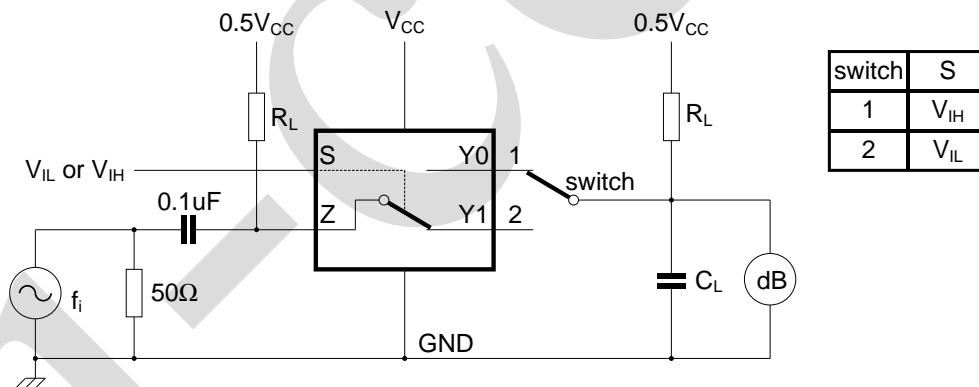

Figure 16. Test circuit for measuring total harmonic distortion



Adjust  $f_i$  voltage to obtain 0dBm level at output. Increase  $f_i$  frequency until dB meter reads -3dB.

Figure 17. Test circuit for measuring the frequency response when switch is in ON-state



Adjust  $f_i$  voltage to obtain 0dBm level at input.

Figure 18. Test circuit for measuring isolation (OFF-state)

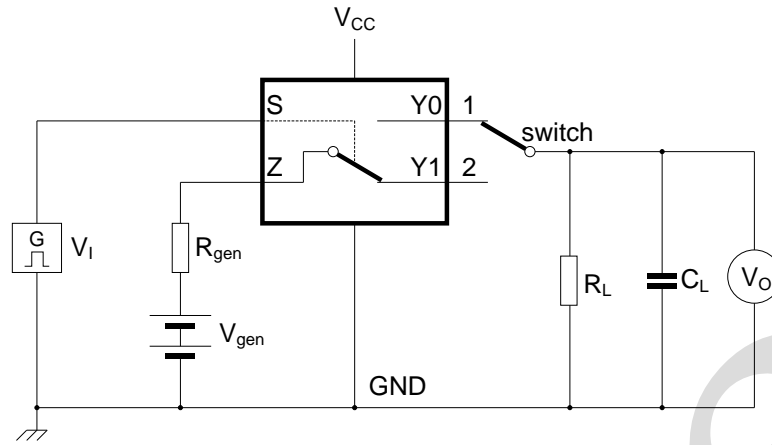

a. Test circuit

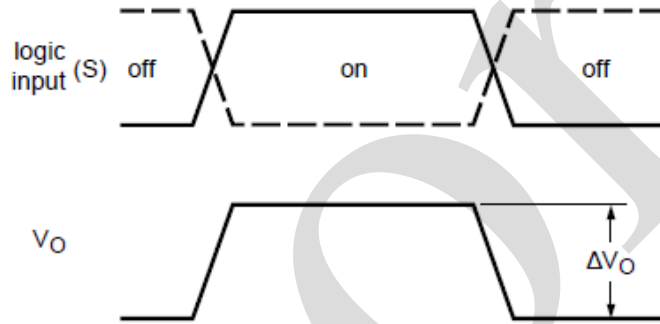

b. Input and output pulse definitions

$$Q_{inj} = \Delta V_o \times C_L.$$

$\Delta V_o$  = output voltage variation.

$R_{gen}$  = generator resistance.

$V_{gen}$  = generator voltage.

Figure 19. Test circuit for measuring charge injection



## 5、Package Information

### 5.1、SOT23-6

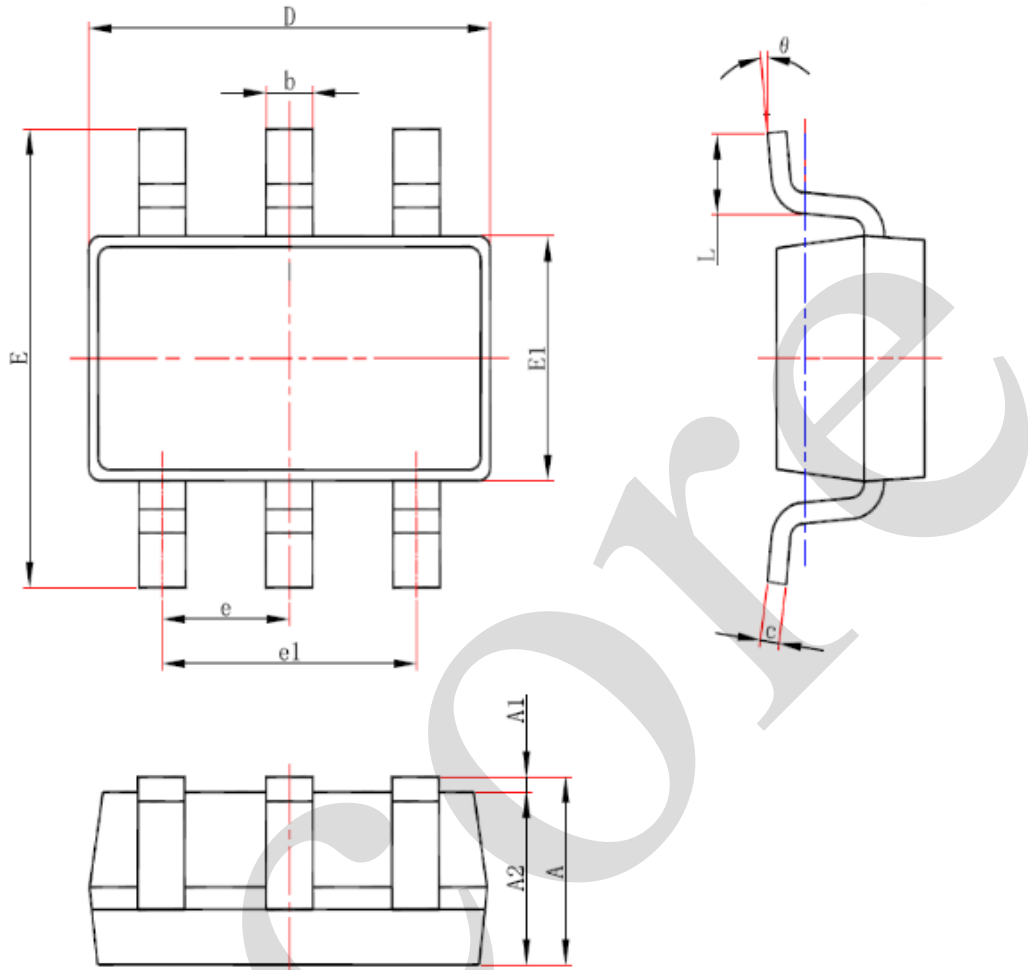

Symbol	Dimensions (mm)	
	Min.	Max.
A	-	1.25
A1	0.00	0.12
A2	1.00	1.20
b	0.30	0.50
c	0.10	0.20
D	2.82	3.02
E	2.60	3.00
E1	1.50	1.70
e	0.95	
e1	1.80	2.00
L	0.30	0.60
$\theta$	0°	8°



## 5.2、SOT363

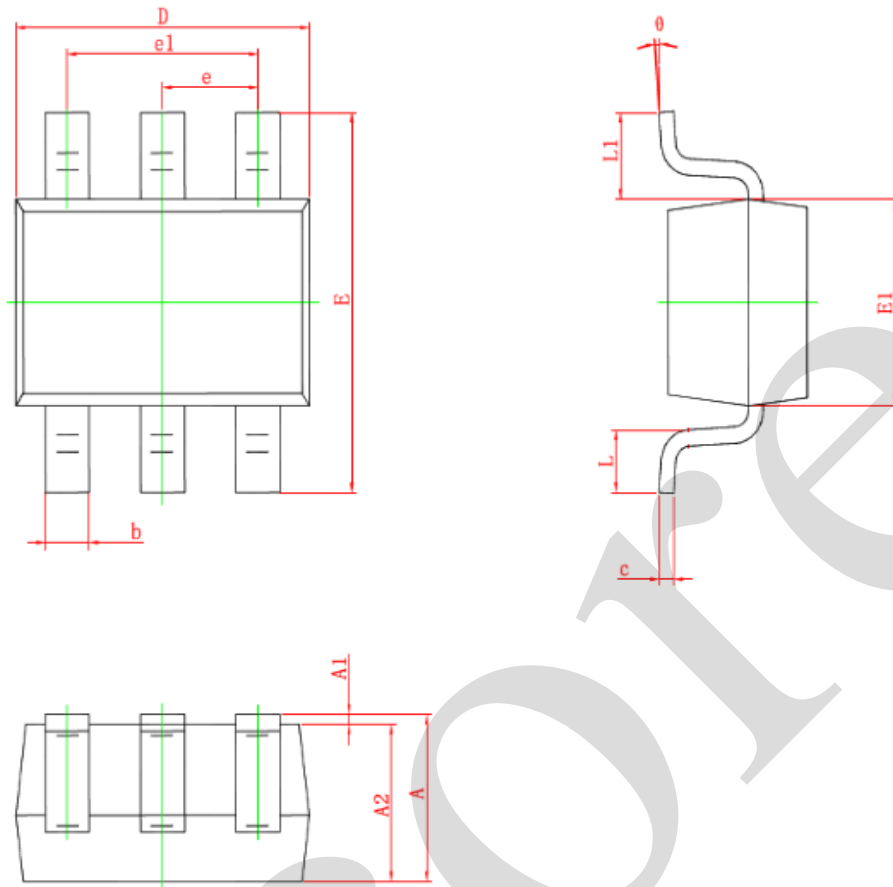

Symbol	Dimensions (mm)	
	Min.	Max.
A	0.90	1.10
A1	0.00	0.10
A2	0.90	1.00
b	0.15	0.35
c	0.11	0.175
D	2.00	2.20
E	2.15	2.45
E1	1.15	1.35
e	0.65	
e1	1.20	1.40
L	0.26	0.46
L1	0.525	
$\theta$	0°	8°



## 5.3、XSON6

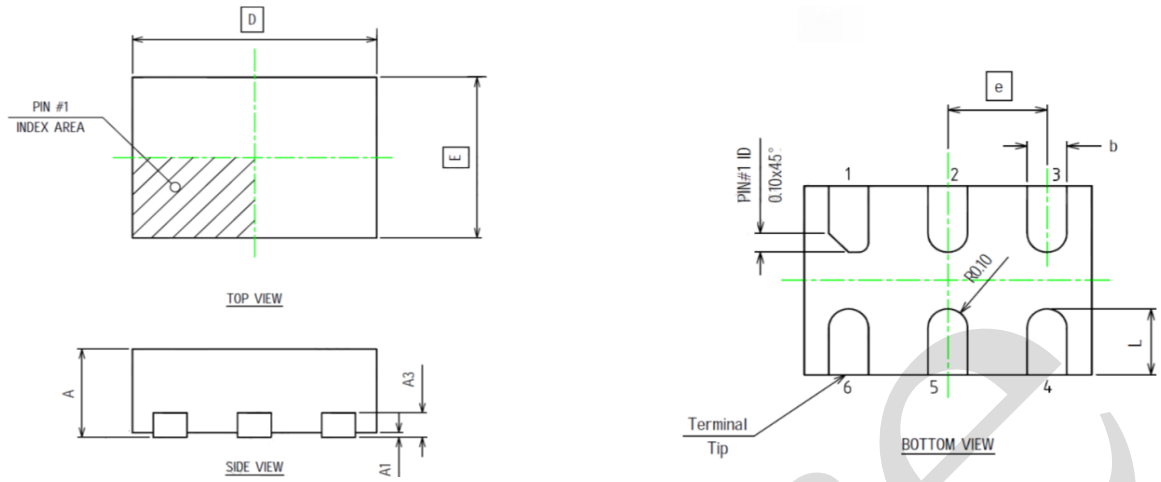

Symbol	Dimensions (mm)	
	Min.	Max.
A	0.51	0.60
A1	0.00	0.05
A3	0.15	
b	0.15	0.25
D	1.45	
E	1.00	
e	0.50	
L	0.25	0.45



## 6、 Statements And Notes

### 6.1、 The name and content of Hazardous substances or Elements in the product

Part name	Hazardous substances or Elements									
	Lead and lead compounds	Mercury and mercury compounds	Cadmium and cadmium compounds	Hexavalent chromium compounds	Polybrominated biphenyls	Polybrominated biphenyl ethers	Dibutyl phthalate	Butylbenzyl phthalate	Di-2-ethylhexyl phthalate	Diisobutyl phthalate
Lead frame	○	○	○	○	○	○	○	○	○	○
Plastic resin	○	○	○	○	○	○	○	○	○	○
Chip	○	○	○	○	○	○	○	○	○	○
The lead	○	○	○	○	○	○	○	○	○	○
Plastic sheet installed	○	○	○	○	○	○	○	○	○	○
explanation	○: Indicates that the content of hazardous substances or elements in the detection limit of the following the SJ/T11363-2006 standard. ×: Indicates that the content of hazardous substances or elements exceeding the SJ/T11363-2006 Standard limit requirements.									

### 6.2、 Notes

Recommended carefully reading this information before the use of this product;

The information in this document are subject to change without notice;

This information is using to the reference only, the company is not responsible for any loss;

The company is not responsible for the any infringement of the third party patents or other rights of the responsibility.