

REV.	DESCRIPTION	APPD	DATE

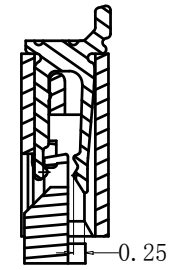

NOTES:  
 1.MATERIAL:  
 HOUSING: HIGH TEMPERATURE THERMOPLASTIC UL94V\_0,COLOR:BLACK.  
 CONTACT: COPPER ALLOYS.  
 2.PLATING:  
 UNDERPLATE: NICKEL.  
 CONTACT AREA: TIN OVER NICKEL.  
 3.MULTIMEDIA CARD COMPATIBLE

PIN NO.	DIM. A	DIM. B	DIM. C
28	18.40	13.50	14.57
29	18.90	14.00	15.07
30	19.40	14.50	15.57
31	19.90	15.00	16.07
32	20.40	15.50	16.57
33	20.90	16.00	17.07
34	21.40	16.50	17.57
35	21.90	17.00	18.07
36	22.40	17.50	18.57
37	22.90	18.00	19.07
38	23.40	18.50	19.57
39	23.90	19.00	20.07
40	24.40	19.50	20.57
41	24.90	20.00	21.07
42	25.40	20.50	21.57
43	25.90	21.00	22.07
44	26.40	21.50	22.57
45	26.90	22.00	23.07
46	27.40	22.50	23.57
47	27.90	23.00	24.07
48	28.40	23.50	24.57
49	28.90	24.00	25.07
50	29.40	24.50	25.57
51	29.90	25.00	26.07
52	30.40	25.50	26.57
53	30.90	26.00	27.07
54	31.40	26.50	27.57
55	31.90	27.00	28.07
56	32.40	27.50	28.57
57	32.90	28.00	29.07
58	33.40	28.50	29.57
59	33.90	29.00	30.07
60	34.40	29.50	30.57

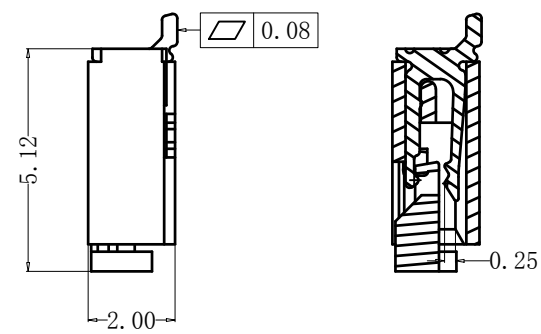
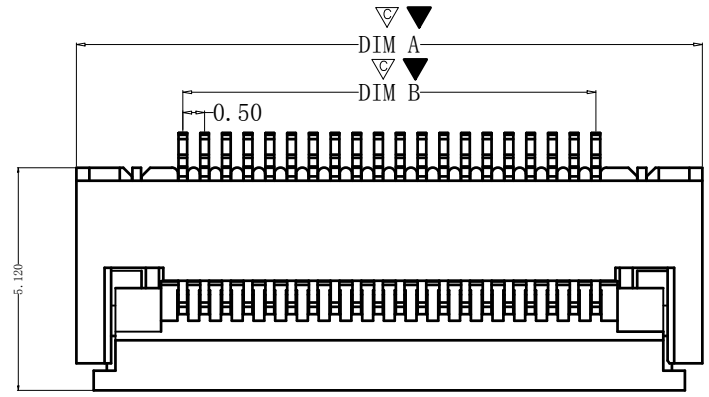
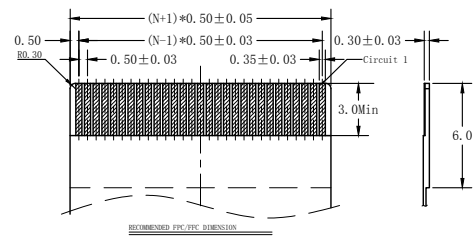
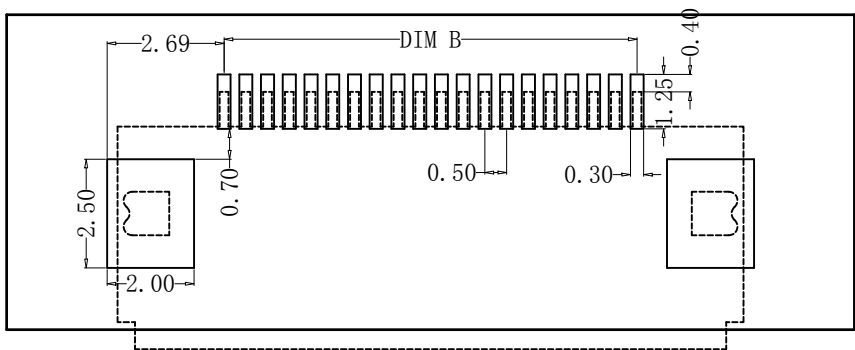
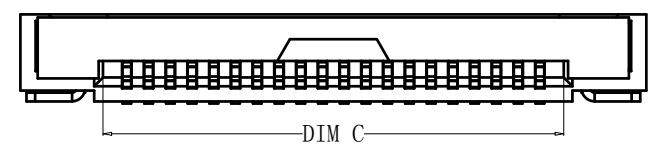

PART NO:		MATERIAL:			
LOT NO:		FINSH:			
UNIT: MM	SIZE: A4	COLOR:		TITLE: 0.5mm P数: 40 翻盖式 下接	
TOLERANCES: X.X=±0.35 X.XX=±0.25 X.XXX=±0.15		GENERAL ANGLE: X.X=±3.0° X.XX=±2.0°		DR:	DWG NO: ZX-FPC-FWX0.5PH240
				CHK:	REV: C/O
				APP:	SCALE: 1:1 SHEET: 1 OF 1