

REV	LTR	DESCRIPTION	DATE	APPROVED
A0		依新料号编码原则发行图面	23/05/21	Lin R

备注:
 1.材质:
 1.1胶芯: LCP+30%G.F
 1.2端子: C1814, T=0.12mm; 镀半金锡
 1.3外壳: 不锈钢, T=0.30mm; 表面镀镍
 1.4卡片: 不锈钢, T=0.15mm;
 2.主要特性:
 2.1额定电流: 3A FOR VBUS;
 1.25A FOR GND;
 0.25A FOR OTHER.
 2.2接触阻抗: 40mΩ MAX
 2.3绝缘阻抗: 100MΩ MIN
 2.4耐压测试: 100V AC
 2.5沾锡性: 温度245±5℃, 时间5±0.5s
 2.6整体插入力: 5~20N
 整体拔出力: 8~20N
 耐久后拔出力: 6~20N
 2.7使用寿命: 10000次
 2.8工作温度: -25℃~+80℃

PIN ASSIGNMENT:

Pin No.	Signal Name	Pin No.	Signal Name
A1	CND	B12	CND
A2		B11	
A3		B10	
A4	VBUS	B9	VBUS
A5	CC1	B8	SBU2
A6	D+	B7	D-
A7	D-	B6	D+
A8	SBU1	B5	CC2
A9	VBUS	B4	VBUS
A10		B3	
A11		B2	
A12	CND	B1	CND

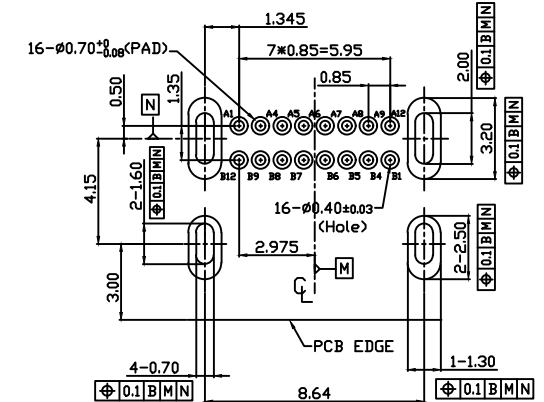
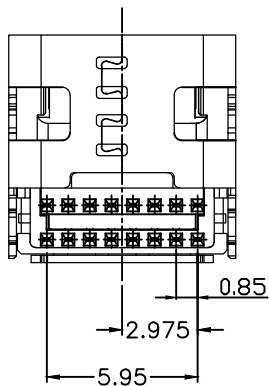
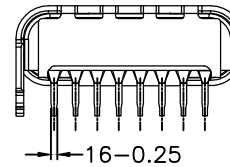
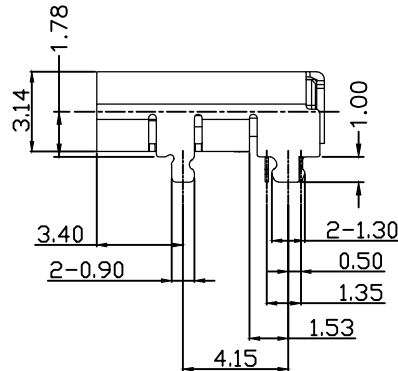
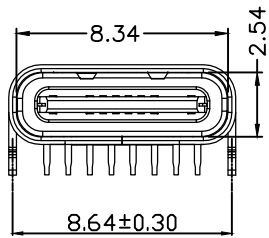
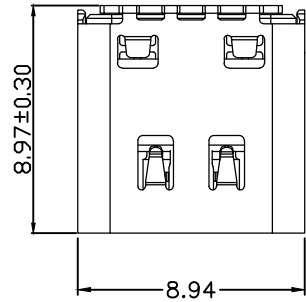

RECOMMENDED P.C.B LAYOUT

GENERAL TOLERANCE:±0.05
 PCB TOP SURFACE

序号	料号	材质	规格
1	ZX-TYPEC-WCM1648	1.胶芯: 黑胶LCP; 2.端子: C1814;	1. 端子: 半金锡6U"; 2. 外壳: 哑镍
2		3. 外壳: 不锈钢304;	1. 端子: 半金锡G/F; 2. 外壳: 哑镍
3		4. 卡片: 不锈钢301.	

TOLERANCES .X ±0.30 .XX ±0.20 .XXX ±0.10 ANGLES ±1.00°		 兆星精密电子 (深圳) 有限公司 TITLE: Type-C 母座 弯插			
 APPD.: Lin R CHECK:	DRAWING NO.: ZX-TYPEC-WCM1648				
DRAWN:	REV.: A/0	SIZE: A4	UNIT: M M	SCALE: 1 : 1	SHEET: 1 / 1