

CPS121-1500



Consensic

Data Sheet

Digital Barometer

Rev1.0
February 2022
DAT-0034

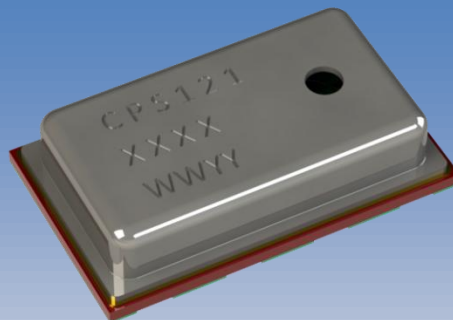

Overview

The CPS121-1500 system-in-a-package (SIP) solution comprises of a resistive bridge type pressure sensor and a 24-bit ADC for high resolution and accurate pressure measurements. The fully calibrated pressure and temperature compensated digital output makes the CPS121-1500 solution simple to use. The CPS121-1500 includes internal calibration logic that provides accurate pressure and temperature measurements to the application via the I²C interface. There is no need to separately download internal calibration coefficients and have the host microcontroller perform complicated compensation calculations.

Applications

- Smartphones
- Wearables
- Altimeters
- Portable and Stationary Barometers
- Weather Stations
- GPS Applications
- Hard Disk Drives (HDD)
- Industrial Equipment
- Air Control Systems
- Vacuum Systems

Benefits

- Low Power Consumption
- Excellent for Battery Applications
- External Clock not Required
- High Resistance to Sensing Media

Features

- Factory Calibrated Pressure and Temperature Sensor
- Supply Voltage: 2V to 5.5V (3V @ typical)
- Average Current Consumption: <5uA (One Measurement)
- Sleep State Current Consumption: <200nA (25°C)
- Operating Temperature Range: -40°C to +85°C
- Pressure Absolute Accuracy: ±4kPa (±40.0mbar) @ 0°C to 50°C, 50kPa to 1500kPa
- Temperature Accuracy: ±1.0°C

Interfaces

- I²C (up to 400kHz)

Physical Characteristics

- Small Form Factor, 3 x 5 x 1.2mm (w x l x h)
- LGA Package, 8 Lead
- Top Side Sensing Port



CPS121-1500 BLOCK DIAGRAM

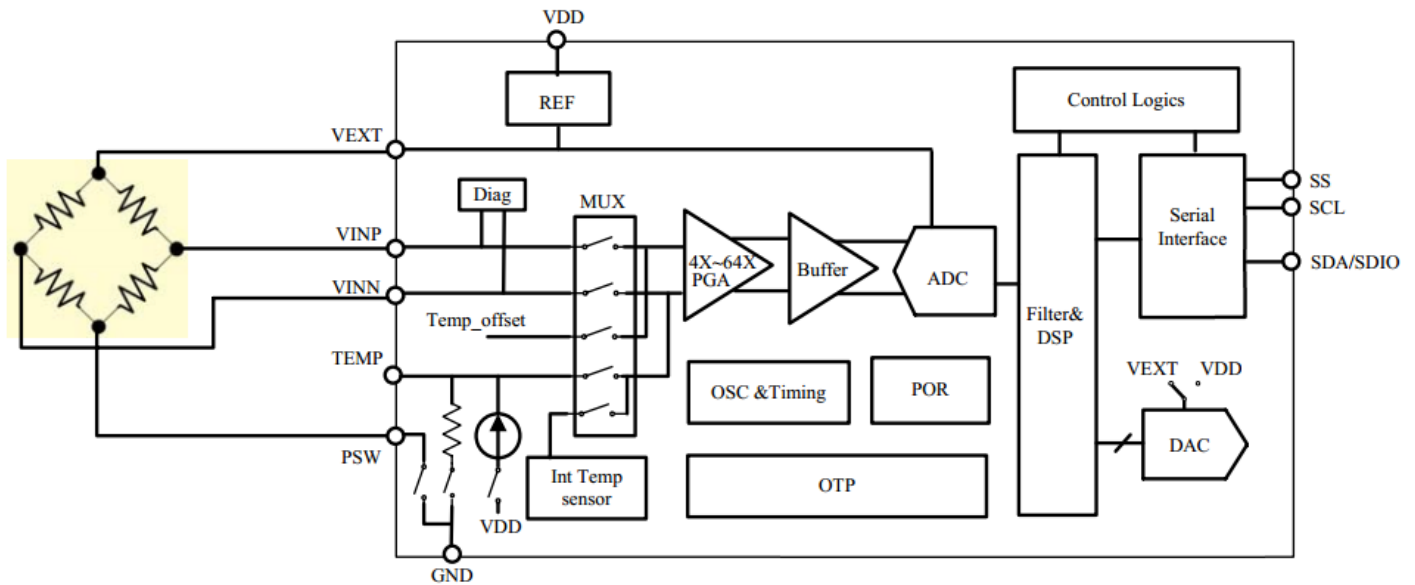

TABLE1: ORDERING INFORMATION

PART NUMBER	OUTPUT MODE	OPERATION MODE	PACKAGE
CPS121-1500	1°C	Sleep	8-Lead LGA
SALES and CONTACT INFORMATION sales@consensic.com			www.consensic.com
United States Consensic, Inc. 1900 Powell Street, Suite 600 Emeryville California, 94608, USA Ph: +1 650.288.4750	China Wuxi Consensic Electronics Co., Ltd. No.86, Dicui Road, B5 Building, Fourth Floor, Room 401, Wuxi, Jiangsu Province, 214072 Ph: +86 510.85122279 Fax: +86 510.85122259	无锡康森斯克电子科技有限公司 无锡市滨湖区滴翠路 86 号太湖智谷科技园 北门 B5 栋 4 楼 401 室 邮编: 214072 电话: +86 510.85122279 传真: +86 510.85122259	

CONTENTS

1	OPERATING CHARACTERISTICS	6
1.1	ABSOLUTE RATINGS.....	6
1.2	OPERATING CONDITIONS	6
1.3	ELECTRICAL PARAMETERS	7
2	OPERATION MODES	7
3	OUTPUT MODES.....	7
3.1	I ² C	7
3.2	I ² C COMMANDS.....	7
3.3	I ² C GET DATA (GD).....	8
3.4	I ² C MEASUREMENT REQUEST (MR).....	10
4	CALCULATING OUTPUT	11
4.1	PRESSURE OUTPUT.....	11
4.2	TEMPERATURE OUTPUT	11
5	PACKAGE AND ASSEMBLY	12
5.1	PIN ASSEMBLY AND MECHANICAL DRAWING	12
5.2	SOLDERING CONDITIONS	13
6	APPLICATION DIAGRAM	14
7	DOCUMENT HISTORY	14

8	DISCLAIMER.....	15
---	-----------------	----

LIST OF TABLES

TABLE 1:	ORDERING INFORMATION	3
TABLE 2:	I ² C COMMANDS.....	8

LIST OF FIGURES

FIGURE 1:	SLAVE ADDRESS FOLLOWED BY THREE PRESSURE AND TWO TEMPERATURE BYTES	9
FIGURE 2:	7-BIT SLAVE ADDRESS FOLLOWED BY THREE PRESSURE BYTES	9
FIGURE 3:	I ² C MEASUREMENT REQUEST COMMAND	10

1 OPERATING CHARACTERISTICS

1.1 ABSOLUTE RATINGS

PARAMETER	SYMBOL	CONDITIONS	MIN	TYP	MAX	UNITS
Over Pressure					2X FS	kPa (bar)
Supply Voltage (with respect to GND)	V_{DD}		-0.3		6.5	V
Voltages at Analog and Digital I/O Pins	V_{A_IO} V_{D_IO}		-0.3		$V_{DD} + 0.3$	V
Storage Temperature	T_{STOR}		-60		150	°C

1.2 OPERATING CONDITIONS

PARAMETER	SYMBOL	CONDITIONS	MIN	TYP	MAX	UNITS
PRESSURE SENSOR						
Range			50 (500)		1500 (15000)	kPa (mbar)
Resolution ¹				0.17		Pa
Noise in Pressure		Full Bandwidth, Normal Mode Altitude Based on Relative Pressure		1 10		Pa cm
Accuracy		50 to 1500kPa (-20°C to 0°C)	-4.5 (-45)	±4 (±40)	+4.5 (+45)	kPa (mbar)
		50 to 1500kPa (0°C to 65°C)	-3.5 (-35)	±3 (±30)	+3.5 (+35)	kPa (mbar)
Solder Drifts			-0.5		+0.5	kPa
TEMPERATURE SENSOR						
Range			-40		85	°C
Resolution				0.003		°C
Accuracy		-40°C to 85°C	-1	±0.75	+1	°C
OPERATION						
Supply Voltage to GND ²	V_{SUPPLY}		2	3.0	5.5	V
Operating Temperature Range			-40		85	°C
I ² C Pull-Up Resistors	R_{PU}		1	2.2		kΩ

¹Guaranteed by design of 24bits ADC, and calculated according to the range in application.

² Factory calibrated for Pressure and Temperature at 3.0V±10%. Output accuracy will be affected if used outside this range. Other ranges available upon request.

1.3 ELECTRICAL PARAMETERS

PARAMETER	SYMBOL	CONDITIONS	MIN	TYP	MAX	UNITS
SUPPLY CURRENT						
Supply Current, average ¹ during conversion ² standby(no conversion)	I _{avg} I _{sc} I _{ss}	VDD=3V		3.95 1.5	0.2	μA mA μA
ANALOG TO DIGITAL CONVERTER						
Resolution	r _{ADC}				24	Bit
I ² C Clock Frequency	F _{C,I2C}				400	kHz
¹ Under the assumption of one conversion every second. Conversion means either a pressure or a temperature measurement ² During conversion, the sensor will be switched on to VDD, and after conversion ended, the sensor will automatically be switched off from VDD.						

2 OPERATION MODES

The CPS121-1500 is factory programmed to Sleep Mode. In this mode, the CPS121-1500 remains asleep until the master/host sends a measurement request (MR) before taking sensor measurements. After the CPS121-1500 receives an MR command, it wakes up, runs a full measurement cycle, stores the measurement data in internal registers and then returns to sleep mode again.

3 OUTPUT MODES

3.1 I²C

Two-wire I²C are available for reading sensor measurement data from the CPS121-1500. The interface is selectable by setting the digital voltage level on the SS pin:

- SS = 1 or float → I²C Mode

When SS=1 or not connected (internal pull-up at SS pin), I²C mode is selected.

The factory setting for the I²C slave address is 0x6C and the communication is restricted to this address only.

- I²C Address = 0x6C

3.2 I²C COMMANDS

Table 2 details the commands to interface with the device in the I²C modes.

TABLE 2: I²C COMMANDS

TYPE	DESCRIPTION	SUPPORT
Measurement Request (MR)	Wakes up the CPS121-1500, performs a sensor measurement, stores the sensor measurement data in internal registers and returns to sleep	I ² C
Get Data (GD)	Retrieves the sensor measurement data from the internal CPS121-1500 registers*.	I ² C

**Note: GD does not initiate a new measurement. Repeated GD commands will return the same (or stale) sensor measurement data. An MR is required to perform a full sensor measurement cycle to refresh the sensor register data.*

The Get Data (GD) command is used to read out data from the CPS121-1500. With the start of communication (for I²C after reading the slave address;) the entire sensor measurement output packet will be loaded in a serial output register. The register will be updated after the communication is finished. The output is always scaled to 24-bits.

The ordering of the bits is “big-endian”.

3.3 I²C GET DATA (GD)

An I²C Get Data command starts with the 7-bit slave address and the 8th bit = 1 (READ). The device then sends acknowledge (ACK), indicating I²C communication success. The number of data bytes returned by the device is determined by the master, which controls NACK and stop conditions.

Figure 1 displays an example for sending three bytes followed by reading five bytes. The first byte contains the I²C address followed by internal register address (0x06). Then the I²C address is repeated, followed by the slave sending out three pressure bytes and two temperature bytes.

The GD command is used to retrieve the pressure and temperature sensor data after an MR command has been executed.

Note that the two temperature byte codes are formatted in 2's complement.

FIGURE 1: SLAVE ADDRESS FOLLOWED BY THREE PRESSURE AND TWO TEMPERATURE BYTES

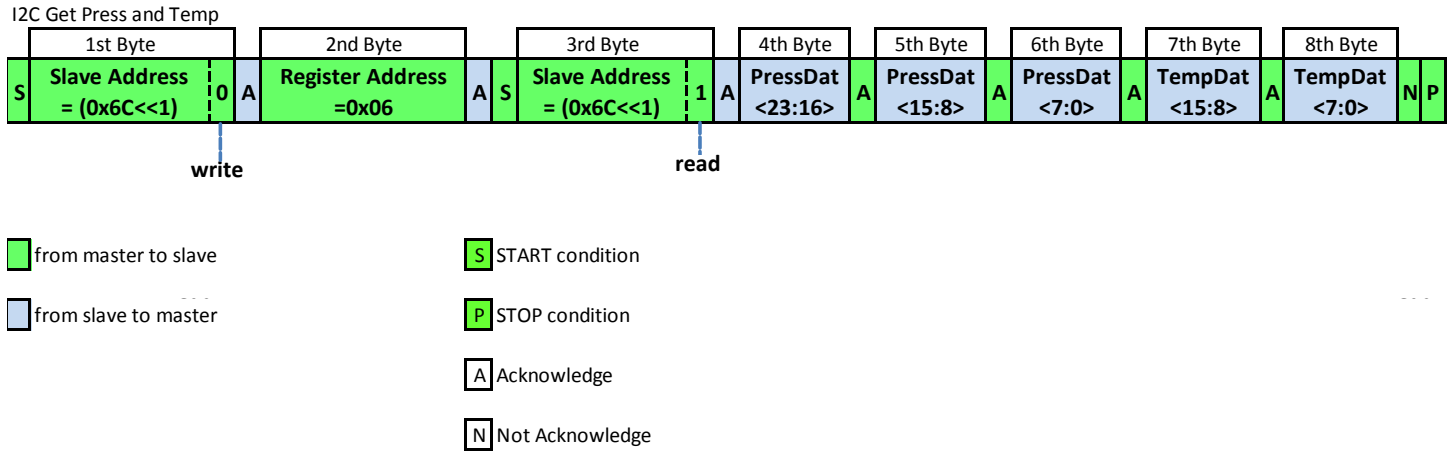

For Pressure data only, the data stream can be terminated after the sixth pressure byte. See Figure 2 below.

FIGURE 2: 7-BIT SLAVE ADDRESS FOLLOWED BY THREE PRESSURE BYTES

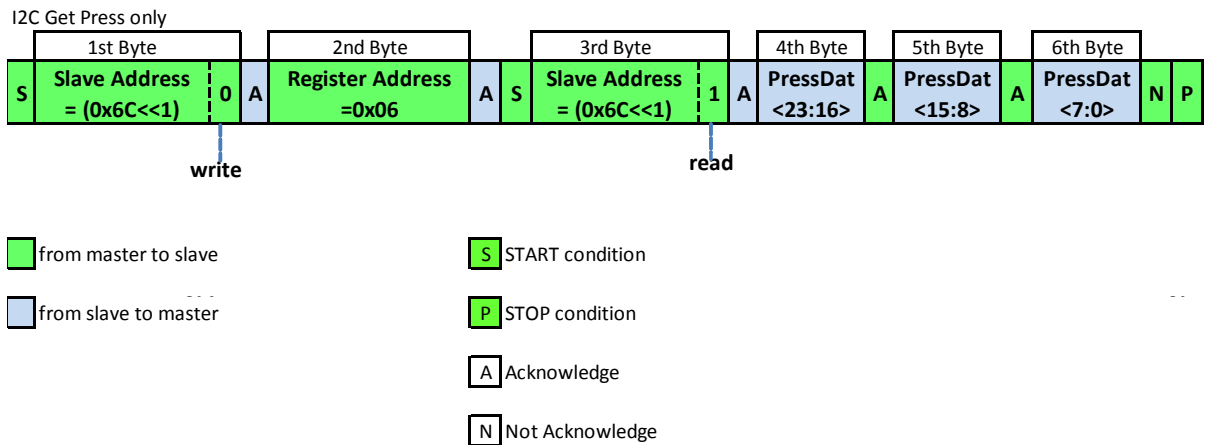

3.4 I²C MEASUREMENT REQUEST (MR)

The I²C MR is used to wake up the device from Sleep Mode and start a complete sensor measurement cycle, before the device returns to Sleep Mode again. The measurement cycles starts with a pressure measurement followed by a temperature measurement. The sensor measurements are digitized and run through an onboard compensation algorithm before the final measurement values are written to the digital output register. As shown in Figure 3, the communication requires the slave address (0x6C) and a WRITE bit (0) to initiate the MR. This is followed by two bytes; register address (0x30) and measurement (0xA). After the CPS121-1500 responds with the slave ACK, the master terminates the communication with a stop condition.

Sensor measurement conversion time takes approximately 5ms, so MRs should not be sent faster than every 5ms.

FIGURE 3: I²C MEASUREMENT REQUEST COMMAND

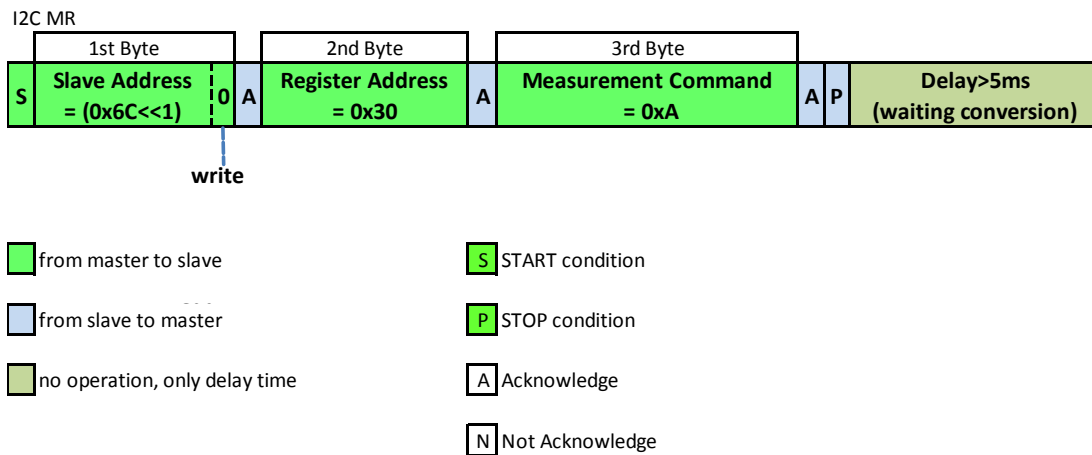

4 CALCULATING OUTPUT

After retrieving the data, the compensated output can be scaled to real world values by following the equations below.

4.1 PRESSURE OUTPUT

An example of the 24-bit compensated pressure with a full scale range of 50 to 1500kPa can be calculated as follows:

$$\text{Pressure [kPa]} = (\text{Pressure 3rd Byte [23:16]} \times 65536 + \text{Pressure 2nd Byte [15:8]} \times 256 + \text{Pressure 1st Byte [7:0]}) / 2^{16}/1000$$

4.2 TEMPERATURE OUTPUT

The 16-bit compensated temperature can be calculated as follows:

$$\text{Positive Temperature [}^{\circ}\text{C]} = (\text{Temperature High Byte [15:8]} \times 256 + \text{Temperature Low Byte [7:0]}) / 2^8$$

$$\text{Negative Temperature [}^{\circ}\text{C]} = (\text{Temperature High Byte [15:8]} \times 256 + \text{Temperature Low Byte [7:0]} - 65536) / 2^8$$

5 PACKAGE AND ASSEMBLY

The CPS121-1500 is available in an 8-pinLGA package.

5.1 PIN ASSEMBLY AND MECHANICAL DRAWING

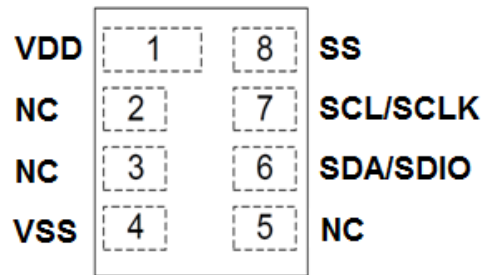

Pin	Name	Function
1	VDD	Power Supply, Connect 0.1uF CAP to GND
2	NC	Not Connect
3	NC	Not Connect
4	VSS	Ground
5	NC	Not Connect
6	SDA/SDIO	I2C Data and SPI data In/Out
7	SCL/SCLK	I2C and SPI Clock
8	SS	=1 or float I2C is selected, =0 SPI is selected

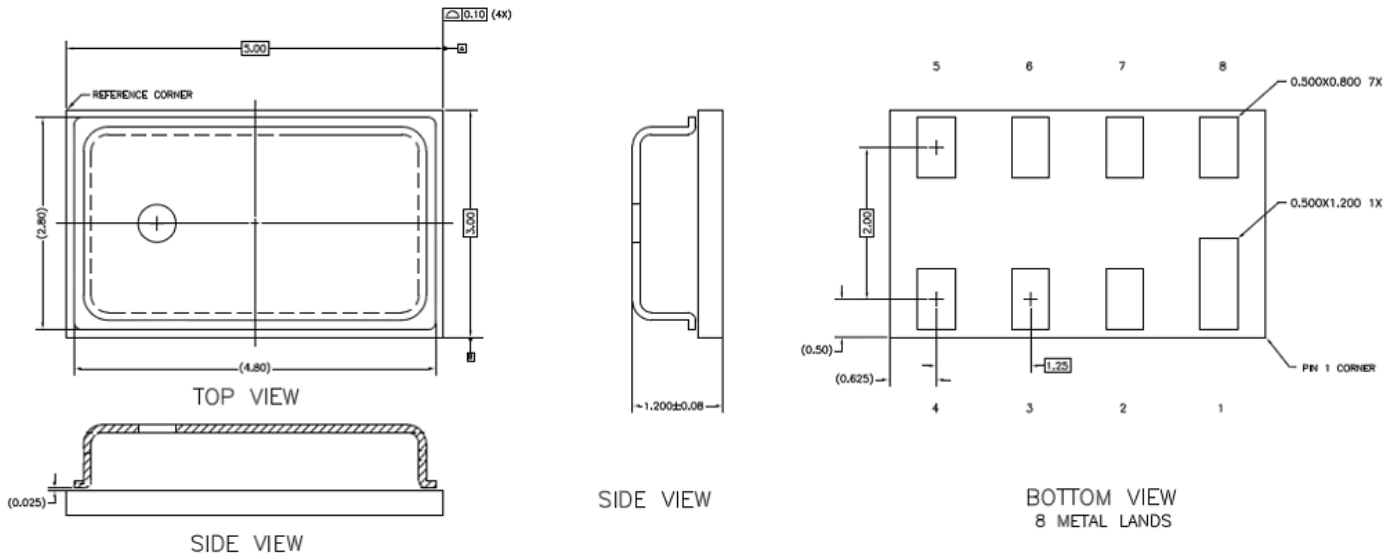

DIMENSION	MIN.	TYP.	MAX.	UNITS
Length		5		mm
Width		3		mm
Height		1.2		mm
Pad 1 Length		0.5		mm
Pad 1 Width		1.2		mm
Pad 2 to 8 Length		0.5		mm
Pad 2 to 8 Width		0.8		mm
Pad Pitch (Y-Axis)		2.0		mm
Pad Pitch (X-Axis)		1.25		mm
Port Hole Diameter		0.5		mm

5.2 SOLDERING CONDITIONS

TABLE4: PACKAGE REFLOW TEMPERATURE

PARAMETER	CONDITIONS	MIN	TYP	MAX	UNITS
Soldering Peak Temperature	Less than 30 seconds (JEDEC-STD-020 Standard)			260	°C

6 APPLICATION DIAGRAM

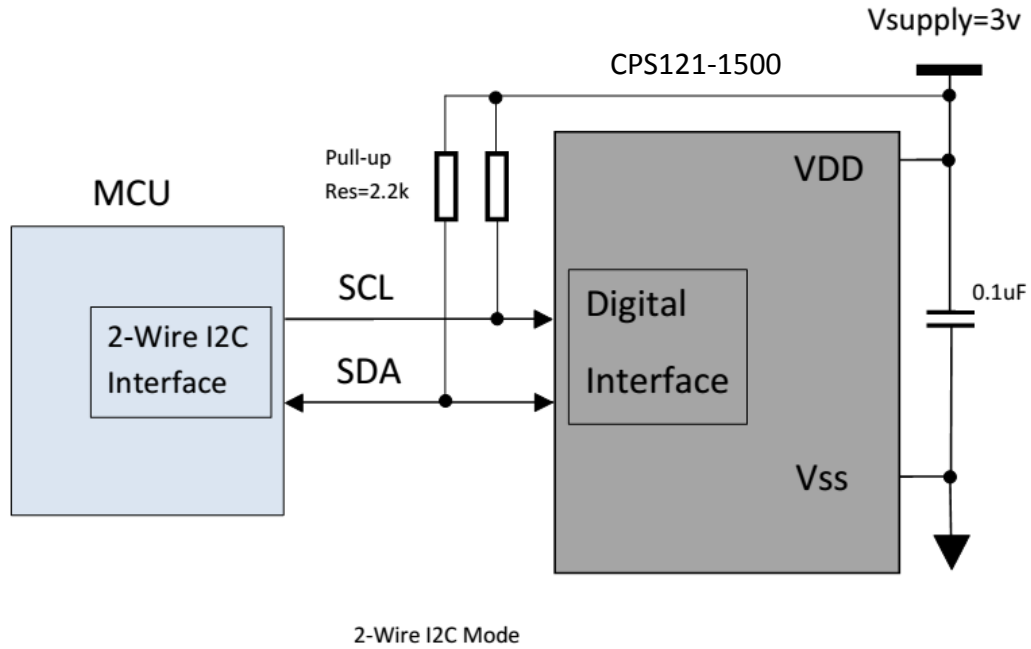

7 DOCUMENT HISTORY

REVISION	DATE	DESCRIPTION
1.0	FRBRUARY-2022	Preliminary

8 DISCLAIMER

Information in this datasheet is provided solely to enable implementation and use of Consensic products. The specifications and characteristics are subject to change without notice. Consensic reserves the right to make changes without further notice to any products herein.

“Typical” parameters provided in this datasheet can and do vary in different applications and actual performance may vary over time. Customers must validate all operating parameters for their application.

Consensic is not responsible for direct, indirect, incidental or consequential damages resulting from any defect, error or failure to perform. In no event, regardless of cause, shall Consensic incur any liability for any damages of any kind, including, but not limited to, any direct, indirect, special, incidental, punitive or consequential damages arising out of, resulting from, or any way connected to the use of the product, whether arising under breach of contract, tort (including negligence), strict liability or otherwise, and whether based on this agreement or otherwise, even if advised of the possibility of such damages, and whether or not injury was sustained by persons or property or otherwise; and whether or not loss was sustained from, or arose out of, the results of, the product, or any services that may be provided by Consensic.

The customer assumes all responsibility and liability for proper and safe handling of the goods. It is the customer’s responsibility to take any and all appropriate precautions with regard to electrostatic discharge. Also be aware that the products herein may not be regulatory compliant or agency certified (FCC, UL, CE, etc.).

No License is granted under any patent right or other intellectual property whatsoever. Consensic assumes no liability for applications assistance, customer product design, software performance, or infringement of patents or any other Intellectual property rights of any kind.