

修订 REV NO	标记 MARK	修改摘要 REVISION DESCRIPTION	签名 SIGNATURE	日期 DATE
		NEW DWG		2016-03-12

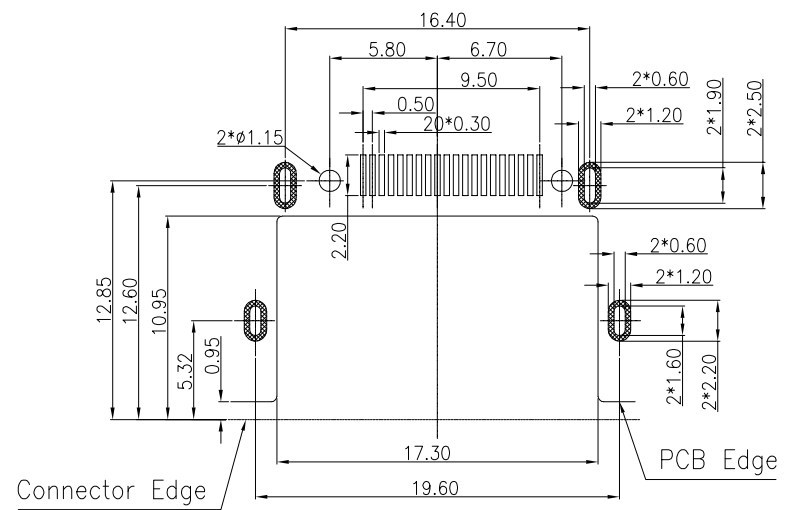

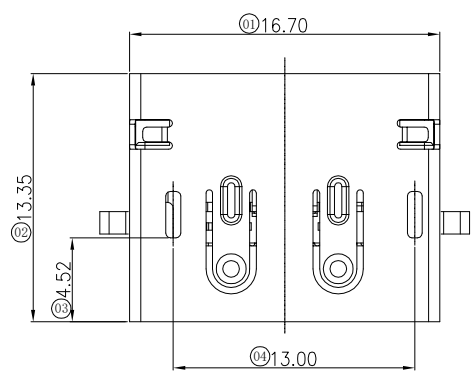

RECOMMENDED PCB LAYOUT
(THICKNESS=1.20±0.05mm)

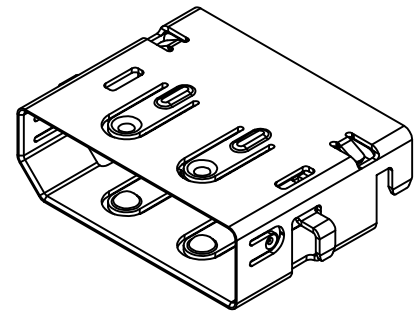
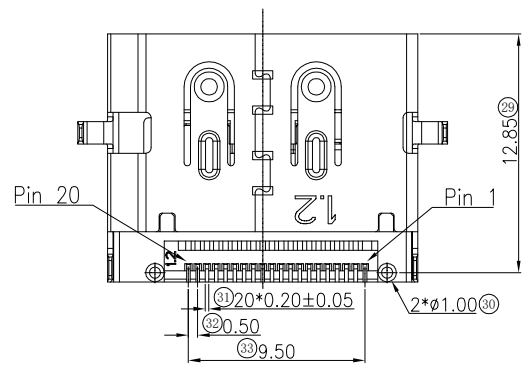
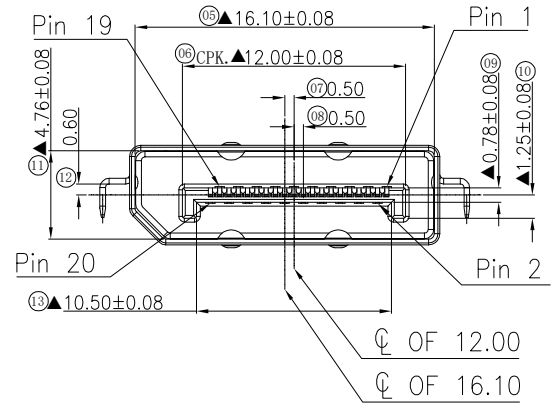
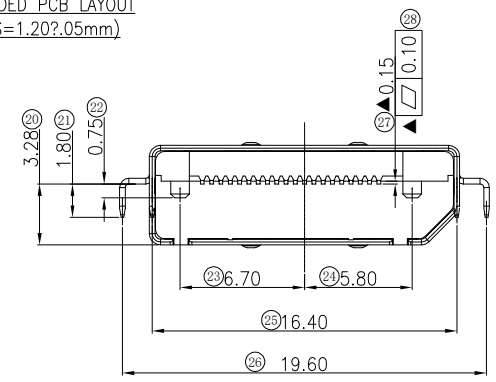
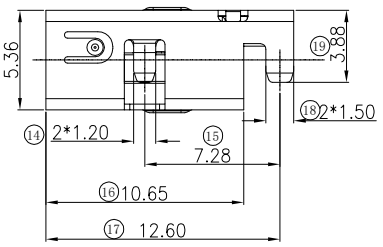

NOTE:

- A. MATERIAL:
- Housing: LCP(HF) UL94V-0 Black
 - Contact: Copper Alloy
 - Shell: Steel
- B. PLATING:
- Contact: Contact Area Gold Plated
Solder Area Sn Plated
Under Plated Nickel
 - Shell: Nickel Plated
- C. SPECIFICATION:
- Current: 0.5A
 - Voltage: 40V RMS
 - Withstanding Voltage: 500V AC
 - Contact Resistance: $\Delta R=30\text{ m}\Omega$ max. (Contact)
 $\Delta R=50\text{ m}\Omega$ max. (Shell)
 - Insulation Resistance: 100 M Ω min.
 - Temperature Range: -20°C to +85°C
 - Mating And unmating Force:
 - Mating Force: 4.5Kgf(44.1N)Max.
 - Unmating Force: 1.0Kgf~4.0Kgf(9.8N~39.2N)
 - Durability: 10000 Cycles

		深圳市华德共创科技有限公司 Shenzhen Huade co-create Technology Co.,LTD 电话: 0755-23304126 传真: 0755-29940187						
-TOLERANCES- UNLESS OTHERWISE SPECIFIED 公差参数表		 		TITLE: 大DP沉板母座1.2 不锈钢镀 产品名称: 镍黑胶CL-0.6				
X.X	±0.30	X.X*	±3°	APPD: 核准:	PART NO: 产品编号: DP-GD-119PWB			
X.XX	±0.20	X.XX*	±2°	CHECK: 校对: 王建业	DATE	SCALE	UNIT	CODE NUMBER
X.XXX	±0.10	X.XXX*	±1°	DRAW: 绘图: 黄艳兰	2016-03-12	1:1	mm	A001