

Features

- High Blocking Voltage with Low On-Resistance
- High Speed Switching with Low Capacitances
- Easy to Parallel and Simple to Drive
- Avalanche Ruggedness
- Halogen Free, RoHS Compliant

Benefits

- Higher System Efficiency
- Reduced Cooling Requirements
- Increased Power Density
- Increased System Switching Frequency

Applications

- Solar Inverters
- Switch Mode Power Supplies
- High Voltage DC/DC Converters
- Battery Chargers
- Motor Drives
- Pulsed Power applications

Package

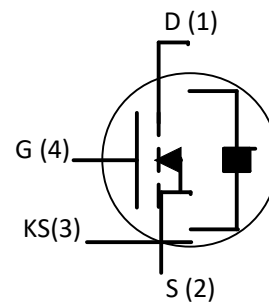
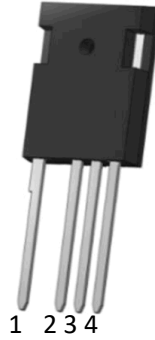

Electrical Characteristics

Symbol	Parameter	Min.	Typ.	Max.	Unit	Test Conditions	Note
$V_{(BR)DSS}$	Drain-Source Breakdown Voltage	1200			V	$V_{GS}=0V, I_D=100\mu A$	
$V_{GS(th)}$	Gate Threshold Voltage	2.0	2.4	4.0	V	$V_{GS}=V_{DS}, I_{DS}=5mA, T_C=25^\circ C$	Fig. 6
			1.73			$V_{GS}=V_{DS}, I_{DS}=5mA, T_C=150^\circ C$	
I_{DSS}	Zero Gate Voltage Drain Current		1	100	μA	$V_{DS}=1200V, V_{GS}=0V$	
I_{GSS}	Gate-Source Leakage Current		20	200	nA	$V_{GS}=20V, V_{DS}=0V$	
$R_{DS(on)}$	Drain-Source on-state Resistance		80	98	m Ω	$V_{GS}=20V, I_D=20A, T_C=25^\circ C$	Fig. 4
			120			$V_{GS}=20V, I_D=20A, T_C=150^\circ C$	
g_{fs}	Transconductance		7.0		S	$V_{GS}=20V, I_D=20A, T_J=25^\circ C$	Fig. 5
			6.6			$V_{GS}=20V, I_D=20A, T_J=150^\circ C$	
C_{iss}	Input Capacitance		2016		pF	$V_{GS}=0V, V_{DS}=1000V, f=1MHz$ $V_{AC}=25mV$	Fig. 8
C_{oss}	Output Capacitance		72.6				
C_{rss}	Reverse Transfer Capacitance		17.9				
E_{ON}	Turn-On Switching Energy		180		μJ	$V_{DS}=800V, V_{GS}=-5/20V, I_D=20A,$ $R_{G(ext)}=5\Omega, L=142\mu H$	
E_{OFF}	Turn-Off Switching Energy		70				
$t_{d(on)}$	Turn-On Delay Time		23		ns	$V_{DD}=800V, V_{GS}=-5/20V$ $I_D=20A, R_{G(ext)}=5\Omega,$ $R_L=40\Omega, \text{Timing relative to } V_{DS}$	
t_r	Rise Time		60				
$t_{d(off)}$	Turn-Off Delay Time		17				
t_f	Fall Time		12				
$R_{G(int)}$	Internal Gate Resistance		2.8		Ω	$f=1MHz, V_{AC}=25mV$	
Q_{gs}	Gate to Source Charge		23		nC	$V_{DD}=800V, V_{GS}=-5/20V$ $I_D=20A$	Fig. 9
Q_{gd}	Gate to Drain Charge		26				
Q_g	Total Gate Charge		85				

Reverse Diode Characteristics

Symbol	Parameter	Typ.	Max.	Unit	Test Conditions	Note
V_{SD}	Diode Forward Voltage	3.5		V	$V_{GS}=-5V, I_{SD}=10A, T_J=25^\circ C$	Fig. 7
		3.3		V	$V_{GS}=-5V, I_{SD}=10A, T_J=150^\circ C$	
I_S	Continuous Diode Forward Current		28	A	$T_C=25^\circ C$	
t_{rr}	Reverse Recovery time	18		ns	$V_{GS}=-5V, I_{SD}=20A, V_R=800V,$ $dif/dt=1200A/\mu s;$	
Q_{rr}	Reverse Recovery Charge	80		nC		
I_{rrm}	Peak Reverse Recovery Current	8.0		A		

Thermal Characteristics

Symbol	Parameter	Typ.	Unit	Test Conditions	Note
$R_{\theta JC}$	Thermal Resistance from Junction to Case	0.75	$^\circ C/W$		Fig. 11
$R_{\theta JA}$	Thermal Resistance From Junction to Ambient	35			

Typical Performance

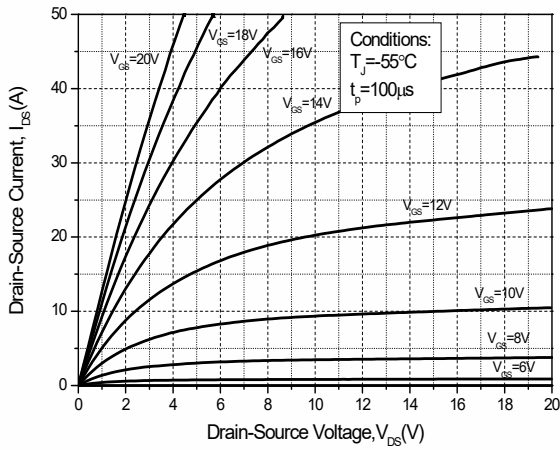

Figure 1. Output Characteristics $T_J = -55^\circ\text{C}$

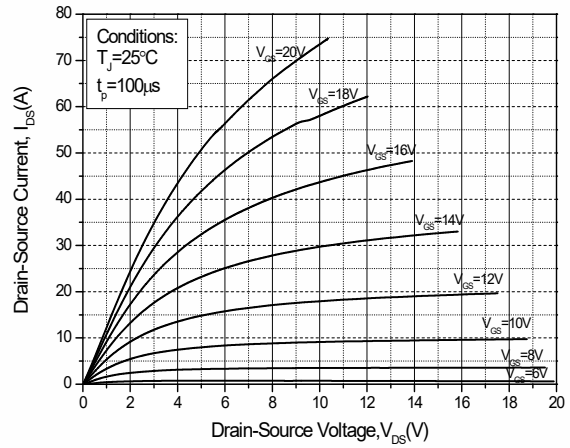

Figure 2. Output Characteristics $T_J = 25^\circ\text{C}$

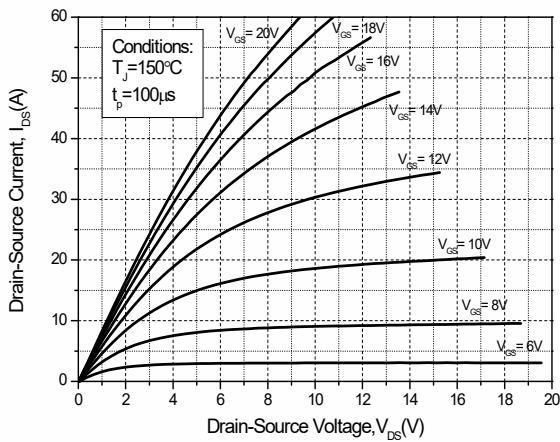

Figure 3. Output Characteristics $T_J = 150^\circ\text{C}$

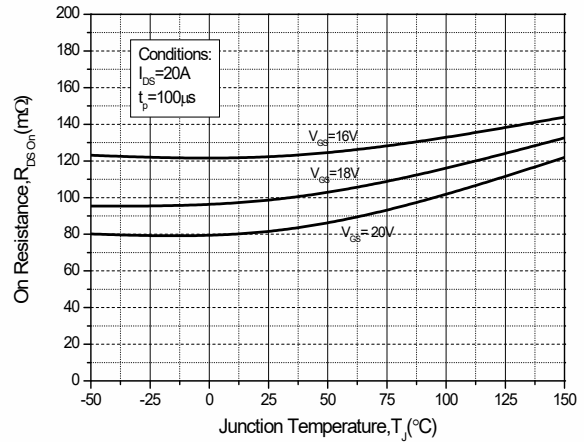

Figure 4. On-Resistance For Various Gate Voltage

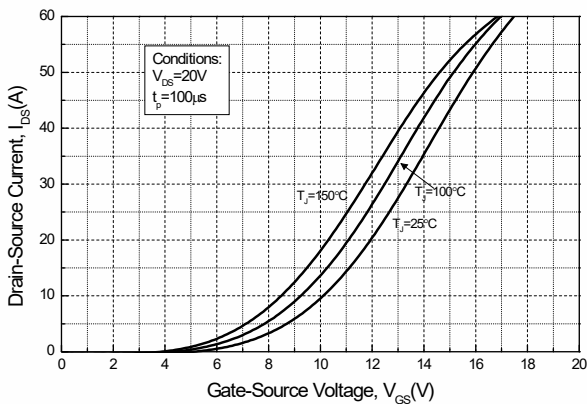

Figure 5. Transfer Characteristic for Various Junction Temperatures

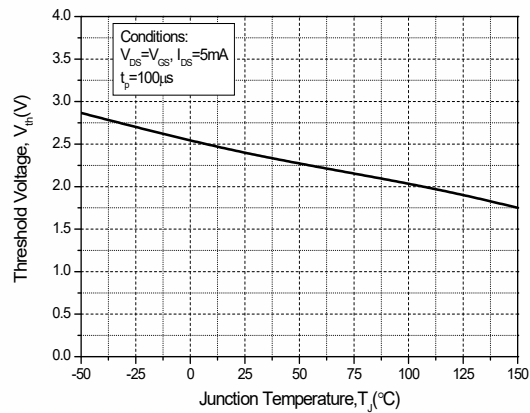

Figure 6. Threshold Voltage vs. Temperature

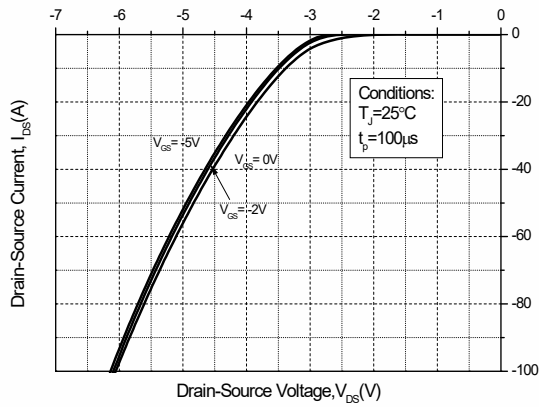

Figure 7. Body Diode Characteristics

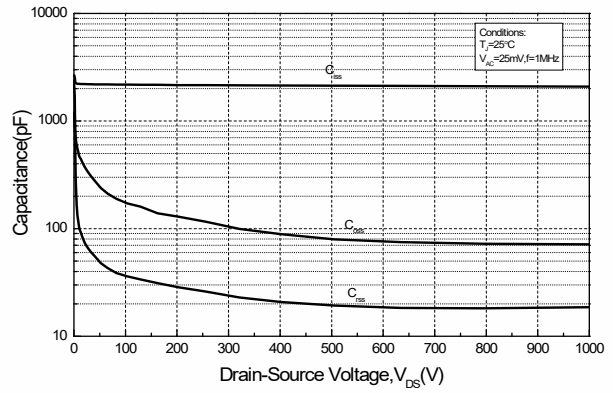

Figure 8. Capacitances vs. Drain-Source Voltage

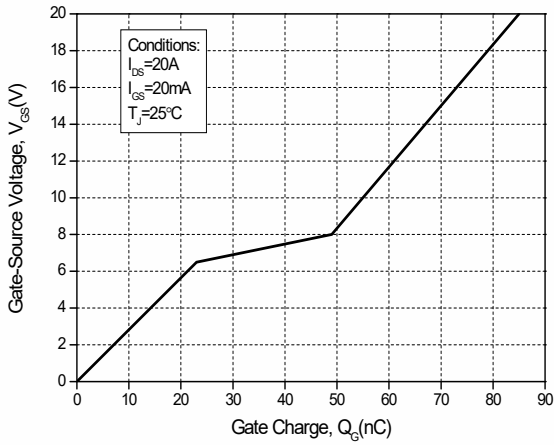

Figure 9. Gate Charge Characteristics

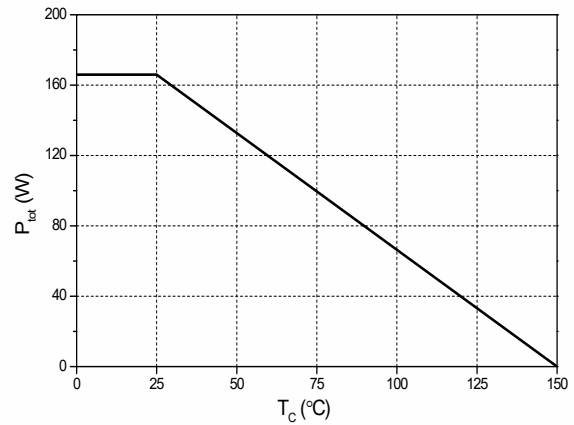

Figure 10. Power Dissipation Derating

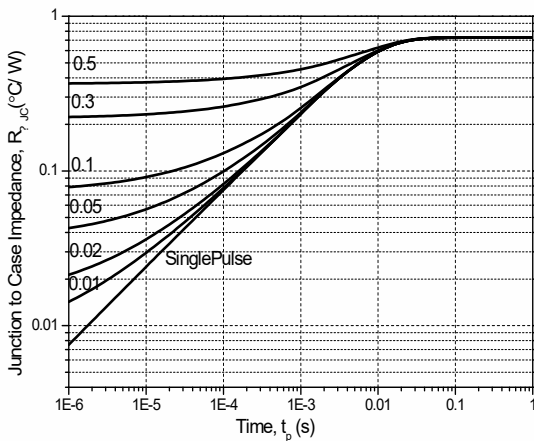
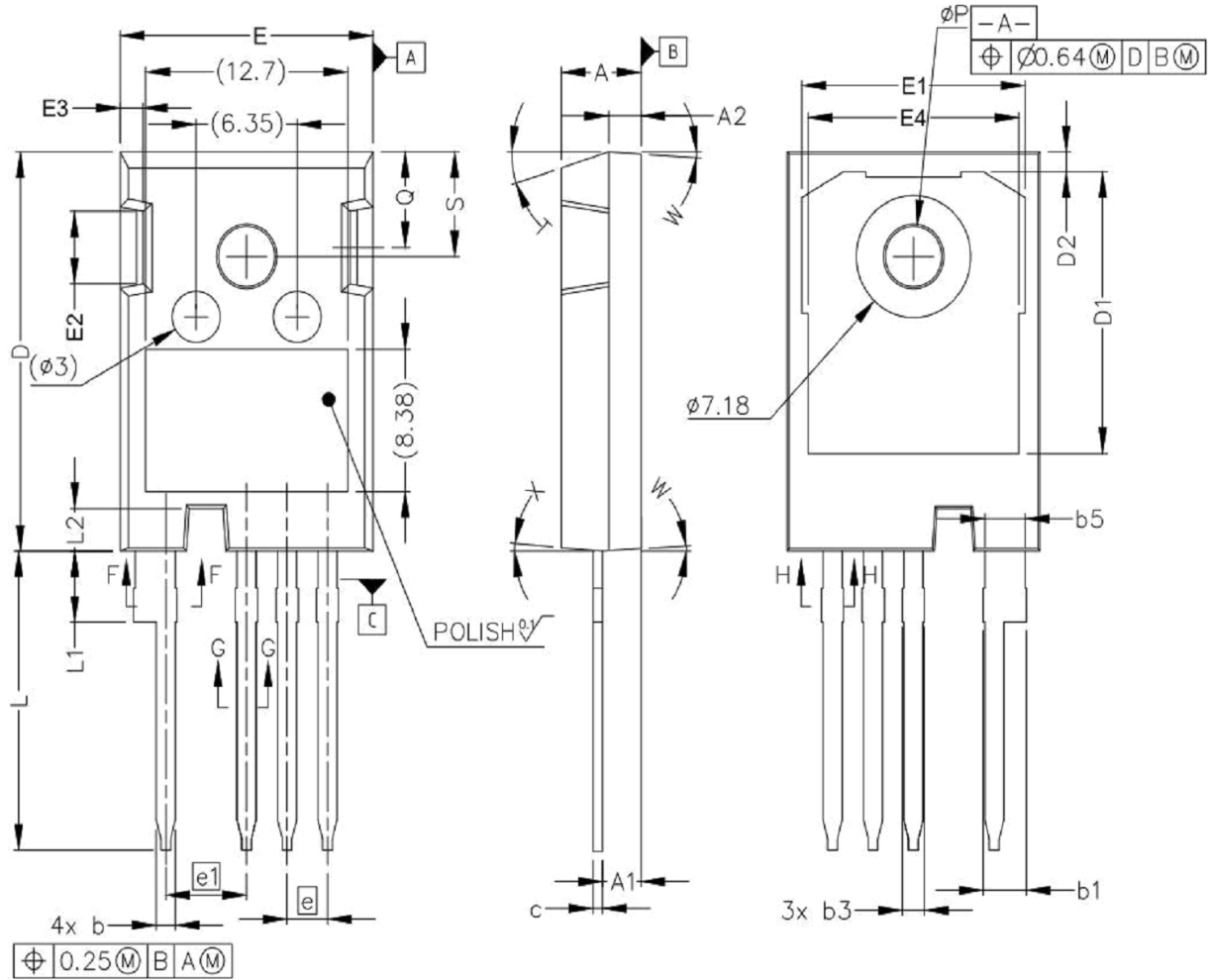

Figure 11. Transient Thermal Impedance

Package Dimensions: TO-247-4L



SYMBOL	Mechanical Dimensions/mm			SYMBOL	Mechanical Dimensions/mm			SYMBOL	Mechanical Dimensions/mm		
	MIN	NOM	MAX						MIN	NOM	MAX
A	4.83	5.00	5.21	D	23.30	23.45	23.60	L1	3.97	4.13	4.37
A1	2.29	2.41	2.54	D1	16.25	16.55	17.65	ϕP	3.51	3.6	3.65
A2	1.91	2.00	2.16	E	15.75	15.90	16.13	W	-	3.5	-
b	1.07	1.20	1.33	E1	13.10	13.65	14.15	X	-	4	-
b1	2.39	2.60	2.94	E2	3.68	5.0	5.1	Q	5.49	5.8	6.0
b2	2.39	-	2.84	e	2.54			S	6.04	6.15	6.30
c	0.55	0.60	0.68	L	17.31	17.45	17.82	T	-	17.5	-

NOTE:
 1.The plastic package is not marked as smooth surfaceRa=0.1;Subglossy surfaceRa=0.8
 2.Undeclared tolerance ± 0.15 , Unmarked filletRmax=0.25

NAME	TO-247-4L OUTLINE	UNIT	mm	DESIGNED	Shawn	THIRD ANGLE SYSTEM
DWGNO		PAGE	1 OF 1	CHECKED		
VERSION	Ver1.0	ISSUE DATE		APPROVED		