

MATERIAL:
 HOUSING: LCP,UL94V-0,BLACK.
 TERMINALS BRACKET: LCP,UL94V-0,BLACK.
 SHIELD: C2680,T=0.20MM,NICKEL PLATING ON ALL AREA.
 TERMINAL: PHOSPHOR BRONZE C5210,T=0.35MM,
 6U" GOLD PLATING ON CONTACT AREA.

MECHANICAL:
 DURABILITY: 750 CYCLES MIN.
 MATING FORCE: 23N MAX.
 OPERATING TEMPERATURE: -40°C~+85°C.
 STORAGE TEMPERATURE: -40°C~+85°C.
 ALL CRITICAL DIMENSIONS WITH "*"

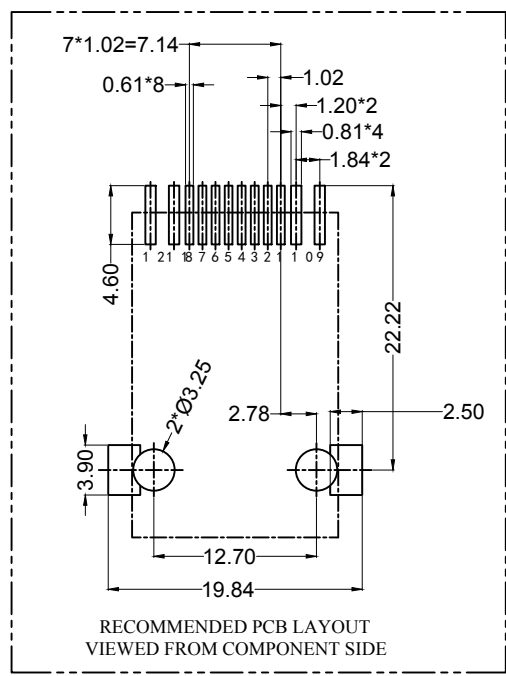

RECOMMENDED PCB LAYOUT
 VIEWED FROM COMPONENT SIDE

			GENERAL TOLERANCE		制图 DRAWING		深圳市华灿天禄电子有限公司 ShenzhenhuacantianluELECTRONICS CO.,LTD			
			DIM	TOL	审核 CHECK					
			X.X	±0.30	批准 APPROVAL		产品名称 TITLE	网络插座 (贴片 TAB-UP 1x1 100BASE)	版本 REV.	A
1			初版发行				产品料号 PART NO.	HC961160C-906-A	单位 UNITS	mm
序号 No.	变更内容 MODIFY CONTENT	日期 MODIFY DATE	Angle ±3.0°		投影 Projection		材料 MATERIAL		页次 SHEET	1/3

PCB SIDE TO PHY

CABLE SIDE

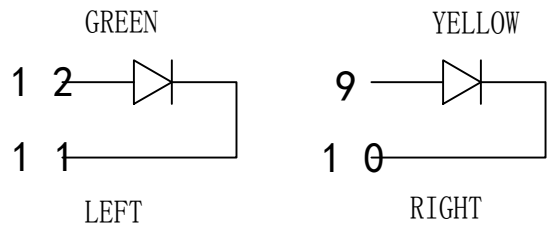
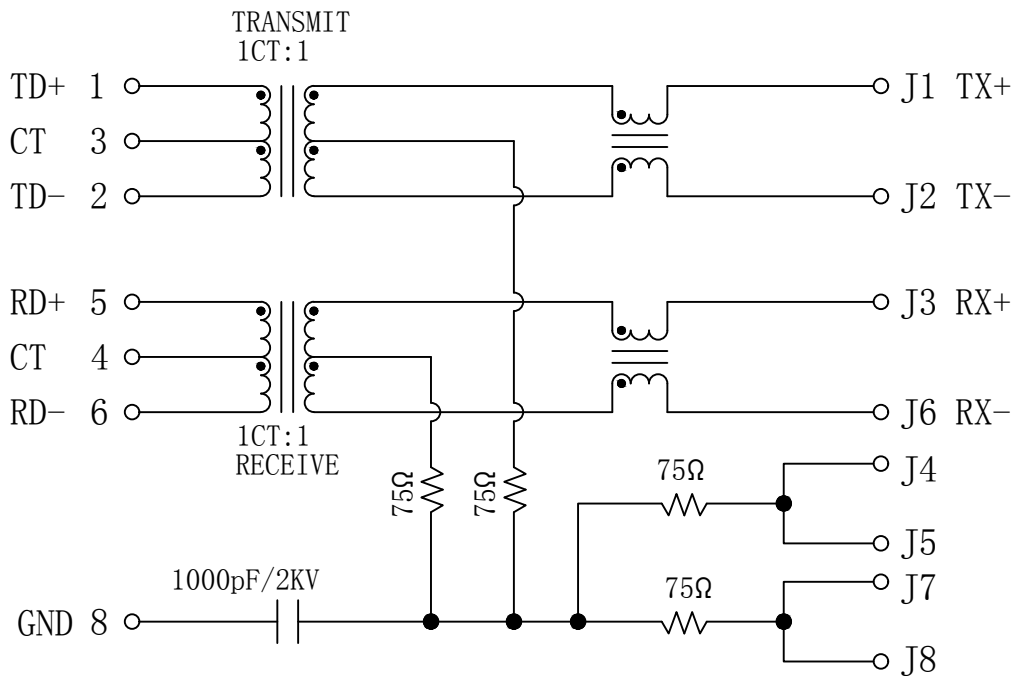

Electrical:

1. Turn ratio: 1~2: J1~J2=1CT:1CT(±2%).
5~6: J3~J6=1CT:1CT(±2%).
2. OCL: 350uH Min. at 100KHz 100mV 8mA DC.
3. Insertion Loss: -1.0 dB Max 1~100MHz.
4. Return loss: -20dB Min 1~10MHz;
-16dB Min 10~30MHz;
-12dB Min 30~60MHz;
-10dB Min 60~80MHz.
5. Cross talk: -40dB Min 1~30MHz;
-35dB Min 30~60MHz;
-30dB Min 60~100MHz;
6. CMR: -30dB Min 1~100MHz;
7. Hi-Pot: 1500V AC & 2250V DC
6S 1mA PRI TO SEC

LED Specification

Standard LED Color	LED Wavelength	Foward(A)	Foward(V)
Green	568nm	20mA	1.85-2.45V
Yellow	585nm	20mA	1.7-2.2V

			GENERAL TOLERANCE		制图 DRAWING		深圳市华灿天禄电子有限公司 ShenzhenhuacantianluELECTRONICS CO., LTD			
			DIM	TOL	审核 CHECK					
			X.X	±0.30	批准 APPROVAL		产品名称 TITLE	网络插座 (贴片 TAB-UP 1x1 100BASE)	版本 REV.	A
1			初版发行				产品料号 PART NO.	HC961160C-906-A	单位 UNITS	mm
序号 No.	变更内容 MODIFY CONTENT	日期 MODIFY DATE	Angle	±3.0°	投影 Projection		材料 MATERIAL		页次 SHEET	2/3

PROFILE OF REFLOW SOLDERING

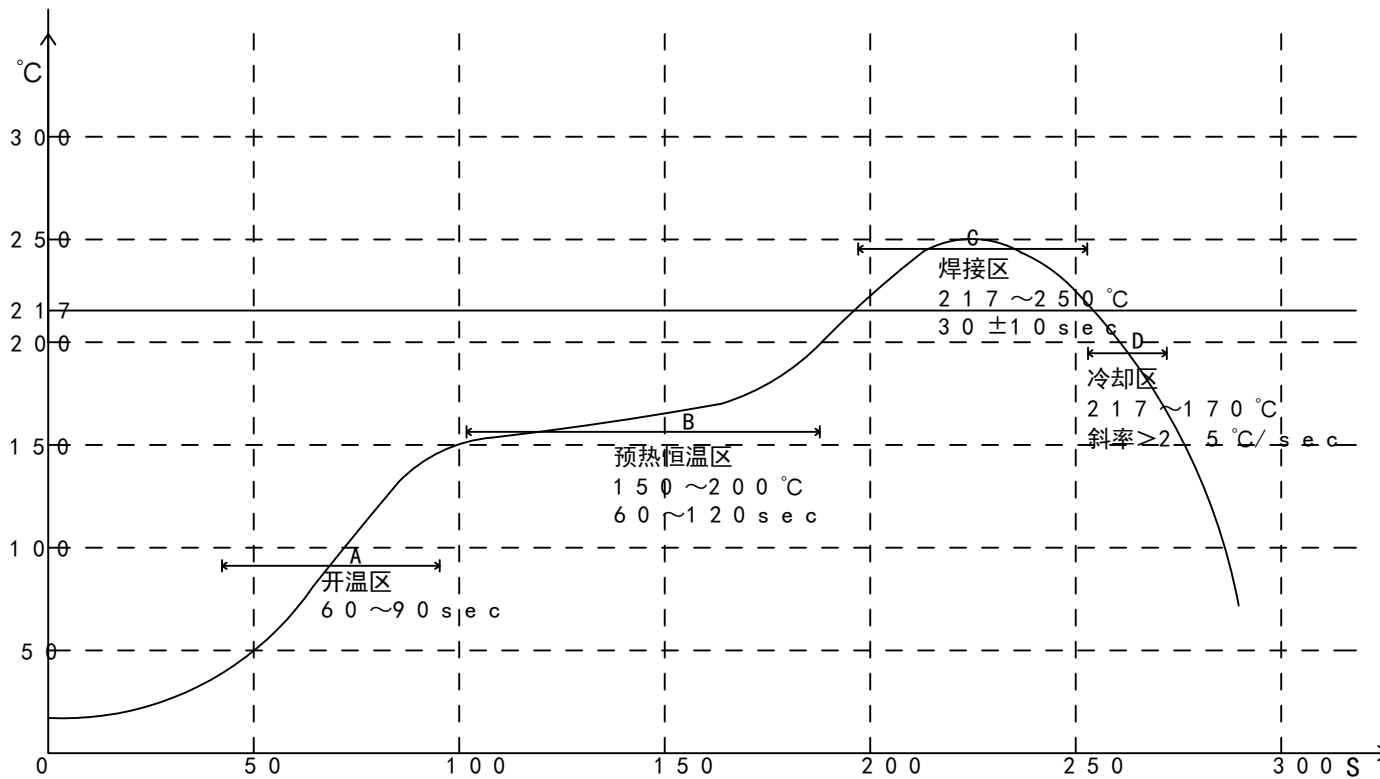

A. Temperature range of open
 B. Preheat temperature zone
 C. The welding zone
 D. The cooling zone
 Tip temperature: 265±5°C.
 Tip temperature time: 3.0 ± 1.0 s.
 Tip melting point of Sn96.5/Ag3/Cu0.5.

			GENERAL TOLERANCE		制图 DRAWING		深圳市华灿天禄电子有限公司 ShenzhenhuacantianluELECTRONICS CO., LTD				
			DIM	TOL	审核 CHECK		产品名称 TITLE		网络插座 (贴片 TAB-UP 1x1 100BASE)	版本 REV.	A
			X.X	±0.30	批准 APPROVAL		产品料号 PART NO.		HC961160C-906-A	单位 UNITS	mm
1 初版发行			X.XX	±0.10	比例 SCALE		材料 MATERIAL			页次 SHEET	3/3
序号 No.			变更内容 MODIFY CONTENT		日期 MODIFY DATE		投影 Projection				