

Single Supply Quad Operational Amplifiers

The HT324 series are low-cost, quad operational amplifiers with true differential inputs. They have several distinct advantages over standard operational amplifier types in single supply applications. The quad amplifier can operate at supply voltages as low as 3.0 V or as high as 32 V with quiescent currents about one-fifth of those associated with the MC1741 (on a per amplifier basis). The common mode input range includes the negative supply, thereby eliminating the necessity for external biasing components in many applications. The output voltage range also includes the negative power supply voltage.

Features

- Short Circuited Protected Outputs
- True Differential Input Stage
- Single Supply Operation: 3.0 V to 32 V
- Low Input Bias Currents: 100 nA Maximum (HT324A)
- Four Amplifiers Per Package
- Internally Compensated
- Common Mode Range Extends to Negative Supply
- Industry Standard Pinouts
- ESD Clamps on the Inputs Increase Ruggedness without Affecting Device Operation
- NCV Prefix for Automotive and Other Applications Requiring Unique Site and Control Change Requirements; AEC-Q100 Qualified and PPAP Capable
- These Devices are Pb-Free, Halogen Free/BFR Free and are RoHS Compliant

PIN CONNECTIONS

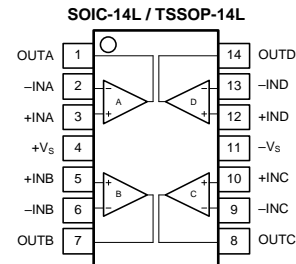
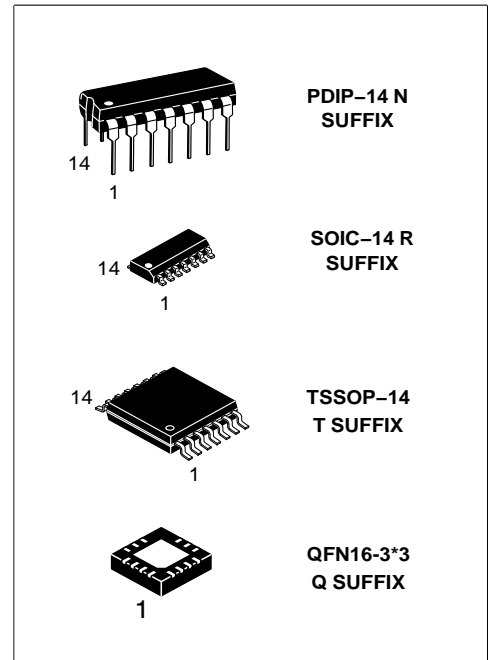
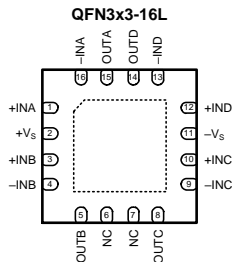

MAXIMUM RATINGS ($T_A = +25^\circ\text{C}$, unless otherwise noted.)

Rating	Symbol	Value	Unit
Power Supply Voltages Single Supply Split Supplies	V_{CC} V_{CC}, V_{EE}	32 ± 16	Vdc
Input Differential Voltage Range (Note 1)	V_{IDR}	± 32	Vdc
Input Common Mode Voltage Range	V_{ICR}	-0.3 to 32	Vdc
Output Short Circuit Duration	t_{SC}	Continuous	
Junction Temperature	T_J	150	$^\circ\text{C}$
Thermal Resistance, Junction-to-Air (Note 2)	Case 646 Case 751A Case 948G $R_{\theta JA}$	118 156 190	$^\circ\text{C}/\text{W}$
Storage Temperature Range	T_{stg}	-65 to +150	$^\circ\text{C}$
Operating Ambient Temperature Range	T_A	HT224A HT324A HT2902A, HT2902B (Note 3) -25 to +85 0 to +70 -40 to +105 -40 to +125	$^\circ\text{C}$

Stresses exceeding those listed in the Maximum Ratings table may damage the device. If any of these limits are exceeded, device functionality should not be assumed, damage may occur and reliability may be affected.

1. Split Power Supplies.
2. All $R_{\theta JA}$ measurements made on evaluation board with 1 oz. copper traces of minimum pad size. All device outputs were active.
3. HT2902B is qualified for automotive use.

ESD RATINGS

Rating	HBM	MM	Unit
ESD Protection at any Pin (Human Body Model – HBM, Machine Model – MM)			
HT2902B (Note 3)	2000	200	V
HT2902A	2000	200	V
HT324A	200	100	V
All Other Devices	2000	200	V

ELECTRICAL CHARACTERISTICS ($V_{CC} = 5.0\text{ V}$, $V_{EE} = \text{GND}$, $T_A = 25^\circ\text{C}$, unless otherwise noted.)

Characteristics	Symbol	HT224A			HT324A			HT324B			HT2902A			HT2902B			Unit
		Min	Typ	Max	Min	Typ	Max	Min	Typ	Max	Min	Typ	Max	Min	Typ	Max	
Input Offset Voltage $V_{CC} = 5.0\text{ V}$ to 30 V $V_{ICR} = 0\text{ V}$ to $V_{CC} - 1.7\text{ V}$, $V_O = 1.4\text{ V}$, $R_S = 0\ \Omega$ $T_A = 25^\circ\text{C}$ $T_A = T_{\text{high}}$ (Note 4) $T_A = T_{\text{low}}$ (Note 4)	V_{IO}	-	2.0	5.0	-	2.0	3.0	-	2.0	7.0	-	2.0	7.0	-	2.0	7.0	mV
Average Temperature Coefficient of Input Offset Voltage $T_A = T_{\text{high}}$ to T_{low} (Notes 4 and 6)	$\Delta V_{IO}/\Delta T$	-	7.0	-	-	7.0	30	-	7.0	-	-	7.0	-	-	7.0	-	$\mu\text{V}/^\circ\text{C}$
Input Offset Current $T_A = T_{\text{high}}$ to T_{low} (Note 4)	I_{IO}	-	3.0	30	-	5.0	30	-	5.0	50	-	5.0	50	-	5.0	50	nA
Average Temperature Coefficient of Input Offset Current $T_A = T_{\text{high}}$ to T_{low} (Notes 4 and 6)	$\Delta I_{IO}/\Delta T$	-	10	-	-	10	300	-	10	-	-	10	-	-	10	-	$\text{pA}/^\circ\text{C}$
Input Bias Current $T_A = T_{\text{high}}$ to T_{low} (Note 4)	I_{IB}	-	-90	-150	-	-45	-100	-	-90	-250	-	-90	-250	-	-90	-250	nA
Input Common Mode Voltage Range (Note 5) $V_{CC} = 30\text{ V}$ $T_A = +25^\circ\text{C}$ $T_A = T_{\text{high}}$ to T_{low} (Note 4)	V_{ICR}	0	-	28.3	0	-	28.3	0	-	28.3	0	-	28.3	0	-	28.3	V
Differential Input Voltage Range	V_{IDR}	-	-	V_{CC}	-	-	V_{CC}	-	-	V_{CC}	-	-	V_{CC}	-	-	V_{CC}	V
Large Signal Open Loop Voltage Gain $R_L = 2.0\text{ k}\Omega$, $V_{CC} = 15\text{ V}$, for Large V_O Swing $T_A = T_{\text{high}}$ to T_{low} (Note 4)	A_{VOL}	50	100	-	25	100	-	25	100	-	25	100	-	25	100	-	V/mV
Channel Separation $10\text{ kHz} \leq f \leq 20\text{ kHz}$, Input Referenced	CS	-	-120	-	-	-120	-	-	-120	-	-	-120	-	-	-120	-	dB
Common Mode Rejection, $R_S \leq 10\text{ k}\Omega$	CMR	70	85	-	65	70	-	65	70	-	50	70	-	50	70	-	dB
Power Supply Rejection	PSR	65	100	-	65	100	-	65	100	-	50	100	-	50	100	-	dB

4. HT224A: $T_{\text{low}} = -25^\circ\text{C}$, $T_{\text{high}} = +85^\circ\text{C}$
 HT324A/B: $T_{\text{low}} = 0^\circ\text{C}$, $T_{\text{high}} = +70^\circ\text{C}$
 HT2902A: $T_{\text{low}} = -40^\circ\text{C}$, $T_{\text{high}} = +105^\circ\text{C}$
 HT2902B: $T_{\text{low}} = -40^\circ\text{C}$, $T_{\text{high}} = +125^\circ\text{C}$
 HT2902 is qualified for automotive use.

5. The input common mode voltage or either input signal voltage should not be allowed to go negative by more than 0.3 V. The upper end of the common mode voltage range is $V_{CC} - 1.7\text{ V}$, but either or both inputs can go to +32 V without damage, independent of the magnitude of V_{CC} .
6. Guaranteed by design.

ELECTRICAL CHARACTERISTICS ($V_{CC} = 5.0\text{ V}$, $V_{EE} = \text{GND}$, $T_A = 25^\circ\text{C}$, unless otherwise noted.)

Characteristics	Symbol	HT224A			HT324A			HT324B			HT2902A			HT2902B			Unit
		Min	Typ	Max	Min	Typ	Max	Min	Typ	Max	Min	Typ	Max	Min	Typ	Max	
Output Voltage – High Limit $V_{CC} = 5.0\text{ V}$, $R_L = 2.0\text{ k}\Omega$, $T_A = 25^\circ\text{C}$	V_{OH}	3.3	3.5	–	3.3	3.5	–	3.3	3.5	–	3.3	3.5	–	3.3	3.5	–	V
$V_{CC} = 30\text{ V}$ $R_L = 2.0\text{ k}\Omega$ ($T_A = T_{\text{high}}$ to T_{low}) (Note 7)		26	–	–	26	–	–	26	–	–	26	–	–	26	–	–	
$V_{CC} = 30\text{ V}$ $R_L = 10\text{ k}\Omega$ ($T_A = T_{\text{high}}$ to T_{low}) (Note 7)		27	28	–	27	28	–	27	28	–	27	28	–	27	28	–	
Output Voltage – Low Limit, $V_{CC} = 5.0\text{ V}$, $R_L = 10\text{ k}\Omega$, $T_A = T_{\text{high}}$ to T_{low} (Note 7)	V_{OL}	–	5.0	20	–	5.0	20	–	5.0	20	–	5.0	100	–	5.0	100	mV
Output Source Current ($V_{ID} = +1.0\text{ V}$, $V_{CC} = 15\text{ V}$) $T_A = 25^\circ\text{C}$ $T_A = T_{\text{high}}$ to T_{low} (Note 7)	I_{O+}	20	40	–	20	40	–	20	40	–	20	40	–	20	40	–	mA
Output Sink Current ($V_{ID} = -1.0\text{ V}$, $V_{CC} = 15\text{ V}$) $T_A = 25^\circ\text{C}$ $T_A = T_{\text{high}}$ to T_{low} (Note 7)	I_{O-}	10	20	–	10	20	–	10	20	–	10	20	–	10	20	–	mA
		5.0	8.0	–	5.0	8.0	–	5.0	8.0	–	5.0	8.0	–	5.0	8.0	–	
		($V_{ID} = -1.0\text{ V}$, $V_O = 200\text{ mV}$, $T_A = 25^\circ\text{C}$)	12	50	–	12	50	–	12	50	–	–	–	–	–	–	–
Output Short Circuit to Ground (Note 8)	I_{SC}	–	40	60	–	40	60	–	40	60	–	40	60	–	40	60	mA
Power Supply Current ($T_A = T_{\text{high}}$ to T_{low}) (Note 7)	I_{CC}	–	–	3.0	–	1.4	3.0	–	–	3.0	–	–	3.0	–	–	3.0	mA
$V_{CC} = 30\text{ V}$ $V_O = 0\text{ V}$, $R_L = \infty$		–	–	3.0	–	1.4	3.0	–	–	3.0	–	–	3.0	–	–	3.0	
$V_{CC} = 5.0\text{ V}$, $V_O = 0\text{ V}$, $R_L = \infty$		–	–	1.2	–	0.7	1.2	–	–	1.2	–	–	1.2	–	–	1.2	

 7. HT224A: $T_{\text{low}} = -25^\circ\text{C}$, $T_{\text{high}} = +85^\circ\text{C}$

 HT324A/B: $T_{\text{low}} = 0^\circ\text{C}$, $T_{\text{high}} = +70^\circ\text{C}$

 HT2902A: $T_{\text{low}} = -40^\circ\text{C}$, $T_{\text{high}} = +105^\circ\text{C}$

 HT2902B: $T_{\text{low}} = -40^\circ\text{C}$, $T_{\text{high}} = +125^\circ\text{C}$

HT2902B is qualified for automotive use.

 8. The input common mode voltage or either input signal voltage should not be allowed to go negative by more than 0.3 V. The upper end of the common mode voltage range is $V_{CC} - 1.7\text{ V}$, but either or both inputs can go to +32 V without damage, independent of the magnitude of V_{CC} .

Product parametric performance is indicated in the Electrical Characteristics for the listed test conditions, unless otherwise noted. Product performance may not be indicated by the Electrical Characteristics if operated under different conditions.

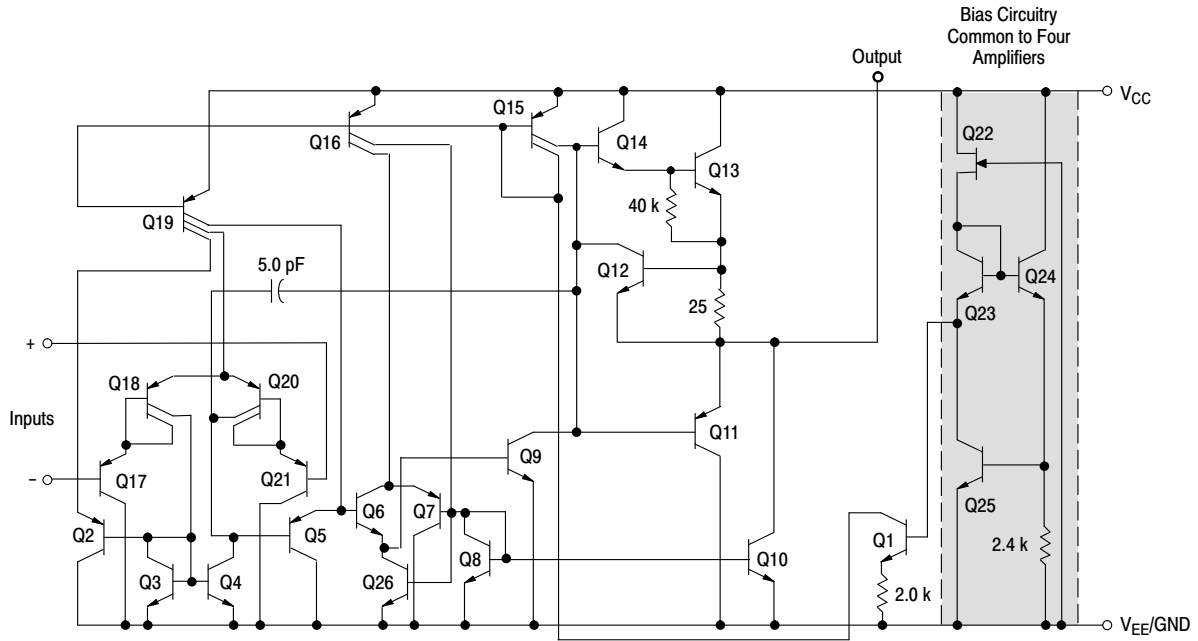

Figure 1. Representative Circuit Diagram
 (One-Fourth of Circuit Shown)

CIRCUIT DESCRIPTION

The HT324 series is made using four internally compensated, two-stage operational amplifiers. The first stage of each consists of differential input devices Q20 and Q18 with input buffer transistors Q21 and Q17 and the differential to single ended converter Q3 and Q4. The first stage performs not only the first stage gain function but also performs the level shifting and transconductance reduction functions. By reducing the transconductance, a smaller compensation capacitor (only 5.0 pF) can be employed, thus saving chip area. The transconductance reduction is accomplished by splitting the collectors of Q20 and Q18. Another feature of this input stage is that the input common mode range can include the negative supply or ground, in single supply operation, without saturating either the input devices or the differential to single-ended converter. The second stage consists of a standard current source load amplifier stage.

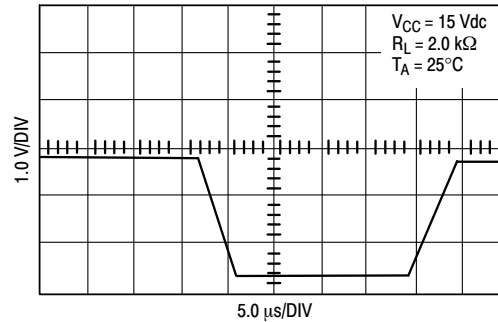

Figure 2. Large Signal Voltage Follower Response

Each amplifier is biased from an internal-voltage regulator which has a low temperature coefficient thus giving each amplifier good temperature characteristics as well as excellent power supply rejection.



Figure 3.

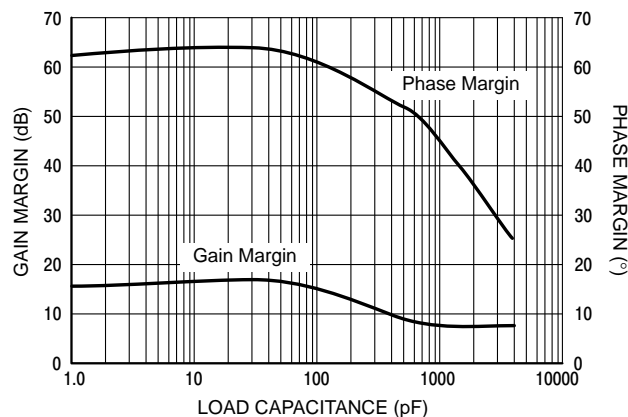

Figure 4. Gain and Phase Margin

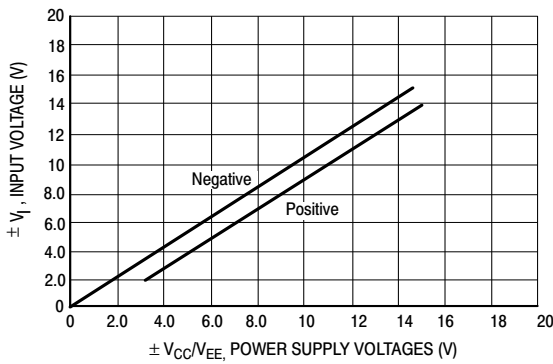

Figure 5. Input Voltage Range

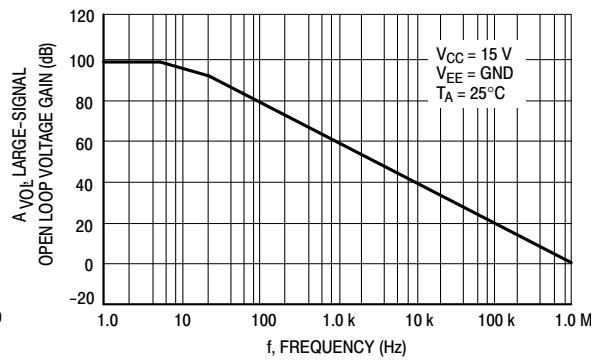

Figure 6. Open Loop Frequency

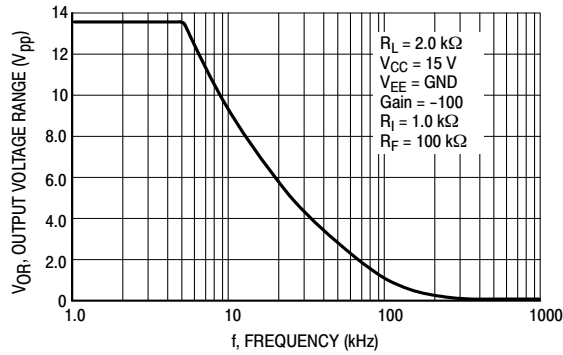

Figure 7. Large-Signal Frequency Response

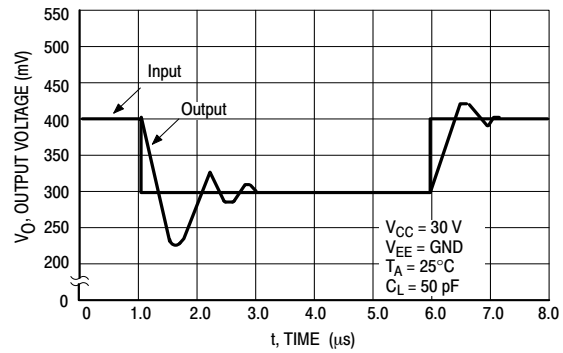

Figure 8. Small-Signal Voltage Follower Pulse Response (Noninverting)

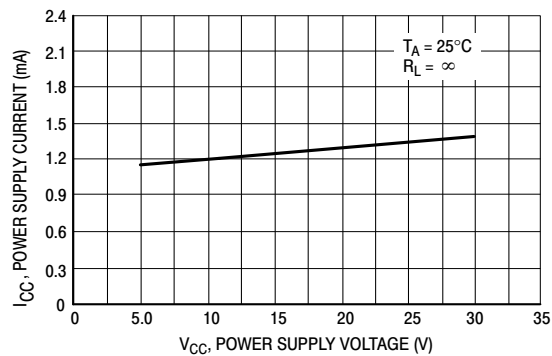

Figure 9. Power Supply Current versus Power Supply Voltage

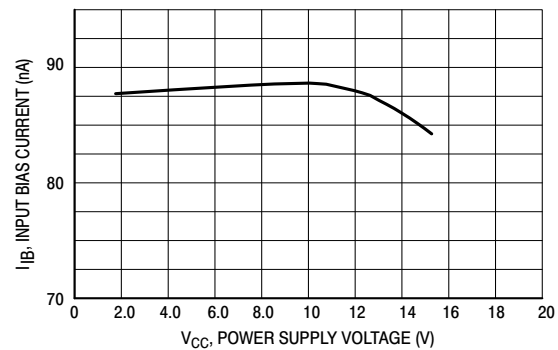

Figure 10. Input Bias Current versus Power Supply Voltage

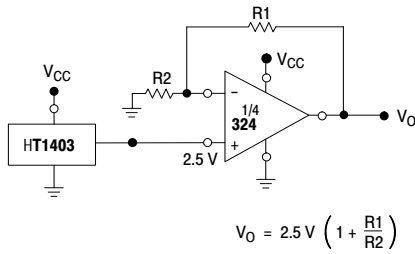

Figure 11. Voltage Reference

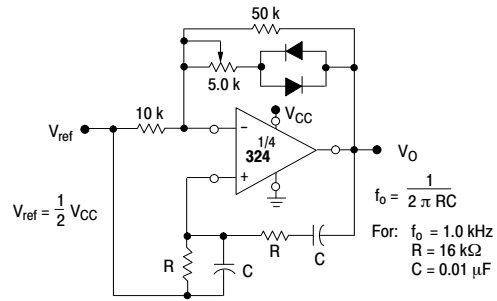

Figure 12. Wien Bridge Oscillator

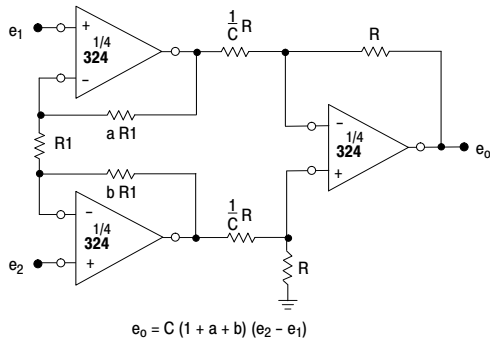

Figure 13. High Impedance Differential Amplifier

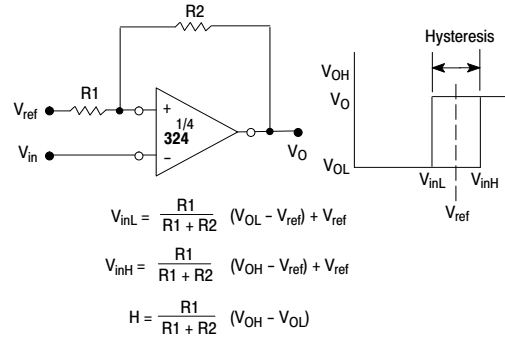

Figure 14. Comparator with Hysteresis

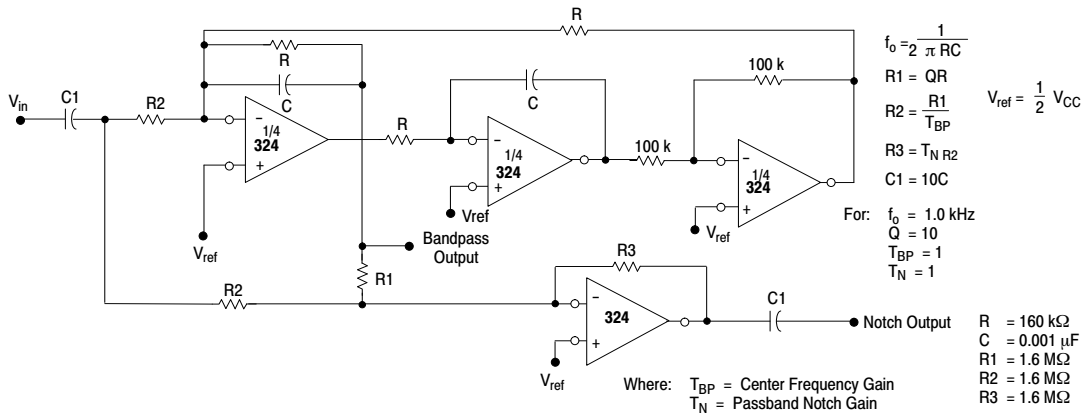
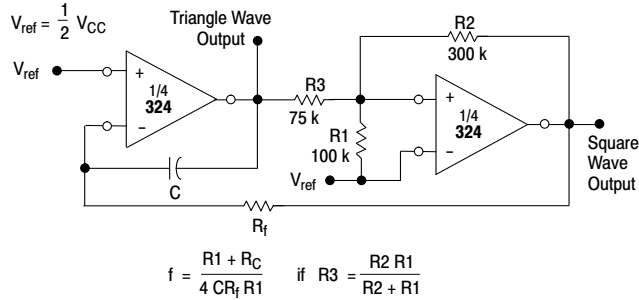
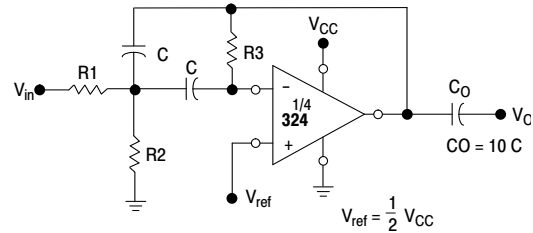

Figure 15. Bi-Quad Filter

Figure 16. Function Generator

Figure 17. Multiple Feedback Bandpass Filter

Given: f_0 = center frequency
 $A(f_0)$ = gain at center frequency

Choose value f_0, C

$$\text{Then: } R3 = \frac{Q}{\pi f_0 C}$$

$$R1 = \frac{R3}{2 A(f_0)}$$

$$R2 = \frac{R1 R3}{4Q^2 R1 - R3}$$

For less than 10% error from operational amplifier, $\frac{Q_0 f_0}{BW} < 0.1$

where f_0 and BW are expressed in Hz.

If source impedance varies, filter may be preceded with voltage follower buffer to stabilize filter parameters.

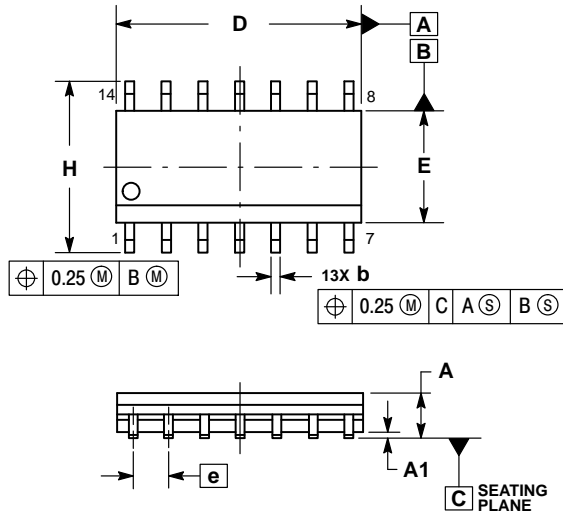
SOIC-14
 CASE 751A-03
 ISSUE K

NOTES:

1. DIMENSIONING AND TOLERANCING PER ASME Y14.5M, 1994.
2. CONTROLLING DIMENSION: MILLIMETERS.
3. DIMENSION b DOES NOT INCLUDE DAMBAR PROTRUSION. ALLOWABLE PROTRUSION SHALL BE 0.13 TOTAL IN EXCESS OF AT MAXIMUM MATERIAL CONDITION.
4. DIMENSIONS D AND E DO NOT INCLUDE MOLD PROTRUSIONS.
5. MAXIMUM MOLD PROTRUSION 0.15 PER SIDE.

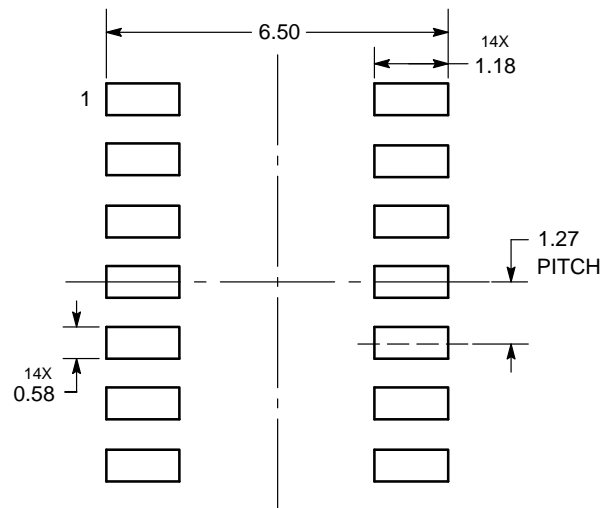
DIM	MILLIMETERS		INCHES	
	MIN	MAX	MIN	MAX
A	1.35	1.75	0.054	0.068
A1	0.10	0.25	0.004	0.010
A3	0.19	0.25	0.008	0.010
b	0.35	0.49	0.014	0.019
D	8.55	8.75	0.337	0.344
E	3.80	4.00	0.150	0.157
e	1.27 BSC		0.050 BSC	
H	5.80	6.20	0.228	0.244
h	0.25	0.50	0.010	0.019
L	0.40	1.25	0.016	0.049
M	0°	7°	0°	7°

SOLDERING FOOTPRINT*

DIMENSIONS: MILLIMETERS

*For additional information on our Pb-Free strategy and soldering details, please download the ON Semiconductor Soldering and Mounting Techniques Reference Manual, SOLDERRM/D.

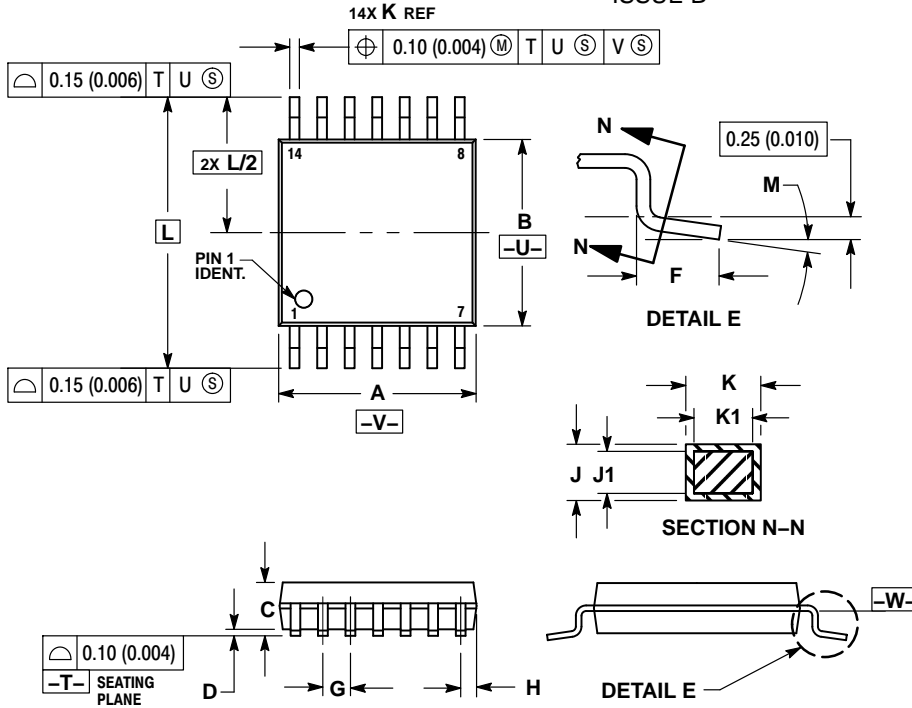
PACKAGE DIMENSIONS
TSSOP-14
CASE 948G
ISSUE B

NOTES:

1. DIMENSIONING AND TOLERANCING PER ANSI Y14.5M, 1982.
2. CONTROLLING DIMENSION: MILLIMETER.
3. DIMENSION A DOES NOT INCLUDE MOLD FLASH, PROTRUSIONS OR GATE BURRS. MOLD FLASH OR GATE BURRS SHALL NOT EXCEED 0.15 (0.006) PER SIDE.
4. DIMENSION B DOES NOT INCLUDE INTERLEAD FLASH OR PROTRUSION. INTERLEAD FLASH OR PROTRUSION SHALL NOT EXCEED 0.25 (0.010) PER SIDE.
5. DIMENSION K DOES NOT INCLUDE DAMBAR PROTRUSION. ALLOWABLE DAMBAR PROTRUSION SHALL BE 0.08 (0.003) TOTAL IN EXCESS OF THE K DIMENSION AT MAXIMUM MATERIAL CONDITION.
6. TERMINAL NUMBERS ARE SHOWN FOR REFERENCE ONLY.
7. DIMENSION A AND B ARE TO BE DETERMINED AT DATUM PLANE -W-.

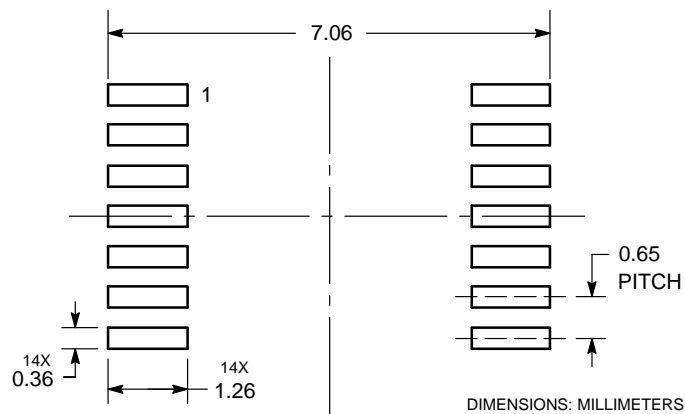
DIM	MILLIMETERS		INCHES	
	MIN	MAX	MIN	MAX
A	4.90	5.10	0.193	0.200
B	4.30	4.50	0.169	0.177
C	---	1.20	---	0.047
D	0.05	0.15	0.002	0.006
F	0.50	0.75	0.020	0.030
G	0.65 BSC		0.026 BSC	
H	0.50	0.60	0.020	0.024
J	0.09	0.20	0.004	0.008
J1	0.09	0.16	0.004	0.006
K	0.19	0.30	0.007	0.012
K1	0.19	0.25	0.007	0.010
L	6.40 BSC		0.252 BSC	
M	0°	8°	0°	8°

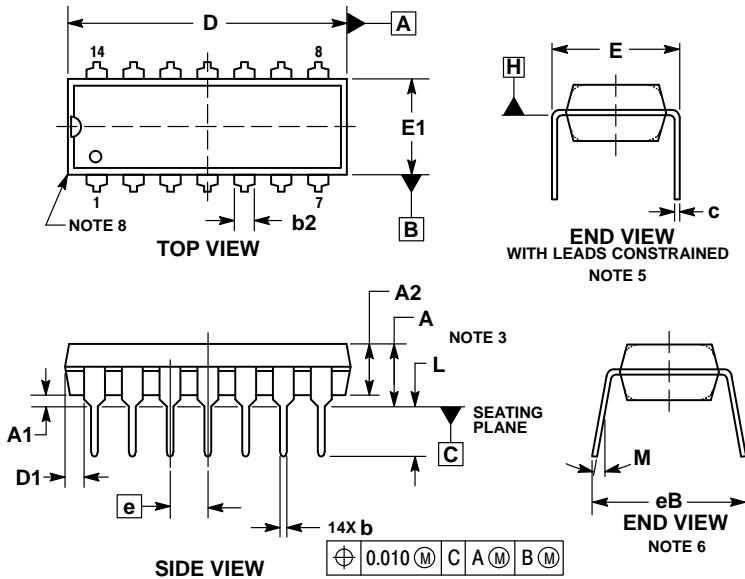
SOLDERING FOOTPRINT

PACKAGE DIMENSIONS
PDIP-14
 CASE 646-06
 ISSUE S

NOTES:

1. DIMENSIONING AND TOLERANCING PER ASME Y14.5M, 1994.
2. CONTROLLING DIMENSION: INCHES.
3. DIMENSIONS A, A1 AND L ARE MEASURED WITH THE PACKAGE SEATED IN JEDEC SEATING PLANE GAUGE GS-3.
4. DIMENSIONS D, D1 AND E1 DO NOT INCLUDE MOLD FLASH OR PROTRUSIONS. MOLD FLASH OR PROTRUSIONS ARE NOT TO EXCEED 0.10 INCH.
5. DIMENSION E IS MEASURED AT A POINT 0.015 BELOW DATUM PLANE H WITH THE LEADS CONSTRAINED PERPENDICULAR TO DATUM C.
6. DIMENSION eB IS MEASURED AT THE LEAD TIPS WITH THE LEADS UNCONSTRAINED.
7. DATUM PLANE H IS COINCIDENT WITH THE BOTTOM OF THE LEADS, WHERE THE LEADS EXIT THE BODY.
8. PACKAGE CONTOUR IS OPTIONAL (ROUNDED OR SQUARE CORNERS).

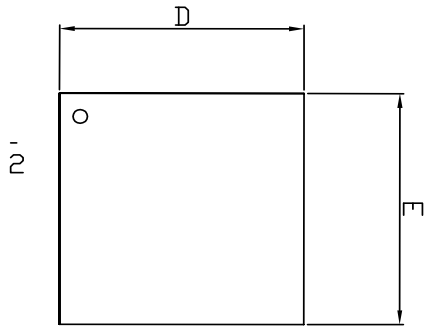
DIM	INCHES		MILLIMETERS	
	MIN	MAX	MIN	MAX
A	----	0.210	----	5.33
A1	0.015	----	0.38	----
A2	0.115	0.195	2.92	4.95
b	0.014	0.022	0.35	0.56
b2	0.060 TYP		1.52 TYP	
C	0.008	0.014	0.20	0.36
D	0.735	0.775	18.67	19.69
D1	0.005	----	0.13	----
E	0.300	0.325	7.62	8.26
E1	0.240	0.280	6.10	7.11
e	0.100 BSC		2.54 BSC	
eB	----	0.430	----	10.92
L	0.115	0.150	2.92	3.81
M	----	10°	----	10°

QFN16L(3*3*0.5)

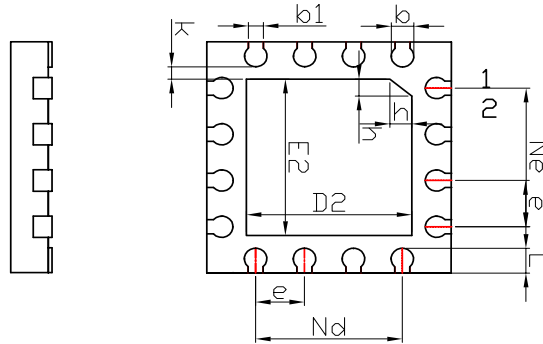
TOP VIEW



BOTTOM VIEW

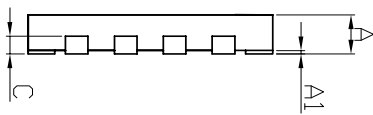

SIDE VIEW

Symbol	Dimensions In Millimeters		
	Min	Nom	Max
A	0.45	0.50	0.55
A1	0	0.02	0.05
b	0.23	0.28	0.33
b1	0.20REF		
c	0.152REF		
D	2.90	3.00	3.10
D2	1.80	1.90	2.00
e	0.50BSC		
Ne	1.50BSC		
Nd	1.50BSC		
E	2.90	3.00	3.10
E2	1.80	1.90	2.00
L	0.25	0.30	0.35
K	0.20	0.25	0.30
h	0.20	0.25	0.30