

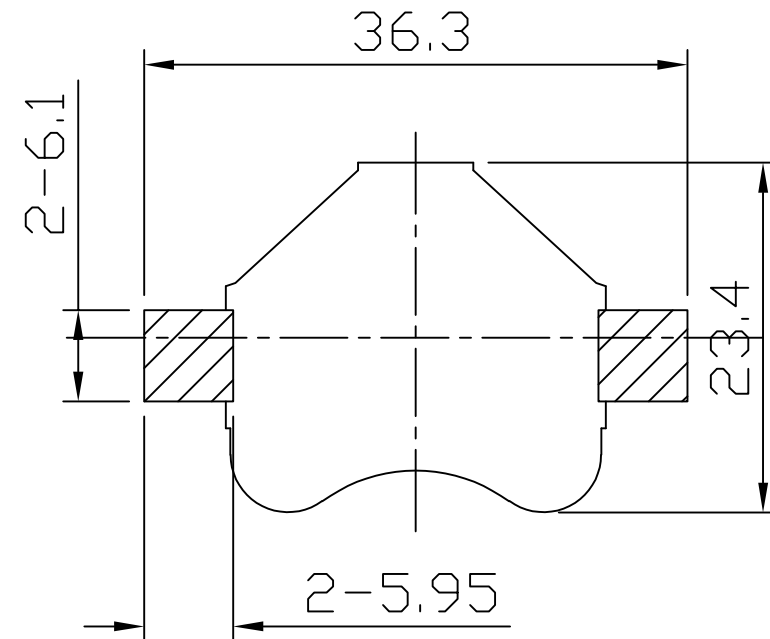

REV.	ECN NO.	REVISED	DATE

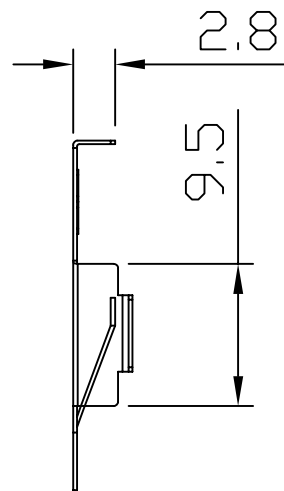
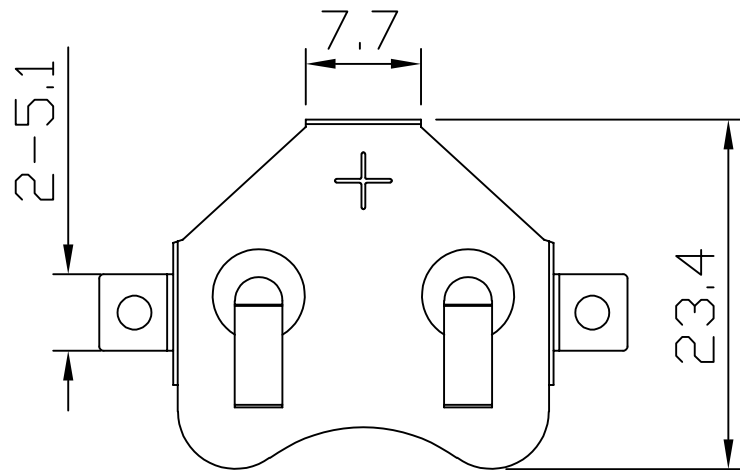

PCB Layout Diagram  
Top View

工程部  
2021-11-09  
H. WANG

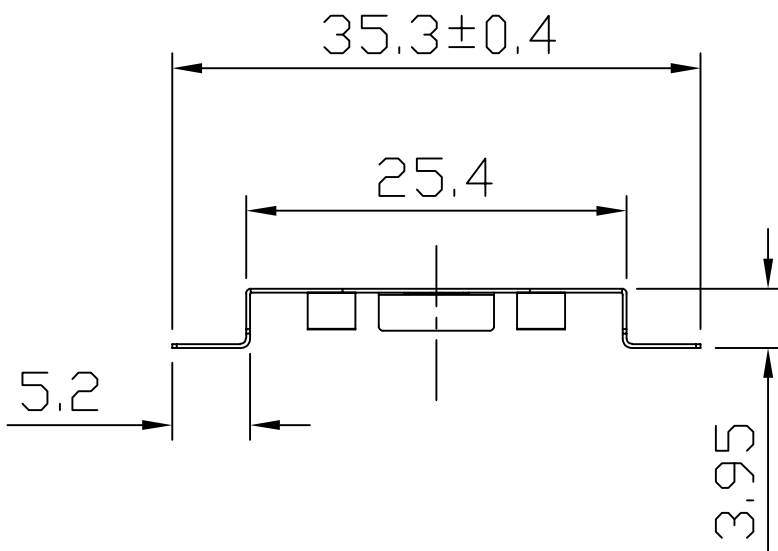

UNLESS OTHERWISE SPECIFIED TOLERANCES		<b>MYOUNG 美用</b> <a href="http://www.meiyangdz.com">www.meiyangdz.com</a>	
DECIMALS: X :±0.30 X.X :±0.25 X.XX :±0.20 X.XXX :±0.10	ANGLES: X :±1° X.X :±0.5°	DSND YangFeng	DATE 2021-11-09
		CHKD ZhouRuicai	DATE 2021-11-09
		APVD XueShunyong	DATE 2021-11-09
		WEIGHT: 9	SCALE: 2:1
		SHEET 1 OF 1	SIZE: A4
		UNIT: mm	VIEW:
		REV.: A/0	OBJECT: MY
		TITLE: 电池扣CR2430-W Ni SMT	
		PART NO.: MY-2430-06	
		DRAW NO.:WD-CP-0179	

1	TERMINAL(+)	1	C5191, T=0.25mm	Ni-Plating
NO.	PART NAME	Q'TY	MATERIAL	PLATING & COLOR

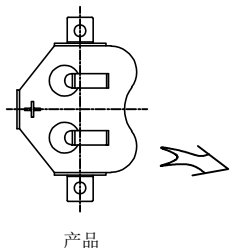

产品

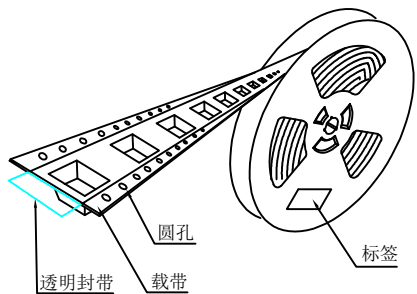

圆孔

透明封带

载带

标签

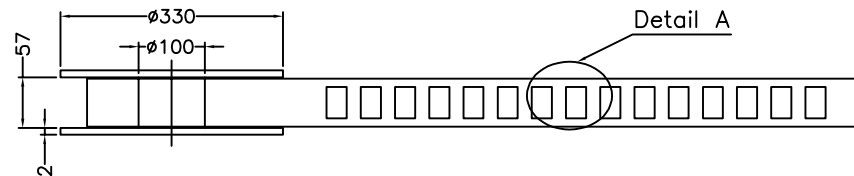

Detail A

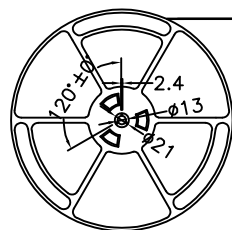

出料方向

余留封带长: 280 MIN  
载带与封带剥离  
剥离角度: 165° -180°  
剥离强度: 0.1-1.0N

10空穴

共封装 400 只产品

280MIN

末端留空穴载带

前端留空穴载带

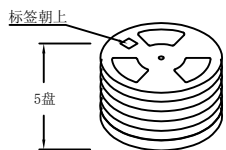

标签朝上

5盘

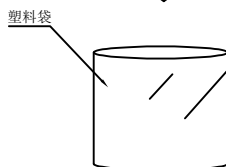

塑料袋

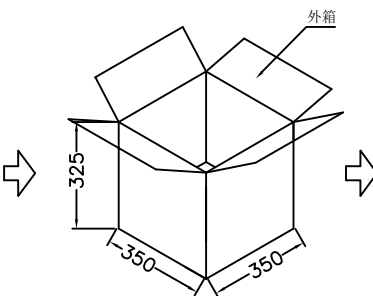

外箱

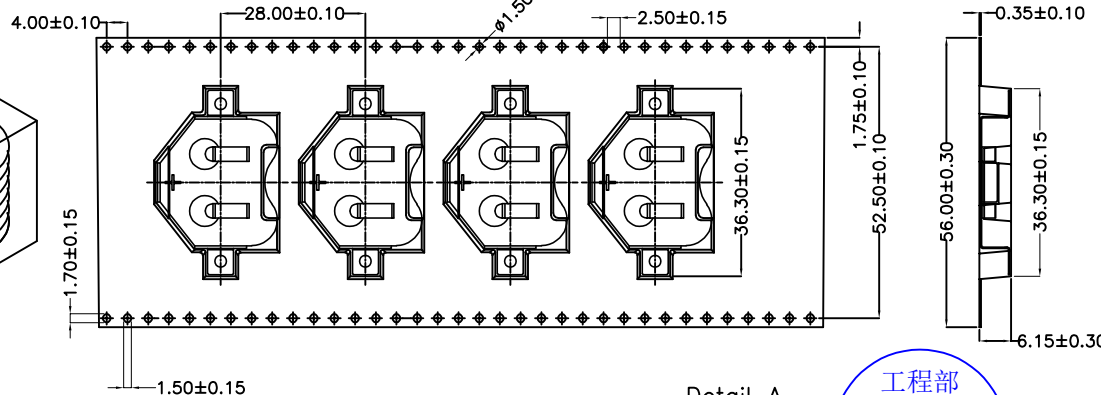
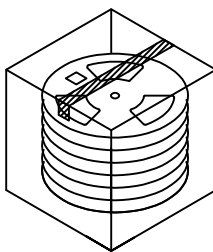

Detail A



技术要求:

1. 圆孔十个孔距离累计允许公差为±0.2mm
2. 带长250mm内容许弯曲度1mm
3. 材料厚度以在载带边缘测量为准
4. 所有尺寸定义依循EIA-481-C系准则定义之
5. 材料: 黑色PS T=0.35mm
6. 所有卷轮为灰蓝挖空旋转塑胶卷轮
7. 整模成型长度: 11.76M,
8. 非指明公差范围为: ±0.1mm; 超过250mm不计算累计误差
9. 型腔外形凡未标明处倒角R为0.2-0.3; 拔模斜度未标注的为3° 以下

包装信息:

- 1、每卷盘装产品 400 只, 卷盘外侧贴相关标签;
- 2、每 5 卷盘放在一个塑料袋中;
- 3、每外箱装5盘, 产品总数: 2000 只;
- 4、外箱上下用胶纸封成“工”字;
- 5、净重: 2.8 KG, 毛重: 5.8 KG.

UNLESS OTHERWISE SPECIFIED TOLERANCES		<b>MYOUNG 美阳</b> www.meiyangdz.com	
DECIMALS: X : ±*** X.X : ±*** X.XX : ±*** X.XXX : ±***	ANGLES: X : ±*** X.X : ±***	DSND YangFeng	DATE 2021-11-18
		CHKD ZhouRuicai	DATE 2021-11-18
		APVD XueShun Yong	DATE 2021-11-18
WEIGHT:		SCALE:	VIEW:
SHEET 1 OF 1		SIZE: A4	REV.: A/0
		UNIT: mm	OBJECT: MY
		TITLE: 电池扣CR2450-W SMT 卷装	
		PART NO.: MY-2450-01-R	
		DRAW NO.: MY-BD-0019	