

RoHS 2.0

REV.	ECN NO.	DESCRIPTION	DATE	DESIGN
A0		新版发行	20.04.09	Yang
A1		重新核对图面	21.01.07	LiHui

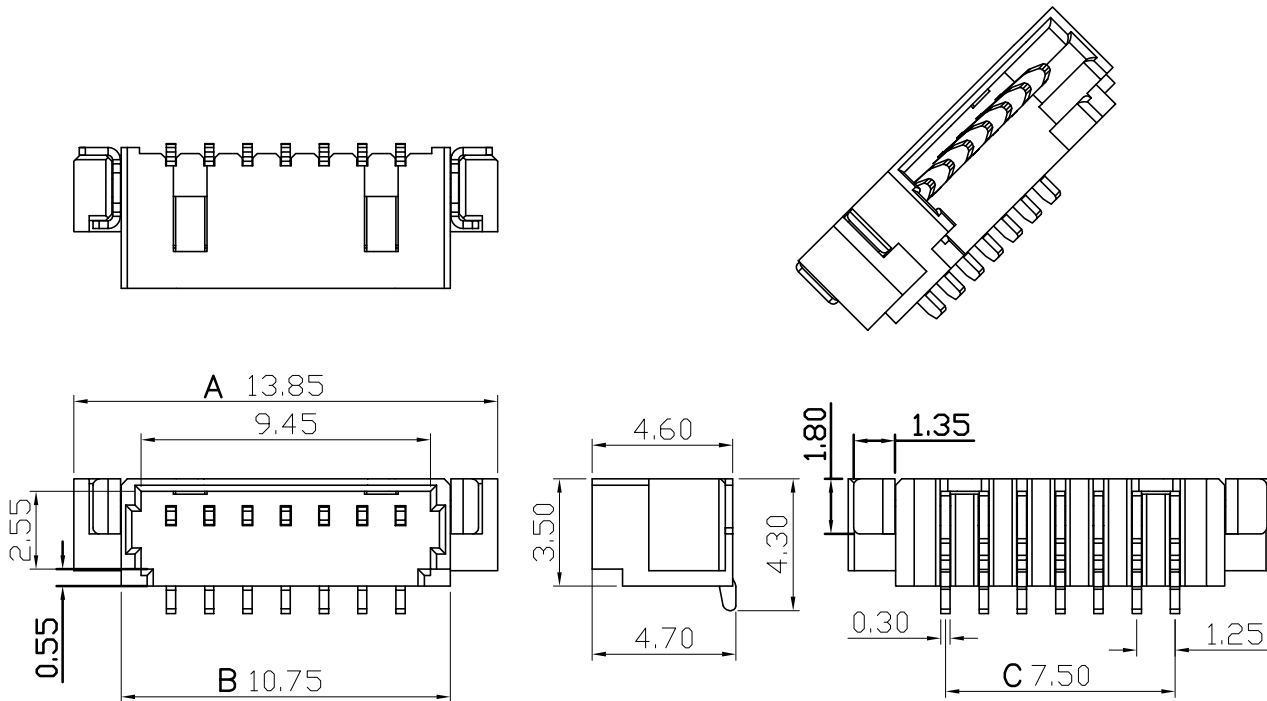

PIN数	A±0.1	B±0.1	C±0.1
2P	7.60	4.50	1.25
3P	8.85	5.75	2.50
4P	10.10	7.00	3.75
5P	11.35	8.25	5.00
6P	12.60	9.50	6.25
7P	13.85	10.75	7.50

Specifications:

Rated Voltage : 125V AC/DC

Rated Current : 1A AC,DC

Withstand Voltage : 200V AC/minute

Contact Resistance : 50mΩ(MAX.)

Insulation Resistance : 100MΩ(MIN.)

Storage Temperature Range: -40°C~+85°C;

Operation Temperature Range: -25°C~+70°C;

3	插片	黄铜H65	镀镍锡	
2	插针	黄铜H65	镀镍锡	
1	基座	LCP	本色	
序号	品名	材质	电镀/颜色	备注

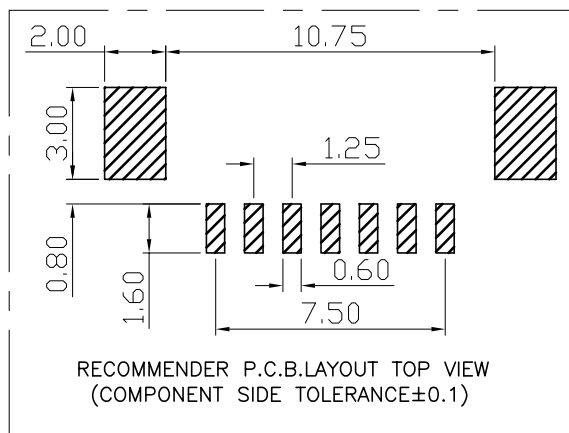

深圳市虹成电子有限公司

UNLESS OTHERWISE, GENERAL TOLERANCE: X. xxx ±0.05 X. xx ±0.15 X. x ±0.25	NAME: 针座1.25立贴7P		P/N: HCZZ0015-7		
	无缺口		DWG NO:		
THIRD ANGLE PROJECTION 	UNIT:	SCALE:	SIZE:	SHEET:	REV.
	MM	1:1	A4	1/1	A1
DRAWN:		CHECKED:		APPROVED:	

ANGULAR:
X. xx° ±1°
X. x° ±3°
X. ° ±5°