

岱煒科技股份有限公司
ASSEM TECHNOLOGY CO.,LTD.
SPECIFICATION FOR APPROVAL

PART NAME : 0.35PH 0.6H Ultra-Slim BTB

ASG7SXX10(Socket)

PART NO. : ASG8HXX10 (Header)

APP. DATE : 2015.11.16

MANUFACTURER SIGNATURE

TABLE OF CONTENT

- I. SPECIFICATION OF PRODUCT
- II. MATERIAL REFERENCE TABLE
- III. MATERIAL CERTIFICATE OF HOUSING
- IV. MATERIAL CERTIFICATE OF TERMINAL
- V. ENGINEERING DRAWING OF PRODUCT

PRODUCT NAME: 0.35mm pitch mating height 0.6mm with power pin Ultra-Slim BTB Connector

REV: A

ISSUE DATE: 2015-03-01

PAGE: 1

ASSEM TECHNOLOGY 岱煒科技股份有限公司

SPECIFICATION OF PRODUCT

0.35mm pitch mating height 0.6mm with power pin Ultra-Slim Board-to-Board Connector

1. Scope:

This specification covers the requirements of product performance, and test methods provisions of 0.35mm pitch mating height 0.6mm with power pin Ultra-Slim Board-to-Board connector.

2. Applicable documents:

The following document from a part of this specification to the extent specified herein. In the event of conflict between the requirements of this specification and the product drawing, the product drawing shall take precedence. In the event of conflict between the requirements of this specification and the referenced documents, this specification shall take precedence.

3. Requirements:

3.1. Materials:

Signal Terminal (Socket /Header): Copper Alloy. Au Plating over nickel.

Power Terminal (Socket/Header): Copper Alloy. Au Plating over nickel.

Housing: Heat Resistance Plastic(UL 94V-0) ,Black.

4. Manufacture Place :

No.17, Minquan ST.,Tucheng Dist.,New Taipei City 23679,TAIWAN

5. Electrical Performance:

No.	Items	Requirements	Test Procedures
5.1	Rated current	Signal terminal 0.3A per pin (All pins can carry Max.5A) Power terminal 3A Max. per pin	-
5.2	Rated voltage	30V AC/DC	-
5.3	Breakdown Voltage	150V AC for 1minute (Initial stage)	In accordance with method of JIS C5402. Test with 1mA current and 250VDC for 1 minute
5.4	Insulation resistance	1000MΩ Min.(initial)	

PRODUCT NAME: 0.35mm pitch mating height 0.6mm with power pin Ultra-Slim BTB Connector

REV: A

ISSUE DATE: 2015-03-01

PAGE: 2

ASSEM TECHNOLOGY 岱煒科技股份有限公司

5.5	Contact resistance	Signal terminal 90mΩ Max. Power terminal 30mΩ Max.	
-----	--------------------	---	--

6. Environmental Performance:

No.	Items	Requirements	Test Procedures
6.1	Ambient Temperature	-55°C ~ 85°C	No freezing or condensation
6.2	Storage Temperature	-55°C ~ 85°C ..(Products only) -40°C ~ 50°C (Packaging structure)	No freezing or condensation
6.3	Thermal shock	5 cycles Contact resistance. Signal terminal : 90mΩ Max. Power terminal: 30mΩ Max. Insulation resistance 100MΩ Min.	In accordance with method MIL-STD-202G method 107G. -55±3°C (30min) → 25±3°C (5min) → 85±3°C (30min) → 25±3°C (5min) → -55±3°C (30min) for 5 cycles.
6.4	Humidity	Signal terminal : 90mΩ Max. Power terminal: 30mΩ Max. Insulation resistance 100MΩ Min.	In accordance with MIL-STD-1344A method 1002 The specimens shall be placed in a chamber and subjected to a relative humidity of 90 to 95 % and temperature of 40±2°C for 120 hours
6.5	Salt spray	Signal terminal : 90mΩ Max. Power terminal: 30mΩ Max. Insulation resistance 100MΩ Min.	In accordance with method MIL-STD-1344A method 1001. The specimens subjected to the chamber temperature of 35±2°C exposure to a salt spray from 5±1% solution for 24 hours.
6.6	H ₂ S resistance	Signal terminal : 90mΩ Max. Power terminal: 30mΩ Max.	Bath temperature 40±2°C Gas concentration 3±1ppm Humidity 75 to 80%R.H. for 48hours.

PRODUCT NAME: 0.35mm pitch mating height 0.6mm with power pin Ultra-Slim BTB Connector

REV: A

ISSUE DATE: 2015-03-01

PAGE: 3

ASSEM TECHNOLOGY 岱煒科技股份有限公司

7. Mechanical Performance:

No.	Items	Requirements	Test Procedures
7.1	Insertion force	1.3 Nf. max. per pin	Mate applicable header or socket at the speed of 5±1 mm/min.
7.2	Withdrawal force	0.165 Nf. min. per pin	Mate applicable header or socket at the speed of 5±1 mm/min.
7.3	Vibration	Appearance no damage, loose part nor crack. Signal terminal : 90mΩ Max. Power terminal: 30mΩ Max. Discontinuity : 1μs MAX.	In accordance with method MIL-STD-202G method 201 condition A, all contacts shall be connected in series and DC 5mA shall be applied. Wave form : Sine wave. Frequency : 10~55~10Hz/1min. Amplitude : 1.5mm. Orientation : X,Y,Z (3 axes). Duration : 2hrs./axis.
7.4	Shock	Appearance no damage, loose part nor crack. Signal terminal : 90mΩ Max. Power terminal: 30mΩ Max. Discontinuity : 1μs MAX.	In accordance with method MIL-STD-202G method 213B condition A. DC 100mA shall be applied. MAX acceleration: 50G. Wave form : Half sine wave. Orientation : X,Y,Z (3 axes). Duration : 11ms./axis. Times: 3 times/axis.
7.5	Resistance to soldering heat	No loose contacts nor damage	1. Hand soldering: Soldering time: 3 ± 0.5 second. Solder temperature: 350 ± 5°C. 2. Reflow: In accordance with method MIL-STD-202 method 210 condition K.
7.6	Durability	Signal terminal : 90mΩ Max. Power terminal: 30mΩ Max.	Mate applicable header or socket , insert and withdrawal at the speed rate of 5 ± 1 mm/min. up to 30 times

PRODUCT NAME: 0.35mm pitch mating height 0.6mm with power pin Ultra-Slim BTB Connector

REV: A

ISSUE DATE: 2015-03-01

PAGE: 4

8. RECOMMENDED IR REFLOW PROFILE

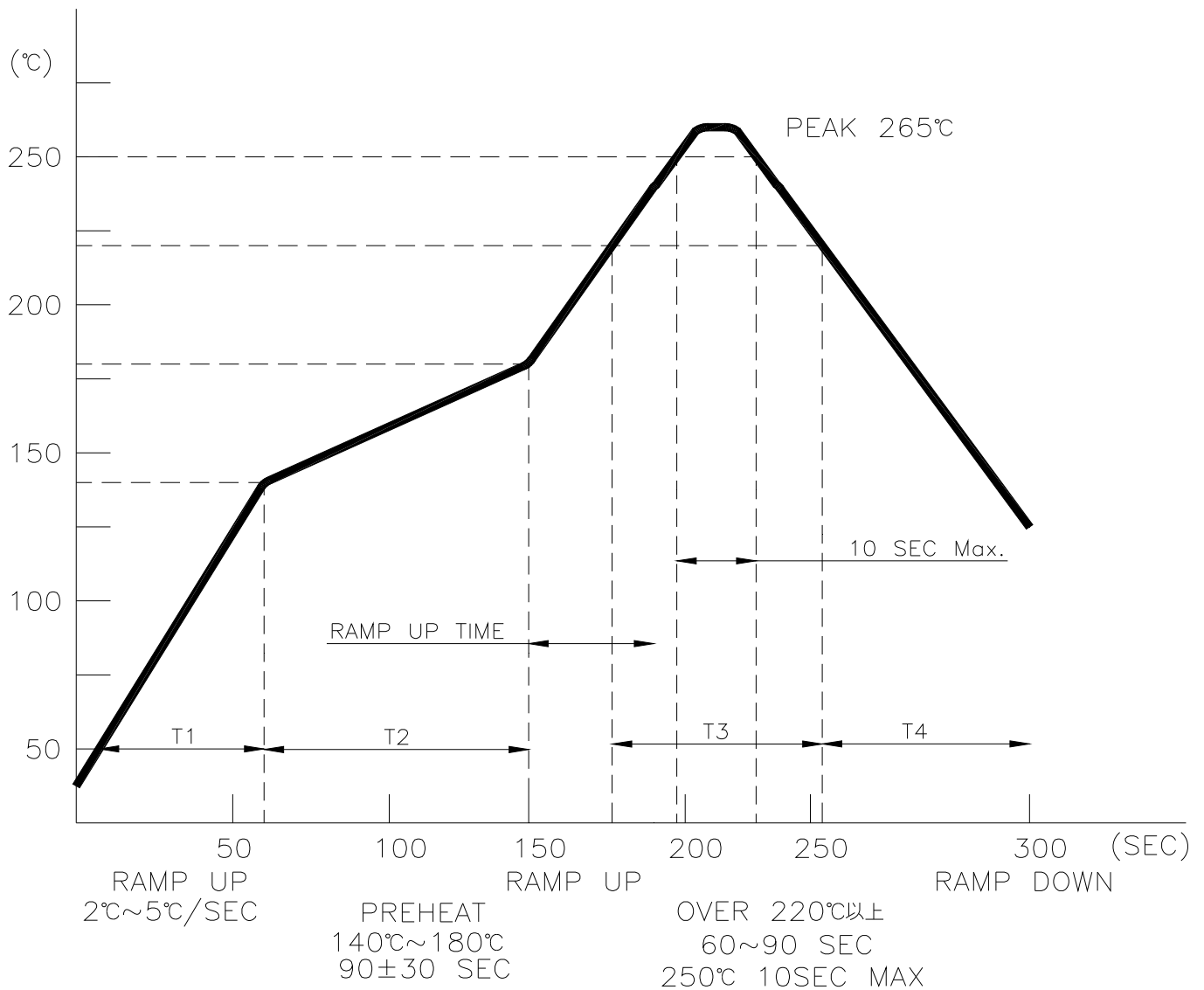

T1:	Temperature Ramp Up Rate	2°C~5°C/SEC
T2:	Preheat: 140°C~180°C	90±30 SEC
T3:	Time Over 220°C	60~90 SEC
T4:	Ramp Down Rate During Cooling	4°C~7°C/SEC
	Peak Temperature	265°C Max

PRODUCT NAME: 0.35mm pitch mating height 0.6mm with power pin Ultra-Slim BTB Connector

REV: A

ISSUE DATE: 2015-03-01

PAGE: 5

ASSEM TECHNOLOGY 岱煒科技股份有限公司

II. MATERIAL REFERENCE TABLE

Parts Name	General Name	Model No.	Heat Resistance Level	UL Card No.
Housing	LCP	E463i	UL94V-0	E106764
Socket Terminal	Phosphor Borne	C5210R-EH	—	—
Header Terminal	Phosphor Borne	C5191-EH	---	---
Socket Power Terminal	Phosphor Borne	C5191-EH	---	---
Header Power Terminal	Phosphor Borne	C5191-EH	---	---

PRODUCT NAME: 0.35mm pitch mating height 0.6mm with power pin Ultra-Slim BTB Connector

REV: A

ISSUE DATE: 2015-03-01

PAGE: 6

ASSEM TECHNOLOGY 岱煒科技股份有限公司

III. MATERIAL CERTIFICATE OF HOUSING

表 1-1 一般物性 (ISO)

项目	单位	测试方法	标准, SMT 对应
			E463 i
			低翘曲性, 低异向性
颜色			VF2201/BK210P/BK225P
ISO (JIS) 材质表示		ISO11469 (JIS K6999)	>LCP-(MD+GF) 40<
密度	g/cm ³	ISO 1183	1.72
吸水率 (23°C、水中 24 小时)	%	ISO 62	0.02
拉伸强度	MPa	ASTM D638	80
拉伸率	%	ASTM D638	1.6
弯曲强度	MPa	ISO 178	130
弯曲模量	MPa	ISO 178	10,600
弯曲应变	%	ISO 178	3.1
简支梁冲击强度 (有缺口)	kJ/m ²	ISO 179/1eA	5
负荷变形温度 (1.8MPa)	°C	ISO 75-1,2	235
负荷变形温度 (0.45MPa)	°C	ISO 75-1,2	270
绝缘破坏强度 (1mmt)	kV/mm	IEC 60243-1	44
绝缘破坏强度 (3mmt)	kV/mm	IEC 60243-1	22
体积电阻率	Ω·cm	IEC 60093	1 × 10 ¹⁶
体积电阻率 (本公司方法)	Ω·cm		-
介电损耗系数 (1kHz)		IEC 60250	4.5
介电损耗系数 (1MHz)		IEC 60250	3.9
介电损耗角正切 (1kHz)		IEC 60250	0.02
介电损耗角正切 (1MHz)		IEC 60250	0.03
耐导电径迹	V	IEC 60112	200
耐电弧性	s		182
成型收缩率 (80×80×1mmt、流动方向、注射压力 60MPa)	%	我公司规格	0.09
成型收缩率 (80×80×1mmt、垂直方向、注射压力 60MPa)	%	我公司规格	0.5
成型收缩率 (80×80×1mmt、流动方向、注射压力 79MPa)	%	我公司规格	-
成型收缩率 (80×80×1mmt、垂直方向、注射压力 79MPa)	%	我公司规格	-
洛氏硬度	M(Scale)	ISO2039-2	45
阻燃性		UL94	V-0
UL 发行的黄卡			E106764
「出口贸易管理法令」的该当项目番号			附表 1 第 16 项

以上数值为材料的代表性测试值、并非该规格材料的最低值。

PRODUCT NAME: 0.35mm pitch mating height 0.6mm with power pin Ultra-Slim BTB Connector		
REV: A	ISSUE DATE: 2015-03-01	PAGE: 7

ASSEM TECHNOLOGY 岱煒科技股份有限公司

MATERIAL CERTIFICATE OF SOCKET TERMINAL

P.002/003

(FAX)

2013/05/28 08:55 mono

試 験 成 績 書

INSPECTION CERTIFICATE

J X 日 敏 日 石 金 属 株 式 会 社 倉 見 工 場
KURAMI WORKS, JX NIPPON MINING & METALS CORPORATION

需要家
CUSTOMER
接 先 台湾日敏金属
MESSRS.
製品名 C5210R-EH (HP)
PRODUCTS
寸法 0.08 X 150Z X L
SIZE
規 格
SPECIFICATION

発 行 日 2013年02月06日
DATE OF ISSUE
納 品 番 号 42984
DELIVERY SHRET NO.
注 文 番 号 TLC12-647
CONTRACT NO.
オ ー ダ ー 番 号 01
ORDER NO.

0005 神奈川県高座郡寒川町倉見3番地
3 KURAMI, SAMUKAWA-MACHI, KOBUZA-GUN,
KANAGAWA-KEN 〒253-0101
TEL.0467-75-0611

品質保証課長
MANAGER OF QUALITY
ASSURANCE SECTION

Y. Oaei

化学成分
CHEMICAL COMPOSITIONS

規 格 SPECIFICATION	Zn %	Sn %	P %	Fe %	Pb %	Cu+Sn+P %												質 量 MASS (KG)	
製造番号 MIN		7.0	0.03			99.7													
LOT NO. MAX	0.20	9.0	0.35	0.10	0.02														
80347	0.01	7.68	0.12	0.001	0.002	99.90													1,234.00

機械的および物理的性質
MECHANICAL AND PHYSICAL PROPERTIES

規 格 SPECIFICATION	引張強さ TENSILE STRENGTH N/mm ²	伸び: ASTM ELONGATION (ASTM) %	耐 力 PROOF STRESS N/mm ²	硬 さ HARDNESS HV	90°曲試験(1) 90° BEND TEST (L)	90°曲試験(2) 90° BEND TEST (T)													
製造番号 MIN	685	11.0	590	210															寸法検査 DIMENSIONAL INSPECTIONS
LOT NO. MAX	785			260	R=TX0.5	R=TX1.0													表面検査 SURFACE INSPECTIONS
80347	748	19.0	711	240	GOOD	GOOD													備考 REMARKS.

この製品は品質管理計画に基づき製造され、検査・試験を行ない、規格に合格したことを証明する。
WE HEREBY CERTIFY THAT THE PRODUCTS DESCRIBED HEREIN HAVE BEEN MANUFACTURED, INSPECTED AND TESTED IN ACCORDANCE WITH THE SPECIFICATION AND Q. C. PROGRAM.

PRODUCT NAME: 0.35mm pitch mating height 0.6mm with power pin Ultra-Slim BTB Connector		
REV: A	ISSUE DATE: 2015-03-01	PAGE: 10

CUSTOMER

REV.	DCN/ECN	DESCRIPTION	DR.	DATE	APPD.

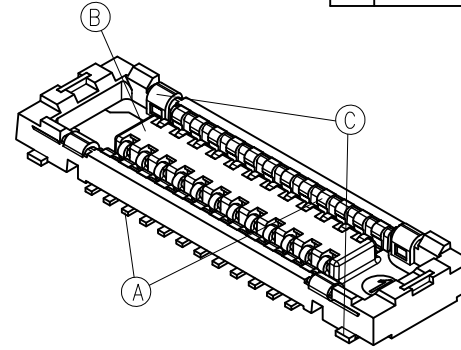
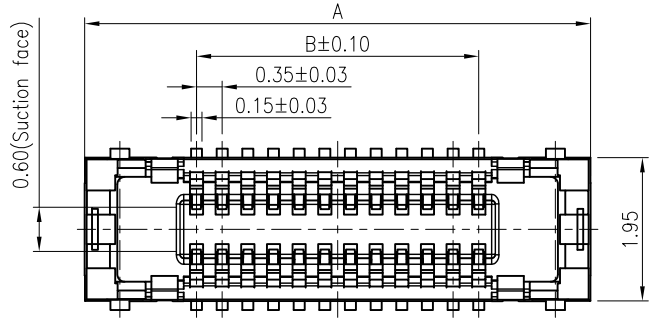

※ : Mass Production

No. of contacts	Dimension		
	A	B	C
※ 10	4.45	1.40	3.45
※ 12	4.80	1.75	3.80
16	5.50	2.45	4.50
20	6.20	3.15	5.20
※ 24	6.90	3.85	5.90
※ 30	7.95	4.90	6.95
※ 34	8.65	5.60	7.65
※ 40	9.70	6.65	8.70
※ 44	10.40	7.35	9.40
※ 50	11.45	8.40	10.45
60	13.20	10.15	12.20

Metal mask thickness: when 100 um
 Signal terminal opening retlo:70%
 Poewr terminal opening retlo:100%

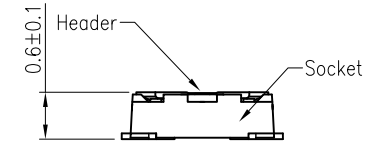
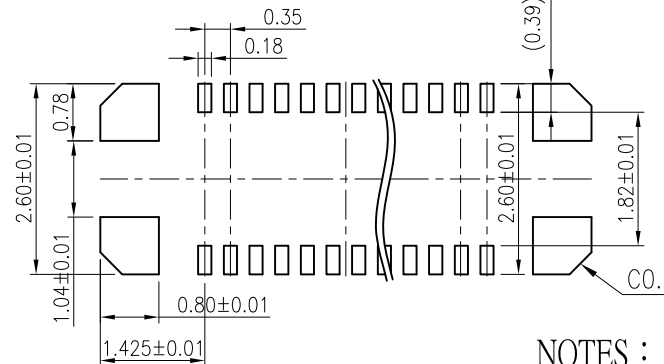
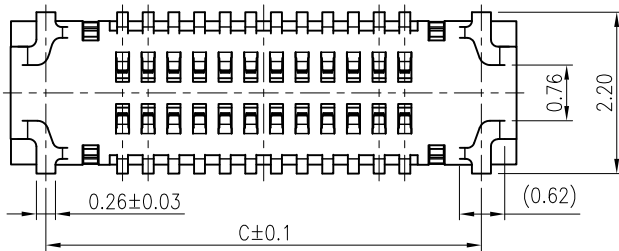
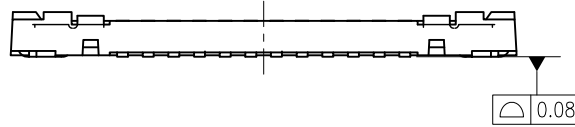

Matting drawing

NOTES :

1. Part No. : ASG 7S XX 10

No. OF SERIES 7S : SOCKET Contacts No.

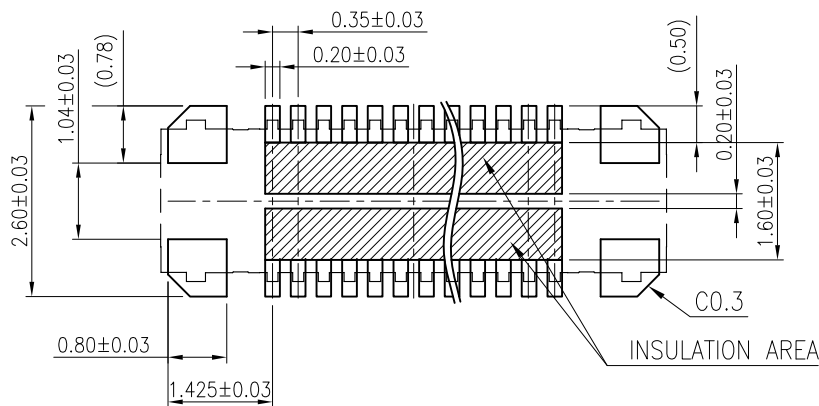

Recommended PC board pattern
(mounting pad layout)

①	POWER PIN	2	COPPER ALLOY	GOLD	-
②	HOUSING	1	HIGH TEMP.PLASTIC	BLACK	UL94-V0
③	TERMINAL	-	COPPER ALLOY	GOLD	-
ITEM	DESCRIPTIONS	QTY.	MATERIAL	FINISH	REMARKS
General tolerance		P / N		TITLE	
DIMENSION		ASG7SXX10		0.35mm Pitch BOARD TO BOARD MATED HEIGHT 0.60mm SOCKET CONNECTOR	
ANGLES		Original Date		D / N	
. ± 0.4		2015/01/06		ASG7SXX10	
.X ± 0.3		DR. PHIL		SCALE UNIT REV. SHEET	
.XX ± 0.15		CHK. JERRY		10:1 mm B 1/1	
.XXX ± 0.1		APPD. STING		ATC ASSEM TECHNOLOGY CO., LTD.	

CUSTOMER

REV.	DCN/ECN	DESCRIPTION	DR.	DATE	APPD.

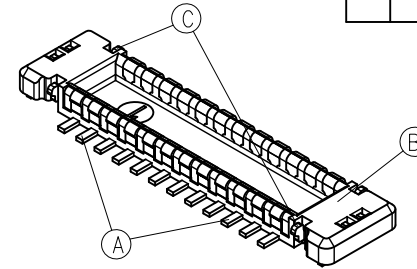
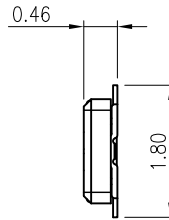
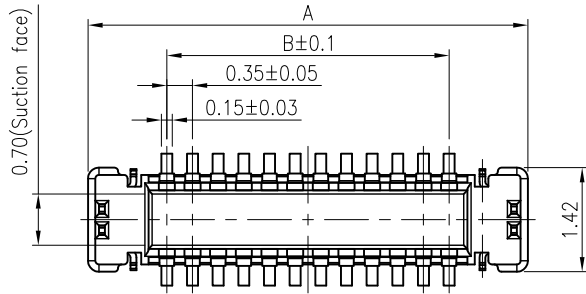

※ : Mass Production

No. of contacts	Dimension		
	A	B	C
※ 10	3.55	1.40	3.17
※ 12	3.90	1.75	3.52
※ 16	4.60	2.45	4.22
※ 20	5.30	3.15	4.92
※ 24	6.00	3.85	5.62
※ 30	7.05	4.90	6.67
※ 34	7.75	5.60	7.37
※ 40	8.80	6.65	8.42
※ 44	9.50	7.35	9.12
※ 50	10.55	8.40	10.17
※ 60	12.30	10.15	11.92

Metal mask thickness: when 100 um
Signal terminal opening retlo:70%
Poewr terminal opening retlo:77%

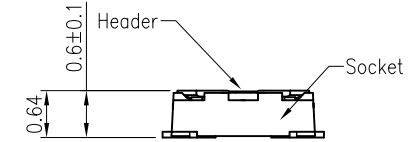
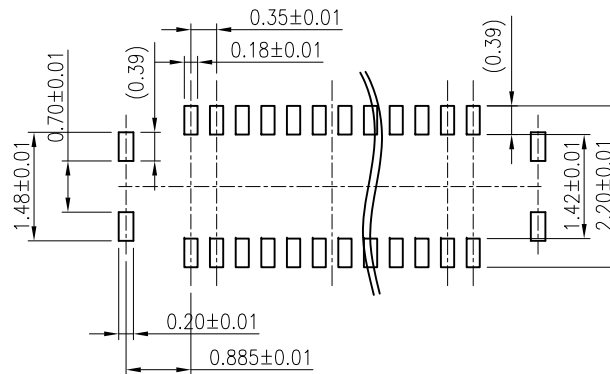
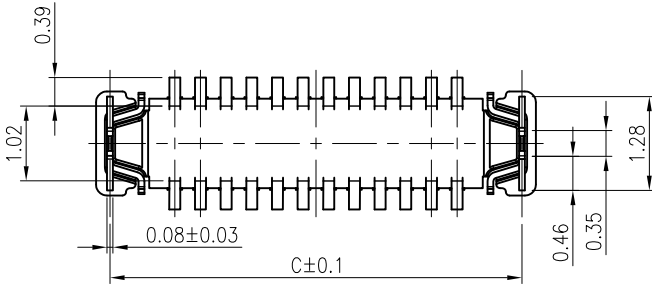
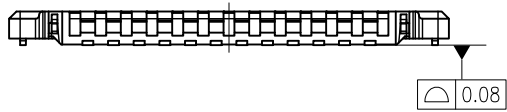

Matting drawing

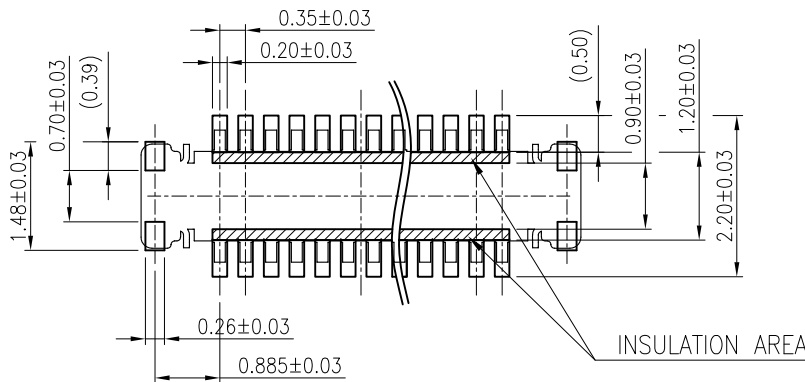

Recommended PC board pattern
(mounting pad layout)

NOTES : 1. Part No. : ASG 8H XX 10

No. OF SERIES
8H : HEADER Contacts No.

Ⓒ	POWER PIN	2	COPPER ALLOY	GOLD	-
Ⓑ	HOUSING	1	HIGH TEMP.PLASTIC	BLACK	UL94-V0
Ⓐ	TERMINAL	-	COPPER ALLOY	GOLD	-
ITEM	DESCRIPTIONS	QTY.	MATERIAL	FINISH	REMARKS
General tolerance		P / N		TITLE	
DIMENSION		ASG8HXX10		0.35mm Pitch BOARD TO BOARD MATED HEIGHT 0.60mm HEADER CONNECTOR	
ANGLES		DR. PHIL		D / N ASG8HXX10	
. ± 0.4		Original Date		2015/01/06	
.X ± 0.3		CHK. JERRY		SCALE UNIT REV. SHEET	
.XX ± 0.15		APPD. STING		10:1 mm B 1/1	
.XXX ± 0.1		X°. ±5°		ATC ASSEM TECHNOLOGY CO., LTD.	
X.X° ±3°					

REV.	DCN/ECN	DESCRIPTION	DR.	DATE	APPD.

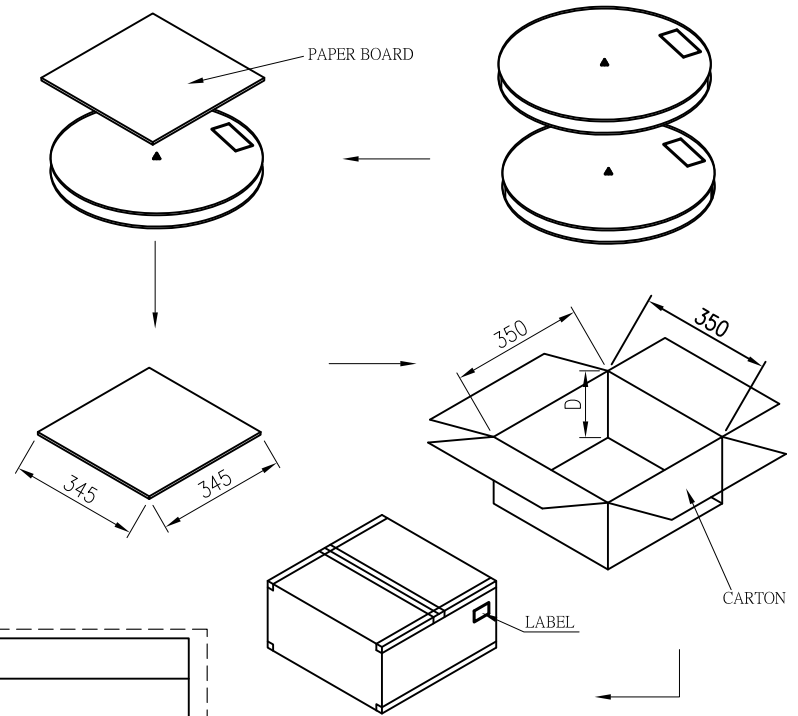
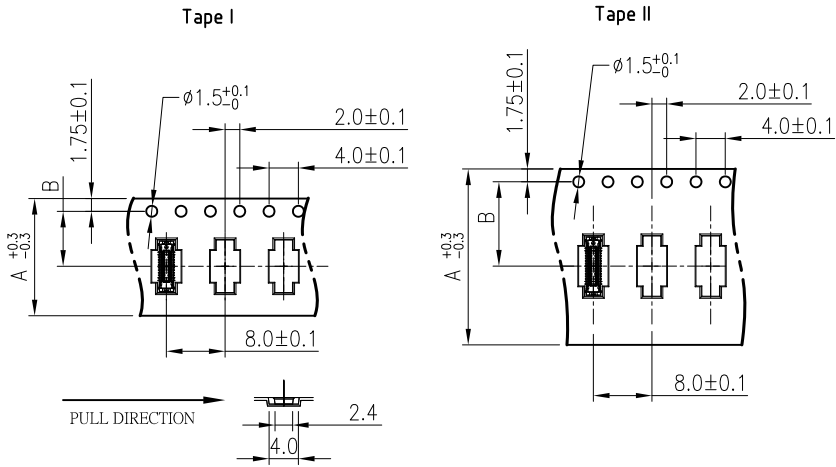

Reel package (EIAJ ET - 7200B) MATERIAL : PS

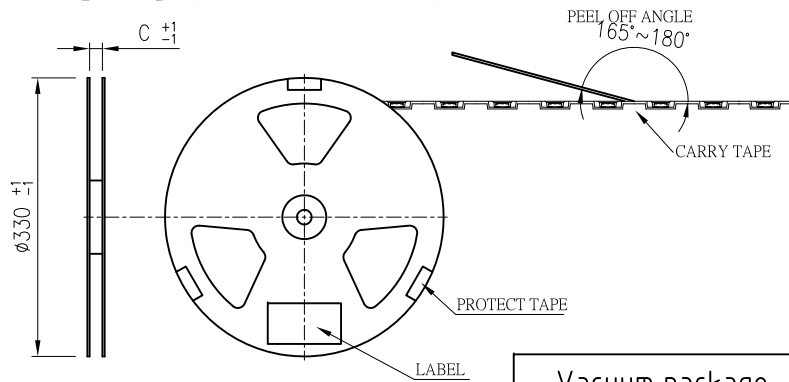

Vacuum package
 1. Vacuum the air out of the bag.
 2. Prevent the dust involve.

CARTON LABEL

Description	
Part No.	
Quantity	
N. W	
G. W	

REEL LABEL

Assem Technology Co., Ltd	
Description	
Part No.	
Quantity	
Date Code	

PIN	P / N	Type of Taping	DIM A	DIM B	DIM C	Reel	Reels	Carton	DIM D
60	ASGT54010	Tape II	24.0	11.5	25.4	5000 pcs	5	25000 pcs	180
50	ASGT55010								
44	ASGT54410								
40	ASGT54010								
34	ASGT53410								
30	ASGT53010	Tape I	16.0	7.5	17.4	5000 pcs	5	25000 pcs	145
24	ASGT52410								
20	ASGT52010								
16	ASGT51610								
12	ASGT51210								
10	ASGT51010								

Cover Tape MATERIAL : PET

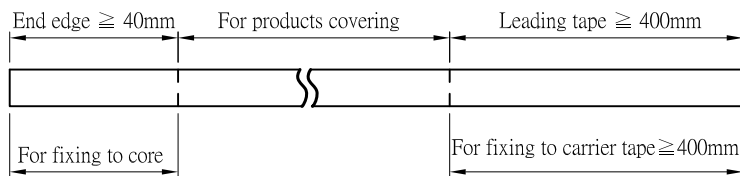

General tolerance		P/N		TITLE		0.35mm Pitch BOARD TO BOARD MATED HIGHT 0.60mm SOCKET CONNECTOR PACKING SPEC.	
DIMENSION	ANGLES	1C081-XX0XX-000		DR.		D/N	
.X ± 0.35	X° ± 5°	Original Date		PHIL		1C081-XX0XX-000	
.XX ± 0.25	X.X° ± 3°	2011/9/8		JERRY		REV. SHEET	
.XXX ± 0.15		SCALE		STING		1/1	
		1:1		UNIT		mm	
		REV.		A		ATC ASSEM TECHNOLOGY CO., LTD.	

REV.	DCN/ECN	DESCRIPTION	DR.	DATE	APPD.

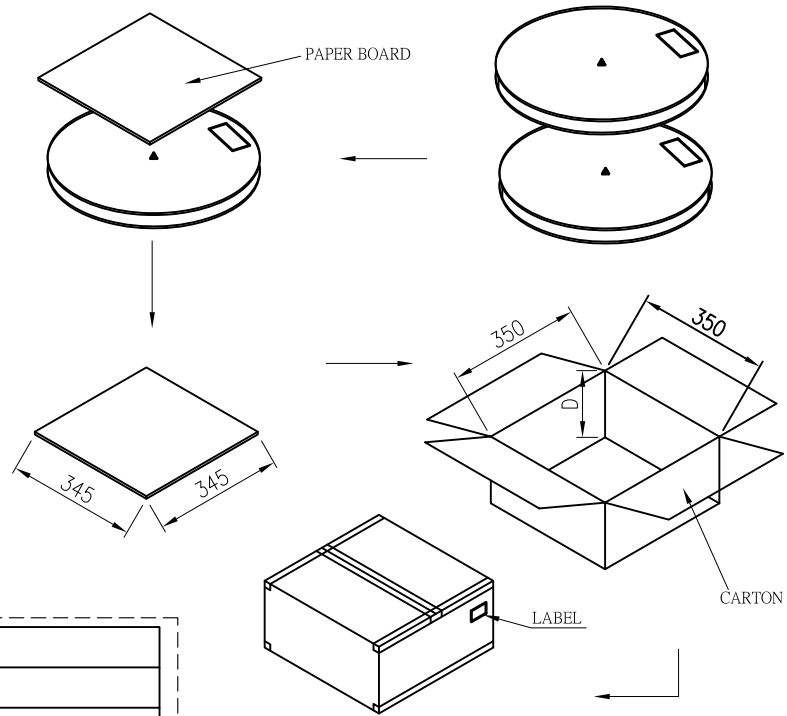
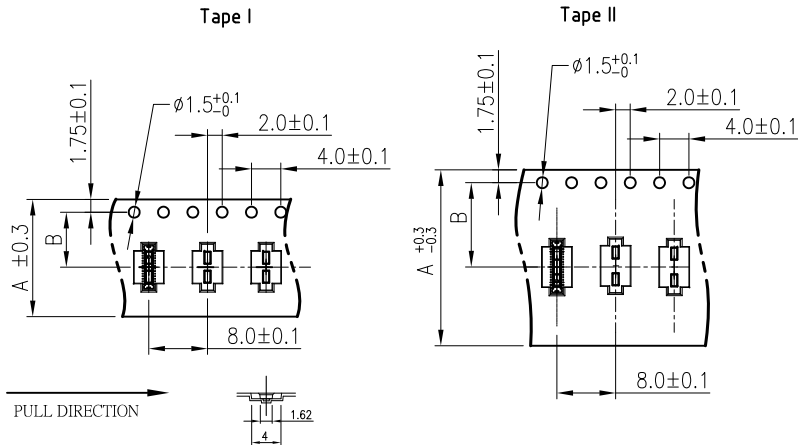

Reel package (EIAJ ET - 7200B) MATERIAL : PS

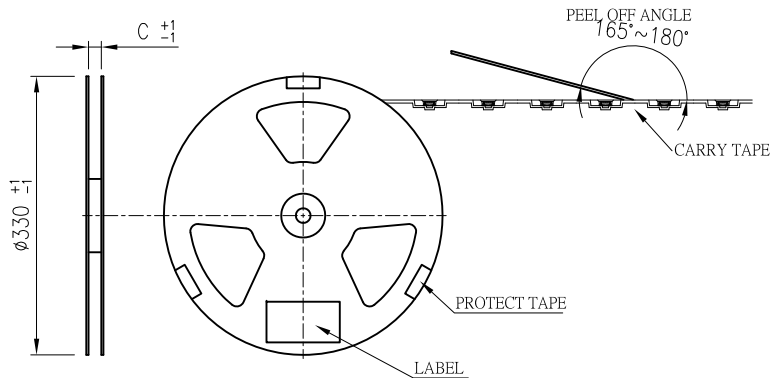

CARTON LABEL

Description	
Part No.	
Quantity	
N. W	
G. W	

REEL LABEL

Assem Technology Co., Ltd	
Description	
Part No.	
Quantity	
Date Code	

PIN	P / N	Type of Taping	DIM A	DIM B	DIM C	Reel	Reels	Carton	DIM D
60	ASGRH5010	Tape II	24.0	11.5	25.4	5000 pcs	5	25000 pcs	180
50	ASGRH5010								
44	ASGRH4110								
40	ASGRH4010								
34	ASGRH3410								
30	ASGRH3010	Tape I	16.0	7.5	17.4	5000 pcs	5	25000 pcs	145
24	ASGRH2410								
20	ASGRH2010								
16	ASGRH1610								
12	ASGRH1210								
10	ASGRH1010								

Vacuum package
 1. Vacuum the air out of the bag.
 2. Prevent the dust involve.

Cover Tape MATERIAL : PET

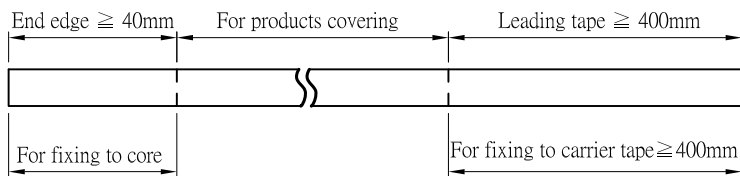

General tolerance		P/N		TITLE		0.35mm Pitch BOARD TO BOARD MATED HIGHT 0.60mm HEADER CONNECTOR PACKING SPEC.	
DIMENSION	ANGLES	1C082-XX0XX-000					
.X ± 0.35	X° ± 5°	DR.	PHIL	Original Date	2011/9/8	D/N	1C082-XX0XX-000
.XX ± 0.25	X.X° ± 3°	CHK.	JERRY	SCALE	UNIT	REV.	SHEET
.XXX ± 0.15		APPD.	STING	1:1	mm	A	1/1



TITLE: 0.4mm Pitch B TO B CONNECTOR

Date : 2012.01.10

REV

A

拔出方式:

平均施力平行拔出

Lift even, keeping both connectors parallel to each other.

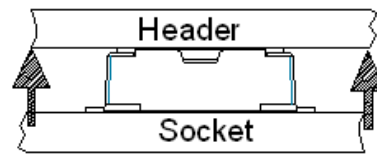
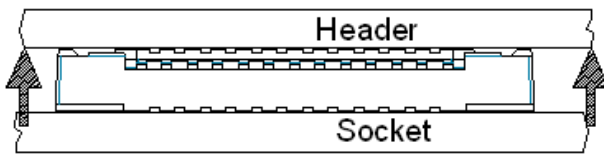

長邊方向避免單邊拔出，短邊方向可單邊拔出

Lift from short-side is acceptable. Do not attempt to lift the connectors from Long-side.

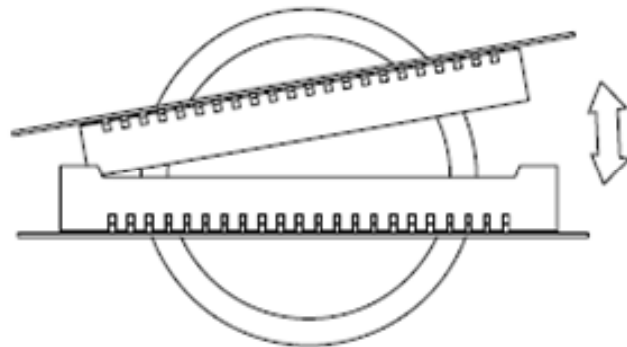
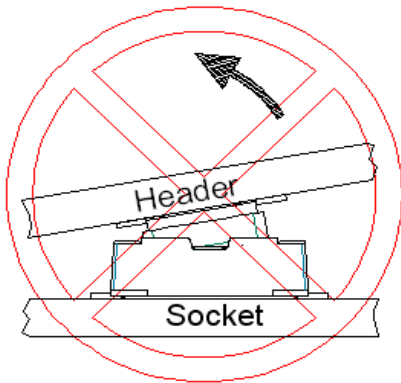

TITLE: 0.4mm Pitch B TO B CONNECTOR

Date : 2012.01.10

REV

A

避免以拉軟性電路板(FPC)方式分離

Do not attempt to un-mate the connectors by pulling the FPC.

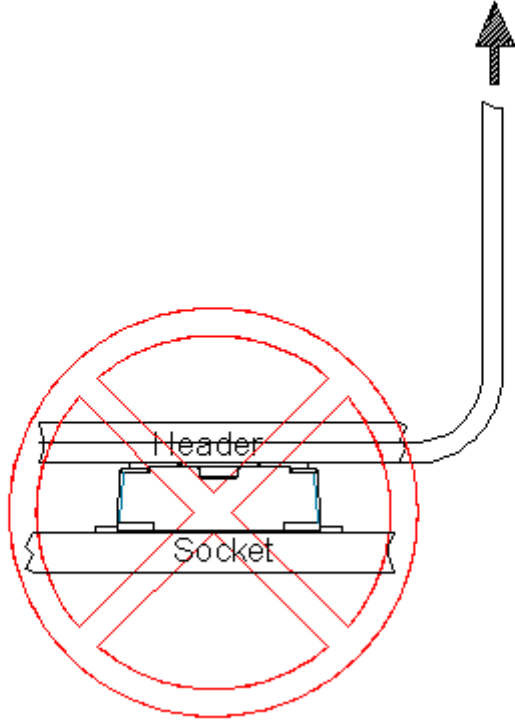

避免單一角落單獨施力

Do not attempt to start the un-mating of the connectors from one side or corner.

