

标记 MARK.	更改内容 MODIFICATION	日期 DATE	修改 DRAW	核准 APPROVE

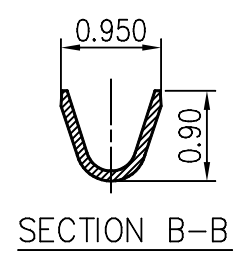
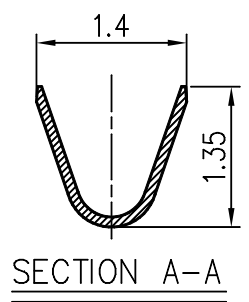
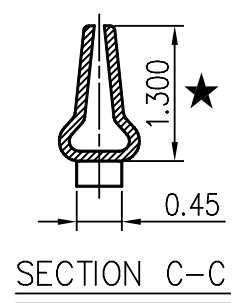
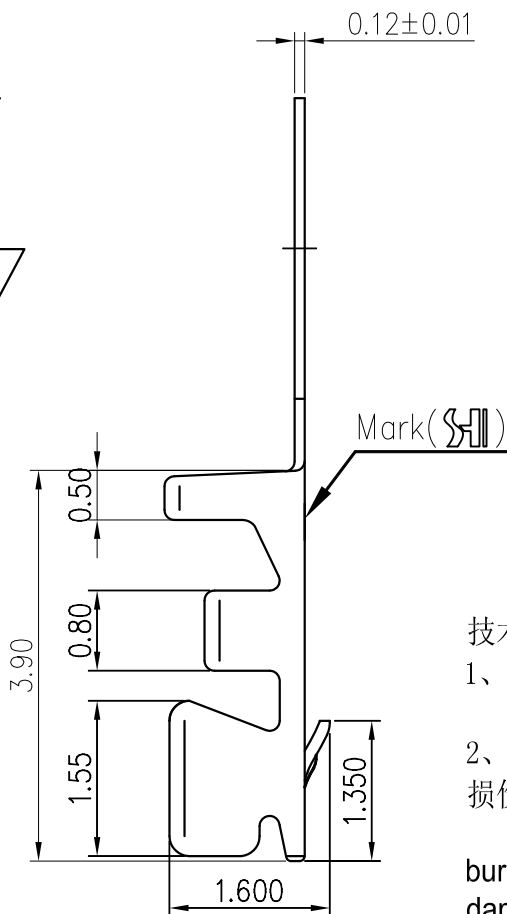
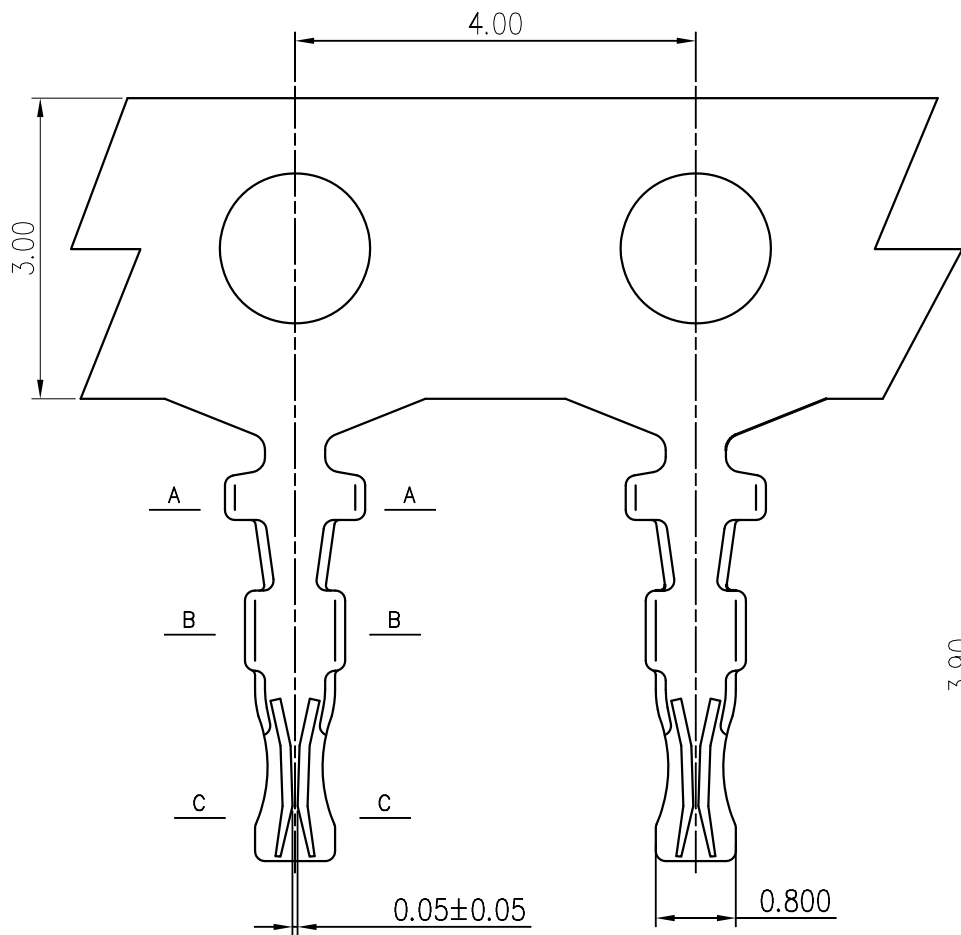

技术要求Specification:

- 1、材质：磷青铜，表面镀锡；
Material: Phos. Bronze Tin-Plated
- 2、零件外观不得有有害毛刺、尖角、锐边和机械损伤；表面镀层应均匀、光亮、无雾斑、剥层等缺陷；
Parts may not have the appearance of harmful burrs, sharp corners, sharp edges and mechanical damage, surface coating should be uniform, bright, no fog spots, delamination and other defects.
- 3、适用线号：AWG#32-#28；
Wirerange: AWG#32-#28;

TOLERANCE UNLESS OTHERWISE SPECIFIED		*: Inspection Item		兆星精密电子(深圳)有限公司			
.X±0.30	X.° ±1°	NO.	: Cp/Cpk and SPC Control Item	名称	SH1.0 端子		
.XX±0.2	.X° ±			料厚	0.12 mm	编号	ZX-SH1.0-DZ
.XXX±0.10	.XX° ±			材料	磷青铜	单位	mm
制图		料宽		比例	1:1	版本	A
审核		日期		角法	☉	规格书	
批准		日期		角法	☉	规格书	