

## **Description**

The WPE0581D3H is designed to protect voltage sensitive components from ESD and transient voltage events. Excellent clamping capability, low leakage, and fast response time, make these parts ideal for ESD protection on designs where board space is at a premium. This device has been specifically designed to protect sensitive components which are connected to data and transmission lines from overvoltage caused by ESD (electrostatic discharge), CDE (Cable Discharge Events), and EFT (electrical fast transients).

## **Features**

- 500W peak pulse power (8/20us)
- Protects one data or power line
- Low leakage: <math><1\mu A</math>
- Stand-off Voltage: 5 V
- Low clamping voltage
- Complies with following standards:
  - IEC 61000-4-2 (ESD) immunity test Air discharge:  $\pm 30kV$
  - Contact discharge:  $\pm 30kV$
- IEC61000-4-4 (EFT) 40A(5/50ns)
- IEC61000-4-5 (Lightning) 25A (8/20 $\mu s$ )
- RoHS Compliant

## **Dimensions & Symbol** (Unit: mm Max)

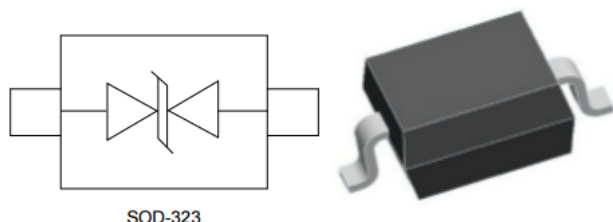

## **Mechanical Characteristics**

- Package: SOD-323
- Terminals: Tin plated, solderable per MIL-STD-750, method 2026
- Terminal Connections: See Diagram Below
- Marking Information: See Below

## **Applications**

- Cell Phone Handsets and Accessories
- Microprocessor based equipment
- Personal Digital Assistants (PDA's)
- Notebooks, Desktops, and Servers
- Portable Instrumentation
- Networking and Telecom
- Serial and Parallel Ports
- Peripherals

## **Marking information**



Details marking code reference customer approval list

## **Ordering Information**

Part Number	Packaging	Reel Size
WPE0581D3H	3000/Tape & Reel	7 inch

**Absolute Maximum Ratings (T<sub>A</sub>=25°C unless otherwise specified)**

Parameter	Symbol	Value	Unit
Peak Pulse Power (8/20µs)	Ppk	500	W
ESD per IEC 61000-4-2 (Air)	VESD	±30	kV
ESD per IEC 61000-4-2 (Contact)		±30	
Operating Temperature Range	T <sub>J</sub>	-40 to +150	°C
Storage Temperature Range	T <sub>stg</sub>	-40 to +150	°C

**Electrical Characteristics (T<sub>A</sub>=25°C unless otherwise specified)**

Parameter	Symbol	Min	Typ	Max	Unit	Test Condition
Reverse Working Voltage	V <sub>RWM</sub>			5	V	
Breakdown Voltage	V <sub>BR</sub>	5.8		7.8	V	I <sub>T</sub> = 1mA
Reverse Leakage Current	I <sub>R</sub>			1.0	uA	V <sub>RWM</sub> = 5V
Clamping Voltage	V <sub>C</sub>			9.8	V	I <sub>PP</sub> = 1A (8 x 20uS pulse)
Clamping Voltage	V <sub>C</sub>		18	20	V	I <sub>PP</sub> = 25A (8 x 20uS pulse)
Junction Capacitance	C <sub>J</sub>		35	45	pF	V <sub>R</sub> = 0V, f = 1MHz

**ELECTRICAL CHARACTERISTICS CURVE**

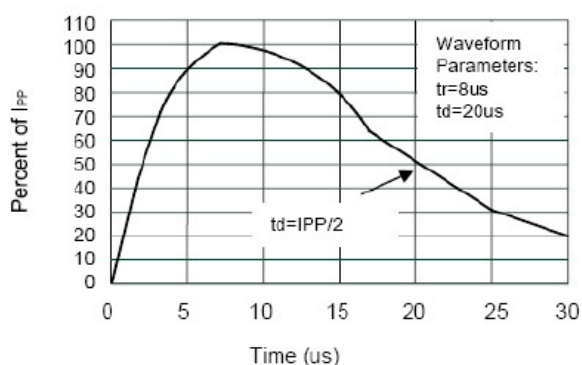

**Pulse Waveform**

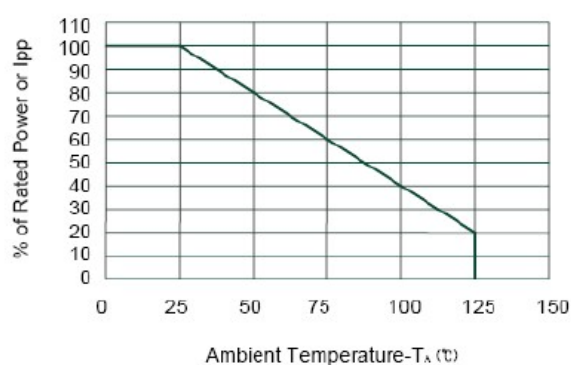

**Power Derating Curve**

## Soldering Parameters

Reflow Condition		Pb-Free assembly
Pre Heat	-Temperature Min ( $T_{s(min)}$ )	+150°C
	-Temperature Max( $T_{s(max)}$ )	+200°C
	-Time (Min to Max) (ts)	60-180 secs.
Average ramp up rate (Liquid us Temp ( $T_L$ ) to peak)		3°C/sec. Max
$T_{s(max)}$ to $T_L$ - Ramp-up Rate		3°C/sec. Max
Reflow	-Temperature( $T_L$ ) (Liquid us)	+217°C
	-Temperature( $t_L$ )	60-150 secs.
Peak Temp ( $T_p$ )		+260(+0/-5)°C
Time within 5°C of actual Peak Temp ( $t_p$ )		30 secs. Max
Ramp-down Rate		6°C/sec. Max
Time 25°C to Peak Temp ( $T_P$ )		8 min. Max
Do not exceed		+260°C

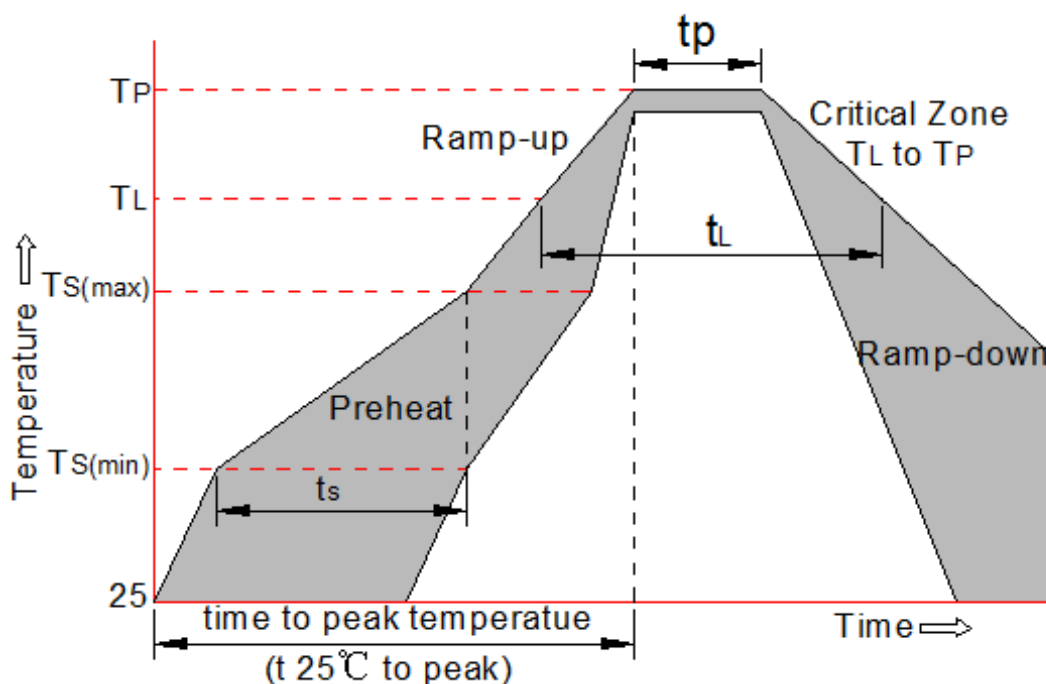

## Package Mechanical Data

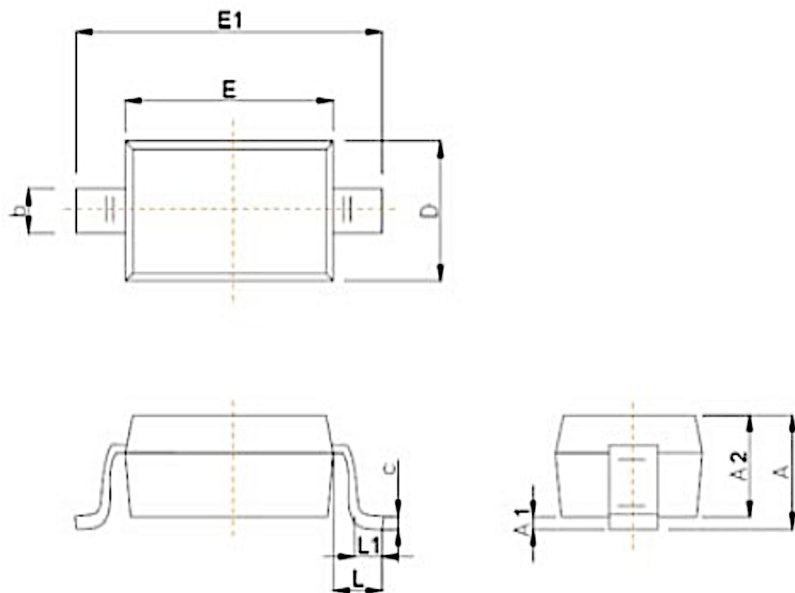

Symbol	Dimensions (mm)	
	Min	Max
A		1.00
A1	0.000	0.100
A2	0.800	0.900
b	0.250	0.350
c	0.080	0.150
D	1.200	1.400
E	1.600	1.800
E1	2.500	2.700
e	1.800	2.040
L	0.475 Ref	
L1	0.250	0.400
$\theta$	0	8°

## Suggested Land Pattern

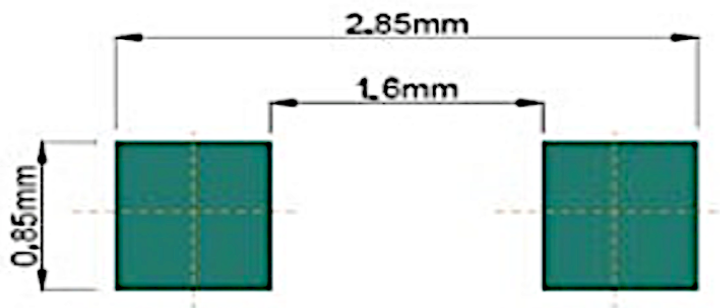

## Contact Information

WPMTEK Incorporated Limited  
 Room 207,2nd Floor, Block 3,Minxing Industry Park, Minzhi,  
 Longhua New District, Shenzhen, PRC.  
 TEL: 86755-29308003      FAX: 86755-23739900

Wpmtek Incorporated Limited (WPM) reserves the right to make changes to the product specification and data in this document without notice. WPM makes no warranty, representation or guarantee regarding the suitability of its products for any particular purpose, nor does WPM assume any liability arising from the application or use of any products or circuits, and specifically dis- claims any and all liability, including without limitation special, consequential or incidental damages.